

NEC

Preliminary User's Manual

μ PD780973 Subseries

8-Bit Single-Chip Microcontrollers

μ PD780973(A)

μ PD78F0974

Document No. U12406EJ2V0UM00 (2nd edition)
Date Published May 1998 N CP(K)

© NEC Corporation 1997
Printed in Japan

[MEMO]

NOTES FOR CMOS DEVICES

① PRECAUTION AGAINST ESD FOR SEMICONDUCTORS

Note:

Strong electric field, when exposed to a MOS device, can cause destruction of the gate oxide and ultimately degrade the device operation. Steps must be taken to stop generation of static electricity as much as possible, and quickly dissipate it once, when it has occurred. Environmental control must be adequate. When it is dry, humidifier should be used. It is recommended to avoid using insulators that easily build static electricity. Semiconductor devices must be stored and transported in an anti-static container, static shielding bag or conductive material. All test and measurement tools including work bench and floor should be grounded. The operator should be grounded using wrist strap. Semiconductor devices must not be touched with bare hands. Similar precautions need to be taken for PW boards with semiconductor devices on it.

② HANDLING OF UNUSED INPUT PINS FOR CMOS

Note:

No connection for CMOS device inputs can be cause of malfunction. If no connection is provided to the input pins, it is possible that an internal input level may be generated due to noise, etc., hence causing malfunction. CMOS devices behave differently than Bipolar or NMOS devices. Input levels of CMOS devices must be fixed high or low by using a pull-up or pull-down circuitry. Each unused pin should be connected to V_{DD} or GND with a resistor, if it is considered to have a possibility of being an output pin. All handling related to the unused pins must be judged device by device and related specifications governing the devices.

③ STATUS BEFORE INITIALIZATION OF MOS DEVICES

Note:

Power-on does not necessarily define initial status of MOS device. Production process of MOS does not define the initial operation status of the device. Immediately after the power source is turned ON, the devices with reset function have not yet been initialized. Hence, power-on does not guarantee out-pin levels, I/O settings or contents of registers. Device is not initialized until the reset signal is received. Reset operation must be executed immediately after power-on for devices having reset function.

EEPROM, FIP, and IEBus are trademarks of NEC Corporation.

Windows and WindowsNT are either registered trademarks or trademarks of Microsoft Corporation in the United States and/or other countries.

PC/AT is a trademark of International Business Machines Corporation.

HP9000 series 700 and HP-UX are trademarks of Hewlett-Packard Company.

SPARCstation is a trademark of SPARC International, Inc.

SunOS is a trademark of Sun Microsystems, Inc.

Ethernet is a trademark of Xerox Corporation.

NEWS and NEWS-OS are trademarks of Sony Corporation.

OSF/Motif is a trademark of OpenSoftware Foundation, Inc.

TRON is an abbreviation of The Realtime Operating system Nucleus.

ITRON is an abbreviation of Industrial TRON.

The export of these products from Japan is regulated by the Japanese government. The export of some or all of these products may be prohibited without governmental license. To export or re-export some or all of these products from a country other than Japan may also be prohibited without a license from that country. Please call an NEC sales representative.

License not needed : μ PD78F0974GF-3B9
The customer must judge the need for license : μ PD780973GF(A)-xxx-3B9

The application circuits and their parameters are for reference only and are not intended for use in actual design-ins.

This product is produced and sold based on the licensed agreement with CP8 Transac concerning EEPROM-contained microcontroller.

This product cannot be used for an IC card (SMART CARD).

The information in this document is subject to change without notice.

No part of this document may be copied or reproduced in any form or by any means without the prior written consent of NEC Corporation. NEC Corporation assumes no responsibility for any errors which may appear in this document.

NEC Corporation does not assume any liability for infringement of patents, copyrights or other intellectual property rights of third parties by or arising from use of a device described herein or any other liability arising from use of such device. No license, either express, implied or otherwise, is granted under any patents, copyrights or other intellectual property rights of NEC Corporation or others.

While NEC Corporation has been making continuous effort to enhance the reliability of its semiconductor devices, the possibility of defects cannot be eliminated entirely. To minimize risks of damage or injury to persons or property arising from a defect in an NEC semiconductor device, customers must incorporate sufficient safety measures in its design, such as redundancy, fire-containment, and anti-failure features.

NEC devices are classified into the following three quality grades:

"Standard", "Special", and "Specific". The Specific quality grade applies only to devices developed based on a customer designated "quality assurance program" for a specific application. The recommended applications of a device depend on its quality grade, as indicated below. Customers must check the quality grade of each device before using it in a particular application.

Standard: Computers, office equipment, communications equipment, test and measurement equipment, audio and visual equipment, home electronic appliances, machine tools, personal electronic equipment and industrial robots

Special: Transportation equipment (automobiles, trains, ships, etc.), traffic control systems, anti-disaster systems, anti-crime systems, safety equipment and medical equipment (not specifically designed for life support)

Specific: Aircrafts, aerospace equipment, submersible repeaters, nuclear reactor control systems, life support systems or medical equipment for life support, etc.

The quality grade of NEC devices is "Standard" unless otherwise specified in NEC's Data Sheets or Data Books. If customers intend to use NEC devices for applications other than those specified for Standard quality grade, they should contact an NEC sales representative in advance.

Anti-radioactive design is not implemented in this product.

Regional Information

Some information contained in this document may vary from country to country. Before using any NEC product in your application, please contact the NEC office in your country to obtain a list of authorized representatives and distributors. They will verify:

- Device availability
- Ordering information
- Product release schedule
- Availability of related technical literature
- Development environment specifications (for example, specifications for third-party tools and components, host computers, power plugs, AC supply voltages, and so forth)
- Network requirements

In addition, trademarks, registered trademarks, export restrictions, and other legal issues may also vary from country to country.

NEC Electronics Inc. (U.S.)

Santa Clara, California
Tel: 408-588-6000
800-366-9782
Fax: 408-588-6130
800-729-9288

NEC Electronics (Germany) GmbH

Duesseldorf, Germany
Tel: 0211-65 03 02
Fax: 0211-65 03 490

NEC Electronics (UK) Ltd.

Milton Keynes, UK
Tel: 01908-691-133
Fax: 01908-670-290

NEC Electronics Italiana s.r.l.

Milano, Italy
Tel: 02-66 75 41
Fax: 02-66 75 42 99

NEC Electronics (Germany) GmbH

Benelux Office
Eindhoven, The Netherlands
Tel: 040-2445845
Fax: 040-2444580

NEC Electronics (France) S.A.

Velizy-Villacoublay, France
Tel: 01-30-67 58 00
Fax: 01-30-67 58 99

NEC Electronics (France) S.A.

Spain Office
Madrid, Spain
Tel: 01-504-2787
Fax: 01-504-2860

NEC Electronics (Germany) GmbH

Scandinavia Office
Taebby, Sweden
Tel: 08-63 80 820
Fax: 08-63 80 388

NEC Electronics Hong Kong Ltd.

Hong Kong
Tel: 2886-9318
Fax: 2886-9022/9044

NEC Electronics Hong Kong Ltd.

Seoul Branch
Seoul, Korea
Tel: 02-528-0303
Fax: 02-528-4411

NEC Electronics Singapore Pte. Ltd.

United Square, Singapore 1130
Tel: 65-253-8311
Fax: 65-250-3583

NEC Electronics Taiwan Ltd.

Taipei, Taiwan
Tel: 02-719-2377
Fax: 02-719-5951

NEC do Brasil S.A.

Cumbica-Guarulhos-SP, Brasil
Tel: 011-6465-6810
Fax: 011-6465-6829

MAJOR REVISIONS IN THIS EDITION (1/2)

Page	Description
p.38	Table 2-1. Pin Input/Output Circuit Types Correction of ports 8 and 9 input/output circuit types
p.40	Figure 2-1. I/O Circuits of Pins Change of type 17-A to type 17-G
p.54	Addition of oscillator mode register to Table 3-5. Special Function Register List
p.67	4.1 EEPROM Functions Change of the number of rewrite frequency per 1 byte as follows: 10,000 times → 100,000 times
p.77	5.2.3 Port 2 <ul style="list-style-type: none"> • Correction of description • Correction of Figure 5-4. P20 to P27 Block Diagram
p.78	5.2.4 Port 3 <ul style="list-style-type: none"> • Correction of description • Correction of Figure 5-5. P30 to P37 Block Diagram
p.82	5.2.8 Port 8 <ul style="list-style-type: none"> • Correction of description • Addition of Figure 5-9. P81 Block Diagram • Correction of Figure 5-10. P82 to P87 Block Diagram
p.83	5.2.9 Port 9 <ul style="list-style-type: none"> • Correction of description • Correction of Figure 5-11. P90 to P97 Block Diagram
p.85	Table 5-3. Port Mode Register and Output Latch Settings when Using Alternate Functions <ul style="list-style-type: none"> • Change of P_{xx} setting values of P20 to P27 and P30 to P37 from 0 to x • Change of Note 2
p.86	Addition of Note in Figure 5-13. Port Mode Register (PM2, PM3) Format
p.89	CHAPTER 6 CLOCK GENERATOR <ul style="list-style-type: none"> • Addition of oscillator mode register to Table 6-1. Clock Generator Configuration • Change of Figure 6-1. Clock Generator Block Diagram • Addition of (2) Oscillator mode register (OSCM) to 6.3 Clock Generator Control Register • Addition of explanation of oscillator mode register to 6.5 Operation of Clock Generator
p.163	13.6 Cautions on Emulation Change of in-circuit emulator of (1) D/A converter mode register (DAM1) as follows: IE-78001-R-A → IE78K0-NS Addition of (2) A/D converter of IE-780974-NS-EM1
p.203	16.9 Cautions on Emulation Change of in-circuit emulator of (1) LCD timer control register (LCDTM) as follows: IE-78001-R-A → IE78K0-NS
p.205	17.1 Sound Generator Function Correction of description on (1) Basic cycle output signal (with/without amplitude)
p.214	18.2 Meter Controller/Driver Configuration Addition of Cautions to (1) Free running up counter (MCNT)
p.247	Table 20-1. HALT Mode Operating Status Correction of HALT mode operating status of A/D converter Operable → Operation stops

The mark ★ shows major revised points.

MAJOR REVISIONS IN THIS EDITION (2/2)

Page	Description
p.255	Addition of oscillator mode register to Table 21-1. Hardware Status after Reset
p.257	Change of Note in Table 22-1. Differences between μPD78F0974 and μPD780973(A)
p.279	APPENDIX A DEVELOPMENT TOOLS <ul style="list-style-type: none"> • Support of in-circuit emulator IE-78K0-NS • Change in supported OS • Addition of A.4 Upgrading Former In-circuit Emulator for 78K/0 Series to IE-78001-R-A • Deletion of OS for IBM PC from previous edition • Deletion of Development Environment when Using IE-78000-R-A from previous edition
p.291	APPENDIX B EMBEDDED SOFTWARE <ul style="list-style-type: none"> • Change in supported OS • Deletion of Fuzzy Inference Development Support System from previous edition

The mark ★ shows major revised points.

INTRODUCTION

Readers This manual has been prepared for user engineers who want to understand the functions of the μ PD780973 Subseries and design and develop its application systems and programs.

Purpose This manual is designed to help users understand the following functions using the organization below.

Organization The μ PD780973 Subseries manual is separated into two parts: this manual and the instruction edition (common to the 78K/0 Series).



- | | |
|---|---|
| <ul style="list-style-type: none">• Pin functions• Internal block functions• Interrupt• Other on-chip peripheral functions | <ul style="list-style-type: none">• CPU functions• Instruction set• Explanation of each instruction |
|---|---|

How to Read This Manual This manual assumes general knowledge of electric engineering, logic circuits, and microcontrollers.

- To understand the functions of the μ PD780973(A) and 78F0974 in general:
→ Read this manual in the order of the **CONTENTS**.
- How to read register formats:
→ The name of a bit whose number is enclosed in square is reserved for the RA78K/0 and is defined for the CC78K/0 by the header file sfrbit.h.
- To learn the detailed functions of a register whose register name is known:
→ Refer to **APPENDIX C REGISTER INDEX**.

The application examples in this manual are for the "standard" model for general-purpose electronic systems. If the examples in this manual are to be used for applications where a quality higher than that of the "special" model is required, study the quality grade of the respective components and circuits actually used.

Conventions

Data significance	:	Higher digits on the left and lower digits on the right
Active low representation	:	$\overline{\text{xxx}}$ (overscore over pin or signal name)
Note	:	Footnote for item marked with Note in the text
Caution	:	Information requiring particular attention
Remark	:	Supplementary information
Numerical representation	:	Binary ... xxxx or xxxxB
		Decimal ... xxxx
		Hexadecimal ... xxxxH

Related Documents The related documents indicated in this publication may include preliminary versions. However, preliminary versions are not marked as such.

• **Related documents for μ PD780973 Subseries**

Document Name	Document No.	
	Japanese	English
μ PD780973(A) Preliminary Product Information	U12759J	U12759E
μ PD78F0974 Preliminary Product Information	U12646J	U12646E
μ PD780973 Subseries User's Manual	U12406J	This manual
78K/0 Series User's Manual Instructions	U12326J	U12326E
78K/0 Series Instruction Table	U10903J	—
78K/0 Series Instruction Set	U10904J	—
μ PD780973 Subseries Special Function Register Table	U12748J	—

• **Related documents for development tool (User's Manual)**

Document Name		Document No.	
		Japanese	English
RA78K0 Assembler Package	Operation	U11802J	U11802E
	Assembly Language	U11801J	U11801E
	Structured Assembly Language	U11789J	U11789E
RA78K Series Structured Assembler Preprocessor		EEU-817	EEU-1402
CC78K0 C Compiler	Operation	U11517J	U11517E
	Language	U11518J	U11518E
CC78K/0 C Compiler Application Note	Programming Know-how	U13034J	EEA-1208
CC78K Series Library Source File		U12322J	—
IE-78K0-NS		To be prepared	To be prepared
IE-78001-R-A		To be prepared	To be prepared
SM78K0 System Simulator Windows™ Base	Reference	U10181J	U10181E
SM78K Series System Simulator	External Part User Open Interface Specifications	U10092J	U10092E
ID78K0-NS Integrated Debugger PC Base	Reference	U12900J	To be prepared
ID78K0 Integrated Debugger EWS Base	Reference	U11151J	—
ID78K0 Integrated Debugger PC Base	Reference	U11539J	U11539E
ID78K0 Integrated Debugger Windows Base	Guide	U11649J	U11649E

Caution The above documents are subject to change without prior notice. Be sure to use the latest version of a document when starting design.

- **Related documents for embedded software (User's Manual)**

Document Name		Document No.	
		Japanese	English
78K/0 Series Real-Time OS	Basics	U11537J	U11537E
	Installation	U11536J	U11536E
78K/0 Series OS MX78K0	Basics	U12257J	U12257E

- **Other related documents**

Document Name		Document No.	
		Japanese	English
IC Package Manual		C10943X	
Semiconductor Device Mounting Technology Manual		C10535J	C10535E
Quality Grades on NEC Semiconductor Devices		C11531J	C11531E
NEC Semiconductor Device Reliability/Quality Control System		C10983J	C10983E
Guide to Prevent Damage for Semiconductor Devices by Electro Static Discharge (ESD)		C11892J	C11892E
Guide to Quality Assurance for Semiconductor Devices		—	MEI-1202
Microcomputer Product Series Guide		U11416J	—

Caution The above documents are subject to change without prior notice. Be sure to use the latest version of a document when starting design.

CONTENTS

CHAPTER 1 OUTLINE	23
1.1 Features	23
1.2 Applications	23
1.3 Ordering Information	24
1.4 Quality Grade	24
1.5 Pin Configuration (Top View)	25
1.6 78K/0 Series Product Development	27
1.7 Block Diagram	29
1.8 Outline of Function	30
CHAPTER 2 PIN FUNCTION.....	31
2.1 Pin Function List	31
2.2 Description of Pin Functions	33
2.2.1 P00 to P07 (Port 0)	33
2.2.2 P10 to P14 (Port 1)	33
2.2.3 P20 to P27 (Port 2)	33
2.2.4 P30 to P37 (Port 3)	34
2.2.5 P40 to P44 (Port 4)	34
2.2.6 P50 to P54 (Port 5)	34
2.2.7 P60, P61 (Port 6)	35
2.2.8 P81 to P87 (Port 8)	35
2.2.9 P90 to P97 (Port 9)	36
2.2.10 COM0 to COM3	36
2.2.11 V _{LCD}	36
2.2.12 AV _{REF}	36
2.2.13 AV _{SS}	36
2.2.14 $\overline{\text{RESET}}$	36
2.2.15 X1 and X2	36
2.2.16 SMV _{DD}	36
2.2.17 SMV _{SS}	36
2.2.18 V _{DD}	36
2.2.19 V _{SS}	36
2.2.20 V _{PP} (μ PD78F0974)	37
2.2.21 IC (μ PD780973(A))	37
2.3 Input/output Circuits and Recommended Connection of Unused Pins	38
CHAPTER 3 CPU ARCHITECTURE	41
3.1 Memory Spaces	41
3.1.1 Internal program memory space	43
3.1.2 Internal data memory space	44
3.1.3 Special function register (SFR) area	44
3.1.4 Data memory addressing	45
3.2 Processor Registers	47
3.2.1 Control registers	47
3.2.2 General registers	50

3.2.3	Special function registers (SFRs)	51
3.3	Instruction Address Addressing	55
3.3.1	Relative addressing	55
3.3.2	Immediate addressing	56
3.3.3	Table indirect addressing	57
3.3.4	Register addressing	57
3.4	Operand Address Addressing	58
3.4.1	Implied addressing	58
3.4.2	Register addressing	59
3.4.3	Direct addressing	60
3.4.4	Short direct addressing	61
3.4.5	Special-function register (SFR) addressing	62
3.4.6	Register indirect addressing	63
3.4.7	Based addressing	64
3.4.8	Based indexed addressing	64
3.4.9	Stack addressing	65
CHAPTER 4	EEPROM	67
4.1	EEPROM Functions	67
4.2	EEPROM Configuration	68
4.3	EEPROM Control Register	69
4.4	EEPROM Reading	70
4.5	EEPROM Writing	71
4.6	EEPROM Control-Related Interrupt	71
4.7	Cautions regarding EEPROM Writing	72
CHAPTER 5	PORT FUNCTIONS	73
5.1	Port Functions	73
5.2	Port Configuration	75
5.2.1	Port 0	75
5.2.2	Port 1	76
5.2.3	Port 2	77
5.2.4	Port 3	78
5.2.5	Port 4	79
5.2.6	Port 5	80
5.2.7	Port 6	81
5.2.8	Port 8	82
5.2.9	Port 9	83
5.3	Port Function Control Registers	84
5.4	Port Function Operations	88
5.4.1	Writing to input/output port	88
5.4.2	Reading from input/output port	88
5.4.3	Operations on input/output port	88
CHAPTER 6	CLOCK GENERATOR	89
6.1	Clock Generator Functions	89
6.2	Clock Generator Configuration	89
6.3	Clock Generator Control Register	90

6.4	System Clock Oscillator	92
6.4.1	Main system clock oscillator	92
6.4.2	Divider circuit	94
6.5	Operation of Clock Generator	95
6.6	Changing Setting of CPU Clock	96
6.6.1	Time required for switching CPU clock	96
6.6.2	Switching CPU clock	97
CHAPTER 7	16-BIT TIMER 0 TM0	99
7.1	Outline of Internal Timer of μPD780973 Subseries	99
7.2	16-Bit Timer 0 Functions	100
7.3	16-Bit Timer 0 Configuration	102
7.4	16-Bit Timer 0 Control Registers	103
7.5	16-Bit Timer 0 Operations	106
7.5.1	Pulse width measurement operations	106
7.6	16-Bit Timer 0 Cautions	109
CHAPTER 8	8-BIT TIMER 1 TM1	111
8.1	8-Bit Timer 1 Functions	111
8.2	8-Bit Timer 1 Configuration	112
8.3	8-Bit Timer 1 Control Registers	113
8.4	8-Bit Timer 1 Operations	115
8.4.1	8-bit interval timer operation	115
8.5	8-Bit Timer 1 Cautions	118
CHAPTER 9	8-BIT TIMER/EVENT COUNTERS 2, 3 TM2, TM3	119
9.1	8-Bit Timer/Event Counters 2 and 3 Functions	119
9.2	8-Bit Timer/Event Counters 2 and 3 Configurations	121
9.3	8-Bit Timer/Event Counters 2 and 3 Control Registers	122
9.4	8-Bit Timer/Event Counters 2 and 3 Operations	125
9.4.1	8-bit interval timer operation	125
9.4.2	External event counter operation	127
9.4.3	Square-wave output operation (8-bit resolution)	128
9.4.4	8-bit PWM output operation	129
9.5	8-Bit Timer/Event Counters 2 and 3 Cautions	132
CHAPTER 10	WATCH TIMER	133
10.1	Watch Timer Functions	133
10.2	Watch Timer Configuration	134
10.3	Watch Timer Control Register	135
10.4	Watch Timer Operations	136
10.4.1	Watch timer operation	136
10.4.2	Interval timer operation	136
CHAPTER 11	WATCHDOG TIMER	139
11.1	Watchdog Timer Functions	139
11.2	Watchdog Timer Configuration	141
11.3	Watchdog Timer Control Registers	141

11.4 Watchdog Timer Operations	143
11.4.1 Watchdog timer operation	143
11.4.2 Interval timer operation	144
CHAPTER 12 CLOCK OUTPUT CONTROL CIRCUIT	145
12.1 Clock Output Control Circuit Functions	145
12.2 Clock Output Control Circuit Configuration	145
12.3 Clock Output Control Circuit Control Registers	146
12.4 Clock Output Control Circuit Operation	148
12.4.1 Clock output operation	148
CHAPTER 13 A/D CONVERTER	149
13.1 A/D Converter Functions	149
13.2 A/D Converter Configuration	150
13.3 A/D Converter Control Registers	152
13.4 A/D Converter Operations	155
13.4.1 Basic operations of A/D converter	155
13.4.2 Input voltage and conversion results	157
13.4.3 A/D converter operation mode	158
13.5 A/D Converter Cautions	160
13.6 Cautions on Emulation	163
CHAPTER 14 SERIAL INTERFACE UART	165
14.1 UART Functions	165
14.2 UART Configuration	166
14.3 UART Control Registers	167
14.4 UART Operations	171
14.4.1 Operation stop mode	171
14.4.2 Asynchronous serial interface (UART) mode	171
CHAPTER 15 SERIAL INTERFACE SIO3	183
15.1 SIO3 Functions	183
15.2 SIO3 Configuration	184
15.3 SIO3 Control Register	185
15.4 SIO3 Operations	186
15.4.1 Operation stop mode	186
15.4.2 Three-wire serial I/O mode	187
CHAPTER 16 LCD CONTROLLER/DRIVER	189
16.1 LCD Controller/Driver Functions	189
16.2 LCD Controller/Driver Configuration	190
16.3 LCD Controller/Driver Control Registers	192
16.4 LCD Controller/Driver Settings	194
16.5 LCD Display Data Memory	195
16.6 Common Signals and Segment Signals	196
16.7 Supplying LCD Drive Voltage V_{LC0}, V_{LC1}, and V_{LC2}	198
16.8 Display Mode	200
16.8.1 4-time-division display example	200

16.9 Cautions on Emulation	203
CHAPTER 17 SOUND GENERATOR	205
17.1 Sound Generator Function	205
17.2 Sound Generator Configuration	206
17.3 Sound Generator Control Registers	207
17.4 Sound Generator Operations	212
17.4.1 To output basic cycle signal SGOF (without amplitude)	212
17.4.2 To output basic cycle signal SGO (with amplitude)	212
CHAPTER 18 METER CONTROLLER/DRIVER	213
18.1 Meter Controller/Driver Functions	213
18.2 Meter Controller/Driver Configuration	214
18.3 Meter Controller/Driver Control Registers	216
18.4 Meter Controller/Driver Operations	220
18.4.1 Basic operation of free-running up counter (MCNT)	220
18.4.2 To update PWM data	220
18.4.3 Operation of 1-bit addition circuit	221
18.4.4 PWM output operation (output with 1 clock shifted)	222
CHAPTER 19 INTERRUPT FUNCTIONS	223
19.1 Interrupt Function Types	223
19.2 Interrupt Sources and Configuration	223
19.3 Interrupt Function Control Registers	227
19.4 Interrupt Servicing Operations	234
19.4.1 Non-maskable interrupt request acknowledge operation	234
19.4.2 Maskable interrupt request acknowledge operation	237
19.4.3 Software interrupt request acknowledge operation	239
19.4.4 Multiple interrupt servicing	240
19.4.5 Interrupt request hold	243
CHAPTER 20 STANDBY FUNCTION	245
20.1 Standby Function and Configuration	245
20.1.1 Standby function	245
20.1.2 Standby function control register	246
20.2 Standby Function Operations	247
20.2.1 HALT mode	247
20.2.2 STOP mode	250
CHAPTER 21 RESET FUNCTION	253
21.1 Reset Function	253
CHAPTER 22 μPD78F0974	257
22.1 Memory Size Switching Register	258
22.2 Flash Memory Programming	259
22.2.1 Selection of transmission method	259
22.2.2 Flash memory programming function	260
22.2.3 Flashpro II connection	260

CHAPTER 23 INSTRUCTION SET	263
23.1 Legend for Operation List	264
23.1.1 Operand identifiers and description formats	264
23.1.2 Description of "operation" column	265
23.1.3 Description of "flag operation" column	265
23.2 Operation List	266
23.3 Instructions Listed by Addressing Type	274
APPENDIX A DEVELOPMENT TOOLS	279
A.1 Language Processing Software	282
A.2 Flash Memory Writing Tools	283
A.3 Debugging Tools	284
A.3.1 Hardware	284
A.3.2 Software	286
A.4 Upgrading Former In-circuit Emulator for 78K/0 Series to IE-78001-R-A	288
APPENDIX B EMBEDDED SOFTWARE	291
APPENDIX C REGISTER INDEX	293
C.1 Register Index (In Alphabetical Order with Respect to Register Name)	293
C.2 Register Index (In Alphabetical Order with Respect to Register Symbol)	296
APPENDIX D REVISION HISTORY	299

LIST OF FIGURES (1/4)

Figure No.	Title	Page
2-1.	I/O Circuits of Pins	39
3-1.	Memory Map (μ PD780973(A))	41
3-2.	Memory Map (μ PD78F0974)	42
3-3.	Data Memory Addressing (μ PD780973(A))	45
3-4.	Data Memory Addressing (μ PD78F0974)	46
3-5.	Program Counter Configuration	47
3-6.	Program Status Word Configuration	47
3-7.	Stack Pointer Configuration	49
3-8.	Data to be Saved to Stack Memory	49
3-9.	Data to be Reset from Stack Memory	49
3-10.	General Register Configuration	50
4-1.	EEPROM Block Diagram	68
4-2.	EEPROM Write Control Register (EEWC) Format	69
5-1.	Port Types	73
5-2.	P00 to P07 Block Diagram	76
5-3.	P10 to P14 Block Diagram	76
5-4.	P20 to P27 Block Diagram	77
5-5.	P30 to P37 Block Diagram	78
5-6.	P40 to P44 Block Diagram	79
5-7.	P50 to P54 Block Diagram	80
5-8.	P60 and P61 Block Diagram	81
5-9.	P81 Block Diagram	82
5-10.	P82 to P87 Block Diagram	82
5-11.	P90 to P97 Block Diagram	83
5-12.	Port Mode Register (PM0, PM4 to PM6, PM8, PM9) Format	86
5-13.	Port Mode Register (PM2, PM3) Format	86
5-14.	Pull-Up Resistor Option Register (PU0) Format	87
6-1.	Clock Generator Block Diagram	89
6-2.	Processor Clock Control Register (PCC) Format	90
6-3.	Oscillator Mode Register (OSCM) Format	91
6-4.	External Circuit of Main System Clock Oscillator	92
6-5.	Incorrect Examples of Resonator Connection	93
6-6.	Switching CPU Clock	97
7-1.	Timer 0 (TM0) Block Diagram	101
7-2.	16-Bit Timer Mode Control Register (TMC0) Format	103
7-3.	Capture Pulse Control Register (CRC0) Format	104
7-4.	Prescaler Mode Register (PRM0) Format	105
7-5.	Configuration Diagram for Pulse Width Measurement by Free-Running Counter	106
7-6.	Timing of Pulse Width Measurement Operation by Free-Running Counter and One Capture Register (with Both Edges Specified)	106

LIST OF FIGURES (2/4)

Figure No.	Title	Page
7-7.	CR0m Capture Operation with Rising Edge Specified	107
7-8.	Timing of Pulse Width Measurement Operation by Free-Running Counter (with Both Edges Specified)	108
7-9.	16-Bit Timer Register Start Timing	109
7-10.	Capture Register Data Retention Timing	109
8-1.	Timer 1 (TM1) Block Diagram	111
8-2.	Timer Clock Select Register 1 (TCL1) Format	113
8-3.	8-Bit Timer Mode Control Register 1 (TMC1) Format	114
8-4.	Interval Timer Operation Timings	115
8-5.	Timer 1 Start Timing	118
8-6.	Timing after Compare Register Change during Timer Count Operation	118
9-1.	Timer 2 (TM2) Block Diagram	119
9-2.	Timer 3 (TM3) Block Diagram	120
9-3.	Timer Clock Select Register 2 (TCL2) Format	122
9-4.	Timer Clock Select Register 3 (TCL3) Format	123
9-5.	8-Bit Timer Mode Control Register n (TMCn) Format	124
9-6.	Interval Timer Operation Timings	125
9-7.	External Event Counter Operation Timings (with Rising Edge Specified)	128
9-8.	PWM Output Operation Timing	130
9-9.	Timing of Operation by Change of CRn	131
9-10.	Timer n Start Timing	132
9-11.	Timing after Compare Register Change during Timer Count Operation	132
10-1.	Watch Timer Block Diagram	133
10-2.	Watch Timer Mode Control Register (WTM) Format	135
10-3.	Operation Timing of Watch Timer/Interval Timer	137
11-1.	Watchdog Timer Block Diagram	139
11-2.	Watchdog Timer Clock Select Register (WDCS) Format	141
11-3.	Watchdog Timer Mode Register (WDTM) Format	142
12-1.	Clock Output Control Circuit Block Diagram	145
12-2.	Clock Output Selection Register (CKS) Format	146
12-3.	Port Mode Register 6 (PM6) Format	147
12-4.	Remote Control Output Application Example	148
13-1.	A/D Converter Block Diagram	149
13-2.	Power-Fail Detection Function Block Diagram	150
13-3.	A/D Converter Mode Register (ADM1) Format	152
13-4.	Analog Input Channel Specification Register (ADS1) Format	153
13-5.	Power-Fail Compare Mode Register (PFM) Format	154
13-6.	Basic Operation of 8-Bit A/D Converter	156
13-7.	Relation between Analog Input Voltage and A/D Conversion Result	157

LIST OF FIGURES (3/4)

Figure No.	Title	Page
13-8.	A/D Conversion	159
13-9.	Example of Method of Reducing Current Consumption in Standby Mode	160
13-10.	Analog Input Pin Connection	161
13-11.	A/D Conversion End Interrupt Request Generation Timing	162
13-12.	D/A Converter Mode Register (DAM1) Format	163
14-1.	UART Block Diagram	165
14-2.	Asynchronous Serial Interface Mode Register (ASIM) Format	168
14-3.	Asynchronous Serial Interface Status Register (ASIS) Format	169
14-4.	Baud Rate Generator Control Register (BRGC) Format	170
14-5.	Error Tolerance (when k = 0) including Sampling Errors	176
14-6.	Format of Transmit/Receive Data in Asynchronous Serial Interface	177
14-7.	Timing of Asynchronous Serial Interface Transmit Completion Interrupt	179
14-8.	Timing of Asynchronous Serial Interface Receive Completion Interrupt	180
14-9.	Receive Error Timing	181
15-1.	SIO3 Block Diagram	183
15-2.	Serial Operation Mode Register (CSIM) Format	185
15-3.	Serial Operation Mode Register (CSIM) Format	186
15-4.	Serial Operation Mode Register (CSIM) Format	187
15-5.	Three-Wire Serial I/O Mode Timing	188
16-1.	LCD Controller/Driver Block Diagram	190
16-2.	LCD Clock Select Circuit Block Diagram	191
16-3.	LCD Display Mode Register (LCDM) Format	192
16-4.	LCD Display Control Register (LCDC) Format	193
16-5.	Relationship between LCD Display Data Memory Contents and Segment/Common Outputs	195
16-6.	Common Signal Waveform	197
16-7.	Common Signal and Segment Signal Voltages and Phases	197
16-8.	Example of Connection of LCD Drive Power Supply	199
16-9.	4-Time-Division LCD Display Pattern and Electrode Connections	200
16-10.	4-Time-Division LCD Panel Connection Example	201
16-11.	4-Time-Division LCD Drive Waveform Examples (1/3 Bias Method)	202
16-12.	LCD Timer Control Register (LCDTM) Format	203
17-1.	Sound Generator Block Diagram	205
17-2.	Concept of Each Signal	206
17-3.	Sound Generator Control Register (SGCR) Format	208
17-4.	Sound Generator Buzzer Control Register (SGBR) Format	210
17-5.	Sound Generator Amplitude Register (SGAM) Format	211
17-6.	Sound Generator Output Operation Timing	212
17-7.	Sound Generator Output Operation Timing	212

LIST OF FIGURES (4/4)

Figure No.	Title	Page
18-1.	Meter Controller/Driver Block Diagram	213
18-2.	1-Bit Addition Circuit Block Diagram	214
18-3.	Timer Mode Control Register (MCNTC) Format	216
18-4.	Compare Control Register n (MCMPCn) Format	217
18-5.	Port Mode Control Register (PMC) Format	218
18-6.	Restart Timing after Count Stop (Count Start→Count Stop→Count Start)	220
18-7.	Timing in 1-Bit Addition Circuit Operation	221
18-8.	Timing of Output with 1 Clock Shifted	222
19-1.	Basic Configuration of Interrupt Function	225
19-2.	Interrupt Request Flag Register (IF0L, IF0H, IF1L) Format	228
19-3.	Interrupt Mask Flag Register (MK0L, MK0H, MK1L) Format	229
19-4.	Priority Specify Flag Register (PR0L, PR0H, PR1L) Format	230
19-5.	External Interrupt Rising Edge Enable Register (EGP), External Interrupt Falling Edge Enable Register (EGN) Format	231
19-6.	Prescaler Mode Register (PRM0) Format	232
19-7.	Program Status Word Format	233
19-8.	Non-Maskable Interrupt Request Generation to Acknowledge Flowchart	235
19-9.	Non-Maskable Interrupt Request Acknowledge Timing	235
19-10.	Non-Maskable Interrupt Request Acknowledge Operation	236
19-11.	Interrupt Request Acknowledge Processing Algorithm	238
19-12.	Interrupt Request Acknowledge Timing (Minimum Time)	239
19-13.	Interrupt Request Acknowledge Timing (Maximum Time)	239
19-14.	Multiple Interrupt Examples	241
19-15.	Interrupt Request Hold	243
20-1.	Oscillation Stabilization Time Select Register (OSTS) Format	246
20-2.	HALT Mode Clear upon Interrupt Generation	248
20-3.	HALT Mode Clear upon $\overline{\text{RESET}}$ Input	249
20-4.	STOP Mode Clear upon Interrupt Generation	251
20-5.	STOP Mode Clear upon $\overline{\text{RESET}}$ Input	252
21-1.	Reset Function Block Diagram	253
21-2.	Timing of Reset by $\overline{\text{RESET}}$ Input	254
21-3.	Timing of Reset due to Watchdog Timer Overflow	254
21-4.	Timing of Reset in STOP Mode by $\overline{\text{RESET}}$ Input	254
22-1.	Memory Size Switching Register (IMS) Format	258
22-2.	Transmission Method Selection Format	259
22-3.	Flashpro II Connection Using 3-Wire Serial I/O Method	260
22-4.	Flashpro II Connection Using UART Method	261
22-5.	Flashpro II Connection Using Pseudo 3-Wire Serial I/O Method	261
A-1.	Development Tool Configuration	280
A-2.	Dimensions of TGF-080RAP (Reference)	289

LIST OF TABLES (1/2)

Table No.	Title	Page
2-1.	Pin Input/Output Circuit Types	38
3-1.	Internal Memory Capacity	43
3-2.	Vector Table	43
3-3.	Internal High-Speed RAM Capacity	44
3-4.	Internal High-Speed RAM Area	48
3-5.	Special Function Register List	52
5-1.	Port Functions	74
5-2.	Port Configuration	75
5-3.	Port Mode Register and Output Latch Settings when Using Alternate Functions	85
6-1.	Clock Generator Configuration	89
6-2.	Relation between CPU Clock and Minimum Instruction Execution Time	90
6-3.	Maximum Time Required for Switching CPU Clock	96
7-1.	Timer/Event Counter Operations	100
7-2.	Timer 0 Configuration	102
8-1.	Timer 1 Configuration	112
9-1.	Timers 2 and 3 Configurations	121
10-1.	Interval Timer Interval Time	134
10-2.	Watch Timer Configuration	134
10-3.	Interval Timer Interval Time	136
11-1.	Watchdog Timer Runaway Detection Time	140
11-2.	Interval Time	140
11-3.	Watchdog Timer Configuration	141
11-4.	Watchdog Timer Runaway Detection Time	143
11-5.	Interval Timer Interval Time	144
12-1.	Clock Output Control Circuit Configuration	145
13-1.	A/D Converter Configuration	150
14-1.	UART Configuration	166
14-2.	Relation between 5-bit Counter's Source Clock and "n" Value	175
14-3.	Relation between Main System Clock and Baud Rate	176
14-4.	Causes of Receive Errors	181
15-1.	SIO3 Configuration	184

LIST OF TABLES (2/2)

Table No.	Title	Page
16-1.	Maximum Number of Display Pixels	189
16-2.	LCD Controller/Driver Configuration	190
16-3.	COM Signals	196
16-4.	LCD Drive Voltage	196
16-5.	LCD Drive Voltage	198
16-6.	Selection and Non-Selection Voltages (COM0 to COM3)	200
17-1.	Sound Generator Configuration	206
18-1.	Meter Controller/Driver Configuration	214
19-1.	Interrupt Source List	224
19-2.	Flags Corresponding to Interrupt Request Sources	227
19-3.	Times from Generation of Maskable Interrupt Request until Servicing	237
19-4.	Interrupt Request Enabled for Multiple Interrupt during Interrupt Servicing	240
20-1.	HALT Mode Operating Status	247
20-2.	Operation after HALT Mode Clear	249
20-3.	STOP Mode Operating Status	250
20-4.	Operation after STOP Mode Clear	252
21-1.	Hardware Status after Reset	255
22-1.	Differences between μ PD78F0974 and μ PD780973(A)	257
22-2.	Memory Size Switching Register Settings	258
22-3.	Transmission Method List	259
22-4.	Main Functions of Flash Memory Programming	260
23-1.	Operand Identifiers and Description Formats	264
A-1.	Upgrading Former In-circuit Emulator for 78K/0 Series to IE-78001-R-A	288

CHAPTER 1 OUTLINE

1.1 Features

- Internal memory

Item Part Number	Program Memory (ROM/Flash Memory)	Data Memory		
		Internal High-Speed RAM	LCD Display RAM	EEPROM™
μPD780973(A)	24 Kbytes	768 bytes	20 × 4 bits	256 bytes
μPD78F0974	32 Kbytes	1024 bytes		

- High-speed instruction execution time (0.24 μs: @ 8.38-MHz operation with main system clock)
- Instruction set suited to system control
 - Bit manipulation possible in all address spaces
 - Multiply and divide instructions
- Fifty-six I/O ports : (including pins that have an alternate function as segment signal output)
- LCD controller/driver
 - Segment signal output : 20 max.
 - Common signal output : 4 max.
 - Bias : 1/3 bias
 - Power supply voltage : $V_{LCD} = 3.0\text{ V to }V_{DD}$
- 8-bit resolution A/D converter : 5 channels
- Serial interface : 2 channels
 - 3-wire serial I/O mode : 1 channel
 - UART mode : 1 channel
- Timer : Six channels
 - 16-bit timer : 1 channel
 - 8-bit timer : 1 channel
 - 8-bit timer/event counter : 2 channels
 - Watch timer : 1 channel
 - Watchdog timer : 1 channel
- Meter controller/driver : PWM output (8-bit resolution) : 16
 - : Can set pulse width with a precision of 8 + 1 bits with 1-bit addition function
- Sound generator : 1 channel
- Vectored interrupt sources : 21
- Power supply voltage : $V_{DD} = 5\text{ V} \pm 10\%$

1.2 Applications

Automobile meter (dash board) control

1.3 Ordering Information

Part Number	Package	Internal ROM
μ PD780973GF(A)-xxx-3B9	80-pin plastic QFP (14 × 20 mm)	Mask ROM
μ PD78F0974GF-3B9	80-pin plastic QFP (14 × 20 mm)	Flash memory

1.4 Quality Grade

Part Number	Package	Quality Grade
μ PD78F0974GF-3B9	80-pin plastic QFP (14 × 20 mm)	Standard
μ PD780973GF(A)-xxx-3B9	80-pin plastic QFP (14 × 20 mm)	Special

Remark xxx indicates ROM code suffix.

Please refer to "Quality Grades on NEC Semiconductor Devices" (Document No. C11531E) published by NEC Corporation to know the specification of quality grade on the devices and its recommended applications.

1.5 Pin Configuration (Top View)

- **80-pin plastic QFP (14 × 20 mm)**
 μ PD780973GF(A)-xxx, 78F0974GF

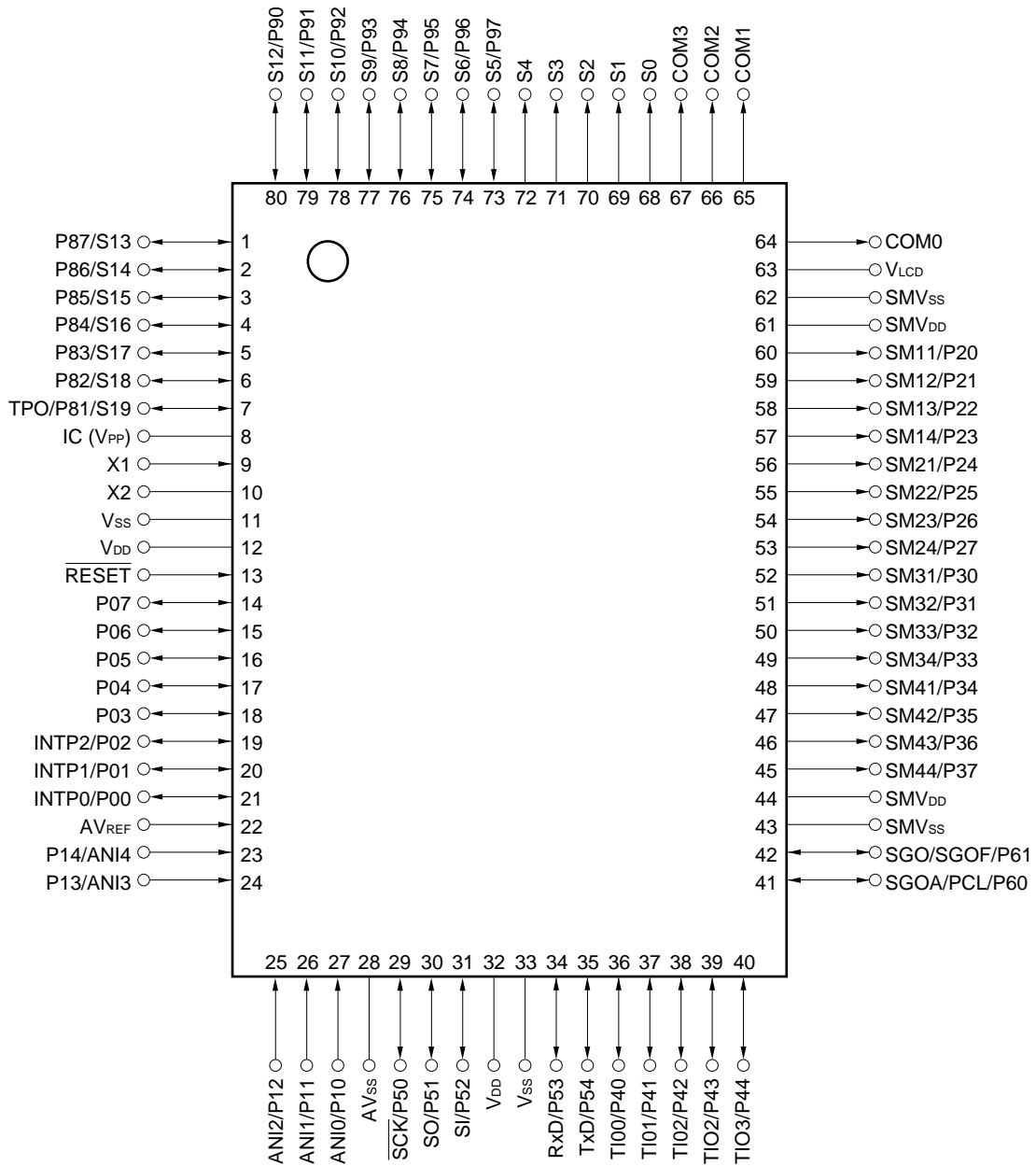

- Cautions**
1. Connect IC (Internally Connected) pin to Vss directly.
 2. Connect AVss pin to Vss.

- Remarks**
1. When these devices are used in applications that require reduction of the noise generated from inside the microcontroller, the implementation of noise reduction measures, such as supplying voltage to the two VDD individually, and connecting the two Vss to different ground lines, is recommended.
 2. Pin connection in parentheses is intended for the μ PD78F0974.

ANI0 to ANI4	: Analog Input	\overline{SCK}	: Serial Clock
AV _{REF}	: Analog Reference Voltage	SGO	: Sound Generator Output
AV _{SS}	: Analog Ground	SGOA	: Sound Generator Amplitude Output
COM0 to COM3	: Common Output	SGOF	: Sound Generator Frequency Output
IC	: Internally Connected	SI	: Serial Input
INTP0 to INTP2	: Interrupt from Peripherals	SM11 to SM14, SM21 to SM24, SM31 to SM34, SM41 to SM44	
P00 to P07	: Port0		: Meter Output
P10 to P14	: Port1	SMV _{DD}	: Meter Controller Power Supply
P20 to P27	: Port2	SMV _{SS}	: Meter Controller Ground
P30 to P37	: Port3	SO	: Serial Output
P40 to P44	: Port4	TI00 to TI02	: Timer Input
P50 to P54	: Port5	TIO2, TIO3	: Timer Output/Event Counter Input
P60, P61	: Port6	TPO	: Prescaler Output
P81 to P87	: Port8	TxD	: Transmit Data
P90 to P97	: Port9	V _{DD}	: Power Supply
PCL	: Clock Output	V _{LCD}	: LCD Power Supply
\overline{RESET}	: Reset	V _{PP}	: Programming Power Supply
RxD	: Receive Data	V _{SS}	: Ground
S0 to S19	: Segment Output	X1, X2	: Crystal (Main System Clock)

1.6 78K/0 Series Product Development

These products are a further development in the 78K/0 Series. The designations appearing inside the boxes are subseries names.

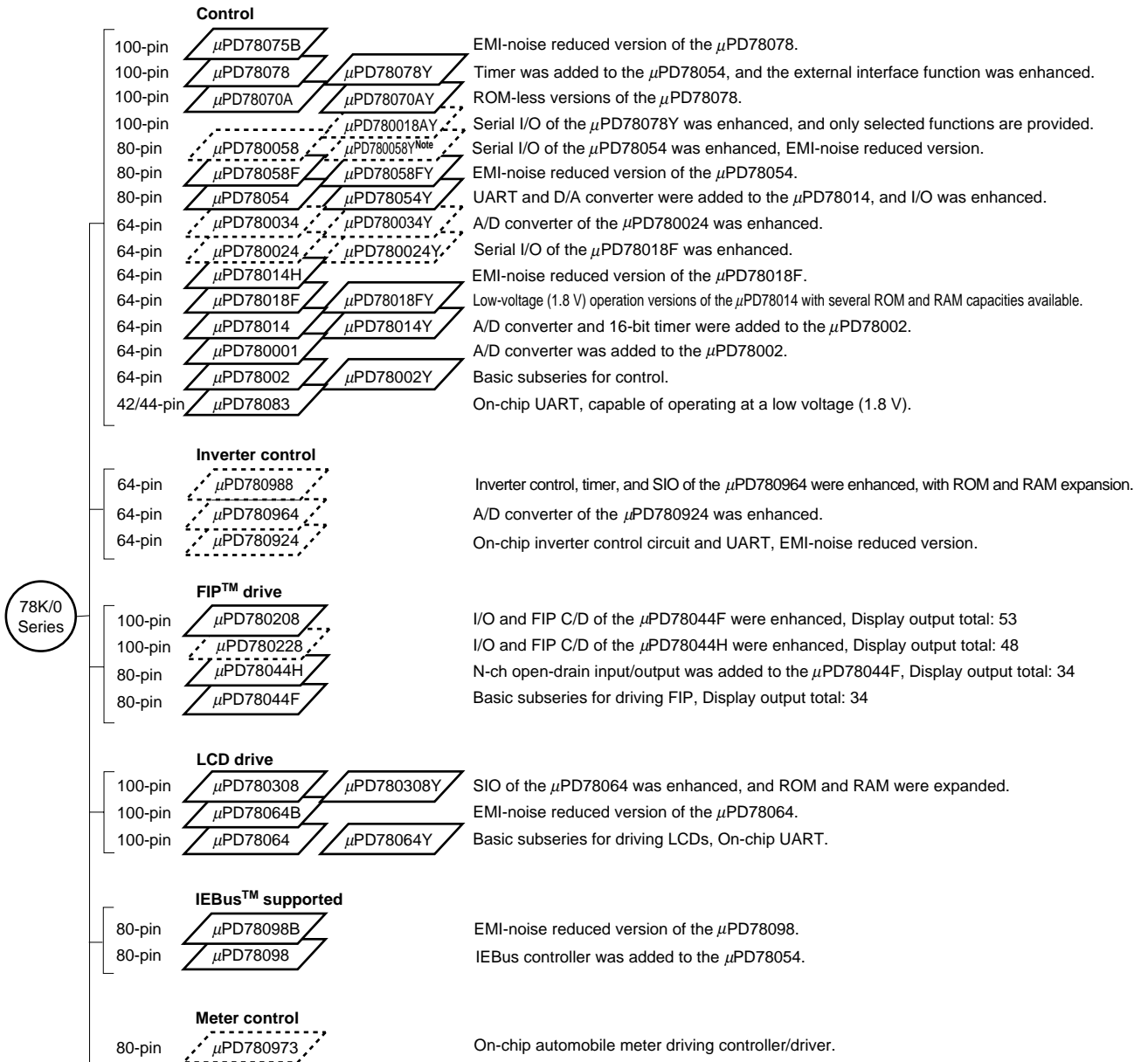
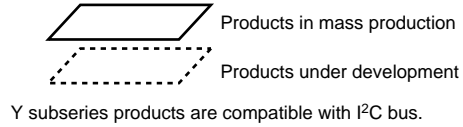

Note Under planning

The major functional differences among the subseries are shown below.

Function Subseries Name		ROM Capacity	Timer				8-bit A/D	10-bit A/D	8-bit D/A	Serial Interface	I/O	V _{DD} MIN. Value	External Expansion							
			8-bit	16-bit	Watch	WDT														
Control	μPD78075B	32 K to 40 K	4 ch	1 ch	1 ch	1 ch	8 ch	-	2 ch	3 ch (UART: 1 ch)	88	1.8 V	Available							
	μPD78078	48 K to 60 K									61	2.7 V								
	μPD78070A	-																		
	μPD780058	24 K to 60 K	2 ch							3 ch (time-division UART: 1ch)	68	1.8 V								
	μPD78058F	48 K to 60 K									69	2.7 V								
	μPD78054	16 K to 60 K								51				1.8 V						
	μPD780034	8 K to 32 K									-	8 ch			-	3 ch (UART: 1 ch, time- division 3-wire: 1 ch)				
	μPD780024									8 ch				-			2 ch	53		
	μPD78014H																			
	μPD78018F	8 K to 60 K								-	-	-		-	-	-	-	-	-	
	μPD78014	8 K to 32 K																		
	μPD780001	8 K								-	-	-		-	-	-	-	-	-	-
	μPD78002	8 K to 16 K																		
μPD78083	8 K																			
Inverter control	μPD780988	32 K to 60 K	3 ch	Note 1	-	1 ch	-	8 ch	-	3 ch (UART: 2 ch)	47	4.0 V	Available							
	μPD780964	8 K to 32 K									2 ch (UART: 2 ch)	2.7 V								
	μPD780924	8 K to 32 K								8 ch				-						
FIP drive	μPD780208	32 K to 60 K	2 ch	1 ch	1 ch	1 ch	8 ch	-	-	2 ch	74	2.7 V	-							
	μPD780228	48 K to 60 K	3 ch	-	-	-	-	-	-	1 ch	72	4.5 V								
	μPD78044H	32 K to 48 K	2 ch	1 ch	1 ch	-	-	-	-	-	68	2.7 V								
	μPD78044F	16 K to 40 K	-	-	-	-	-	-	-	2 ch	-	-								
LCD drive	μPD780308	48 K to 60 K	2 ch	1 ch	1 ch	1 ch	8 ch	-	-	3 ch (time-division UART: 1 ch)	57	2.0 V	-							
	μPD78064B	32 K												2 ch (UART: 1 ch)						
	μPD78064	16 K to 32 K																		
IEBus supported	μPD78098B	40 K to 60 K	2 ch	1 ch	1 ch	1 ch	8 ch	-	2 ch	3 ch (UART: 1 ch)	69	2.7 V	Available							
	μPD78098	32 K to 60 K																		
Meter control	μPD780973	24 K to 32 K	3 ch	1 ch	1 ch	1 ch	5 ch	-	-	2 ch (UART: 1 ch)	56	4.5 V	-							

Notes 1. 16-bit timer: 2 channels

10-bit timer: 1 channel

2. 10-bit timer: 1 channel

1.7 Block Diagram

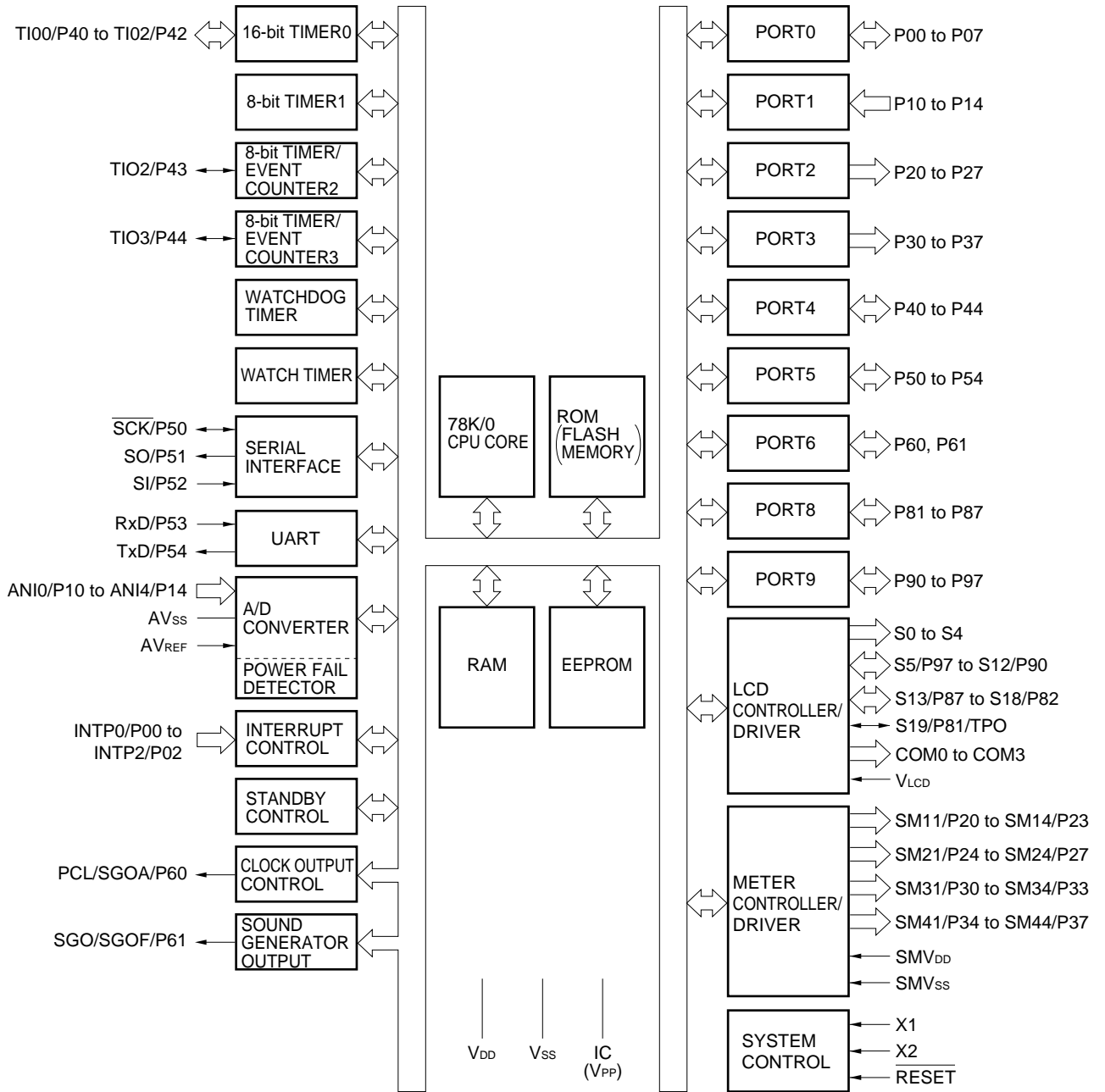

- Remarks 1.** The internal ROM and RAM capacities depend on the product.
2. Memory type in parentheses is for the μ PD78F0974.

1.8 Outline of Function

Part Number		μ PD780973(A)	μ PD78F0974
Internal memory	ROM	24 Kbytes (Mask ROM)	32 Kbytes (Flash memory)
	Internal high-speed RAM	768 bytes	1024 bytes
	EEPROM	256 bytes	
	LCD display RAM	20 × 4 bits	
General register		8 bits × 32 registers (8 bits × 8 registers × 4 banks)	
Minimum instruction execution time		0.24 μ s/0.48 μ s/0.95 μ s/1.91 μ s/3.81 μ s (in operation at 8.38 MHz)	
Instruction set		<ul style="list-style-type: none"> • 16-bit operation • Multiply/divide (8 bits × 8 bits, 16 bits ÷ 8 bits) • Bit manipulation (set, reset, test, and Boolean operation) 	
I/O port (including pins shared with segment signal output)		Total : 56 <ul style="list-style-type: none"> • CMOS input : 5 • CMOS output : 16 • CMOS input/output : 35 	
A/D converter		<ul style="list-style-type: none"> • 8-bit resolution × 5 channels • Power-fail detection function 	
LCD controller/driver		<ul style="list-style-type: none"> • Segment signal outputs : 20 max. • Common signal outputs : 4 max. • Bias : 1/3 bias only 	
Serial interface		<ul style="list-style-type: none"> • 3-wire serial I/O mode : 1 channel • UART mode : 1 channel 	
Timer		<ul style="list-style-type: none"> • 16-bit timer : 1 channel • 8-bit timer : 1 channel • 8-bit timer/event counter : 2 channels • Watch timer : 1 channel • Watchdog timer : 1 channel 	
Meter control		PWM output (8-bit resolution) : 16 Can set pulse width with a precision of 8 + 1 bits with 1-bit addition function	
Sound generator		1 channel	
Clock output		65.5 kHz, 131 kHz, 262 kHz, 524 kHz, 1.04 MHz, 2.09 MHz, 4.19 MHz, 8.38 MHz (@ 8.38-MHz operation with main system clock)	
Vectored interrupt source	Maskable	Internal: 16, External: 3	
	Non-maskable	Internal: 1	
	Software	1	
Power supply voltage		V_{DD} (SMV _{DD}) = 5 V ±10%	
Operating ambient temperature		T_A = -40 to +85°C	
Package		80-pin plastic QFP (14 × 20 mm)	

CHAPTER 2 PIN FUNCTION

2.1 Pin Function List

(1) Port Pins

Pin Name	Input/Output	Function	After Reset	Alternate Function
P00 to P02	Input/Output	Port 0 8-bit input/output port. Input/output mode can be specified bit-wise. If used as an input port, an on-chip pull-up resistor can be used by software.	Input	INTP0 to INTP2
P03 to P07				—
P10 to P14	Input	Port 1 5-bit input only port.	Input	ANI0 to ANI4
P20 to P23	Output	Port 2 8-bit output only port.	Hi-Z	SM11 to SM14
P24 to P27				SM21 to SM24
P30 to P33	Output	Port 3 8-bit output only port.	Hi-Z	SM31 to SM34
P34 to P37				SM41 to SM44
P40 to P42	Input/Output	Port 4 5-bit input/output port. Input/output mode can be specified bit-wise.	Input	TI00 to TI02
P43, P44				TIO2, TIO3
P50	Input/Output	Port 5 5-bit input/output port. Input/output mode can be specified bit-wise.	Input	SCK
P51				SO
P52				SI
P53				RxD
P54				TxD
P60	Input/Output	Port 6 2-bit input/output port. Input/output mode can be specified bit-wise.	Input	PCL/SGOA
P61				SGO/SGOF
P81	Input/Output	Port 8 7-bit input/output port. Input/output mode can be specified bit-wise. Can be set in I/O port mode or segment output mode in 2-bit units by using LCD display control register (LCDC).	Input	S19/TPO
P82 to P87				S18 to S13
P90 to P97	Input/Output	Port 9 8-bit input/output port. Input/output mode can be specified bit-wise. Can be set in I/O port mode or segment output mode in 2-bit units by using LCD display control register (LCDC).	Input	S12 to S5

(2) Non-port pins

Pin Name	Input/Output	Function	After Reset	Alternate Function
INTP0 to INTP2	Input	External interrupt request input with specifiable valid edges (rising edge, falling edge, both rising and falling edges).	Input	P00 to P02
SI	Input	Serial interface serial data input.	Input	P52
SO	Output	Serial interface serial data output.	Input	P51
$\overline{\text{SCK}}$	Input/Output	Serial interface serial data input/output.	Input	P50
RxD	Input	Asynchronous serial interface serial data input.	Input	P53
TxD	Output	Asynchronous serial interface serial data output.	Input	P54
TI00	Input	Capture trigger signal input to capture register (CR00).	Input	P40
TI01		Capture trigger signal input to capture register (CR01).		P41
TI02		Capture trigger signal input to capture register (CR02).		P42
TIO2	Input/Output	8-bit timer (TM2) input/output.	Input	P43
TIO3		8-bit timer (TM3) input/output.		P44
PCL	Output	Clock output (for main system clock trimming).	Input	SGOA/P60
SGOA	Output	Sound generator signal output.	Input	PCL/P60
SGOF				SGO/P61
SGO				SGOF/P61
TPO	Output	Prescaler output of 16-bit timer (TM0).	Input	P81/S19
S0 to S4	Output	Segment signal output of LCD controller/driver.	Output	—
S5 to S12			Input	P97 to P90
S13 to S18				P87 to P82
S19				P81/TPO
COM0 to COM3	Output	Common signal output of LCD controller/driver.	Output	—
V _{Lcd}	—	LCD driving power supply.	—	—
SM11 to SM14	Output	Meter control signal output.	Hi-Z	P20 to P23
SM21 to SM24				P24 to P27
SM31 to SM34				P30 to P33
SM41 to SM44				P34 to P37
ANI0 to ANI4	Input	A/D converter analog input.	Input	P10 to P14
AV _{REF}	Input	A/D converter reference voltage input (shared with analog power supply).	—	—
AV _{SS}	—	A/D converter ground potential. Same potential as V _{SS} .	—	—
$\overline{\text{RESET}}$	Input	System reset input.	—	—
X1	Input	Crystal connection for main system clock oscillation.	—	—
X2	—		—	—
SMV _{DD}	—	Power supply for meter controller/driver.	—	—
SMV _{SS}	—	Ground potential for meter controller/driver.	—	—
V _{DD}	—	Positive power supply.	—	—
V _{SS}	—	Ground potential.	—	—
V _{PP}	—	High-voltage application for program write/verify. Connect directly to V _{SS} in normal operating mode.	—	—
IC	—	Internally connected. Connect directly to V _{SS} .	—	—

2.2 Description of Pin Functions

2.2.1 P00 to P07 (Port 0)

These pins constitute an 8-bit input/output port. In addition, they are also used to input external interrupt request signals.

The following operating modes can be specified bit-wise.

(1) Port mode

In this mode, P00 to P07 function as an 8-bit input/output port.

P00 to P07 can be specified as an input or output port bit-wise with port mode register 0 (PM0). When these pins are used as an input port, an on-chip pull-up resistor can be used if so specified by the pull-up resistor option register (PU0).

(2) Control mode

In this mode, P00 to P07 function as external interrupt input pins (INTP0 to INTP2) and external interrupt request input pins with specifiable valid edges (rising edge, falling edge, both rising and falling edges).

2.2.2 P10 to P14 (Port 1)

These pins constitute a 5-bit input only port. In addition, they are also used to input A/D converter analog signals.

The following operating modes can be specified bit-wise.

(1) Port mode

In this mode, P10 to P14 function as a 5-bit input only port.

(2) Control mode

In this mode, P10 to P14 function as A/D converter analog input pins (ANI0 to ANI4).

2.2.3 P20 to P27 (Port 2)

These pins constitute an 8-bit output only port. In addition, they are also used as PWM output pins to control meters.

The following operating modes can be specified bit-wise.

(1) Port mode

In this mode, P20 to P27 function as an 8-bit output only port. They go into a high-impedance state when 1 is set to port mode register 2 (PM2).

(2) Control mode

In this mode, P20 to P27 function as PWM output pins (SM11 to SM14 and SM21 to SM24) for meter control.

2.2.4 P30 to P37 (Port 3)

These pins constitute an 8-bit output only port. In addition, they also function as PWM output pins to control meters. The following operating modes can be specified bit-wise.

(1) Port mode

In this mode, P30 to P37 function as an 8-bit output only port. They go into a high-impedance state when 1 is set to port mode register 3 (PM3).

(2) Control mode

In this mode, P30 to P37 function as PWM output pins (SM31 to SM34 and SM41 to SM44) for meter control.

2.2.5 P40 to P44 (Port 4)

These pins constitute a 5-bit input/output port. In addition, they also function as timer input/output pins. The following operating modes can be specified bit-wise.

(1) Port mode

In this mode, P40 to P44 function as a 5-bit input/output port. They can be set bit-wise in the input or output mode by using port mode register 4 (PM4).

(2) Control mode

In this mode, P40 to P44 function as timer input/output pins.

(a) TIO2, TIO3

Timer output pins.

(b) TI00 to TI02

These pins input a capture trigger signal to the 16-bit timer capture registers (CR00 to CR02).

2.2.6 P50 to P54 (Port 5)

These pins constitute a 5-bit input/output port. In addition, they also function as serial interface data input/output and clock input/output pins.

The following operating modes can be specified bit-wise.

(1) Port mode

In this mode, P50 to P54 function as a 5-bit input/output port. They can be set bit-wise in the input or output mode by using port mode register 5 (PM5).

(2) Control mode

In this mode, P50 to P54 function as serial interface data input/output and clock input/output.

(a) SI

Serial interface serial data input pin.

(b) SO

Serial interface serial data output pin.

(c) $\overline{\text{SCK}}$

Serial interface serial clock input/output pin.

(d) RxD, TxD

Asynchronous serial interface serial data input/output pins.

2.2.7 P60, P61 (Port 6)

These pins constitute a 2-bit input/output port. In addition, they also function as clock output and sound generator output pins.

The following operating modes can be specified bit-wise.

(1) Port mode

In this mode, P60 and P61 function as a 2-bit input/output port. They can be set bit-wise in the input or output mode by using port mode register 6 (PM6).

(2) Control mode

In this mode, P60 and P61 function as clock output and sound generator output pins.

(a) PCL

Clock output pin.

(b) SGOF

Sound generator (without amplitude) signal output pin.

(c) SGO

Sound generator (with amplitude) signal output pin.

(d) SGOA

Sound generator amplitude signal output pin.

2.2.8 P81 to P87 (Port 8)

These pins constitute a 7-bit input/output port. In addition, they also function as output pins for segment signals from the internal LCD controller/driver, and one of them as a prescaler signal output pin.

The following operating modes can be specified bit-wise.

(1) Port mode

In this mode, P81 to P87 function as a 7-bit input/output port. They can be set bit-wise in the input or output mode by using port mode register 8 (PM8).

(2) Control mode

In this mode, P81 to P87 function as segment signal output pins of the LCD controller/driver, and one of them as a prescaler signal output pins.

(a) S13 to S19

Segment signal output pins of the LCD controller/driver.

(b) TPO

Prescaler signal output pin of the 16-bit timer.

2.2.9 P90 to P97 (Port 9)

These pins constitute an 8-bit input/output port. In addition, they also function to output segment signals from the internal LCD controller/driver.

The following operating modes can be specified bit-wise.

(1) Port mode

In this mode, P90 to P97 function as an 8-bit input/output port. They can be set bit-wise in the input or output mode by using port mode register 9 (PM9).

(2) Control mode

In this mode, P90 to P97 function as segment signal output pins (S5 to S12) of the LCD controller/driver.

2.2.10 COM0 to COM3

These pins output common signals from the internal LCD controller/driver during 4-time division drive in 1/3 bias mode (COM0 to COM3 outputs).

2.2.11 V_{LCD}

This pin supplies a voltage to drive an LCD.

2.2.12 AV_{REF}

This is an A/D converter reference voltage input pin. This pin also functions as an analog power supply pin. Supply power to this pin when the A/D converter is used.

When A/D converter is not used, connect this pin to V_{ss}.

2.2.13 AV_{ss}

This is a ground voltage pin of A/D converter. Always use the same voltage as that of the V_{ss} pin even when an A/D converter is not used.

2.2.14 $\overline{\text{RESET}}$

This is a low-level active system reset input pin.

2.2.15 X1 and X2

Crystal resonator connect pins for main system clock oscillation. When using an external clock supply, input it to X1 and its inverted signal to X2.

2.2.16 SMV_{DD}

This pin supplies a positive power to the meter controller/driver.

2.2.17 SMV_{ss}

This is the ground pin of the meter controller/driver.

2.2.18 V_{DD}

Positive power supply port pin.

2.2.19 V_{ss}

Ground potential port pin.

2.2.20 V_{PP} (μ PD78F0974)

A high voltage should be applied to this pin when the flash memory programming mode is set and when the program is written or verified. Directly connect this pin to V_{ss} in the normal operating mode.

2.2.21 IC (μ PD780973(A))

The IC (Internally Connected) pin is provided to set the test mode to check the μ PD780973(A) before shipment. In the normal operating mode, directly connect this pin to the V_{ss} pin with as short a wiring length as possible.

When a potential difference is generated between the IC pin and V_{ss} pin because the wiring between those two pins is too long or external noise is input to the IC pin, the user's program may not run normally.

- Directly connect the IC pin to the V_{ss} pin.

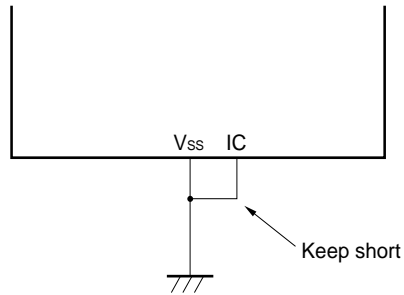

2.3 Input/output Circuits and Recommended Connection of Unused Pins

Table 2-1 shows the input/output circuit types of pins and the recommended connection for unused pins. Refer to Figure 2-1 for the configuration of the input/output circuit of each type.

Table 2-1. Pin Input/Output Circuit Types

Pin Name	Input/Output Circuit Type	Input/Output	Recommended Connection of Unused Pins
P00/INTP0	8-A	Input/output	Independently connect to V _{SS} via a resistor.
P01/INTP1			
P02/INTP2			
P03 to P07			
P10/ANI0 to P14/ANI4	9	Input	Independently connect to V _{DD} or V _{SS} via a resistor.
P20/SM11 to P23/SM14	4	Output	Leave open.
P24/SM21 to P27/SM24			
P30/SM31 to P33/SM34			
P34/SM41 to P37/SM44			
P40/TIO0 to P42/TIO2	8	Input/output	Independently connect to V _{DD} or V _{SS} via a resistor.
P43/TIO2			
P44/TIO3			
P50/ $\overline{\text{SCK}}$			
P51/SO	5		
P52/SI	8		
P53/RxD			
P54/TxD	5		
P60/SGOA/PCL			
P61/SGO/SGOF			
★ P81/S19/TPO		17-G	
P82/S18 to P87/S13			
P90/S12 to P97/S5			
S0 to S4	17	Output	Leave open.
COM0 to COM3	18		
V _{LCD}	—	—	
$\overline{\text{RESET}}$	2	Input	—
SMV _{DD}	—	—	Connect to V _{DD} .
SMV _{SS}			Connect to V _{SS} .
AV _{REF}			
AV _{SS}			
V _{PP} ($\mu\text{PD78F0974}$)			
IC ($\mu\text{PD780973(A)}$)			Connect directly to V _{SS} .

Figure 2-1. I/O Circuits of Pins (1/2)

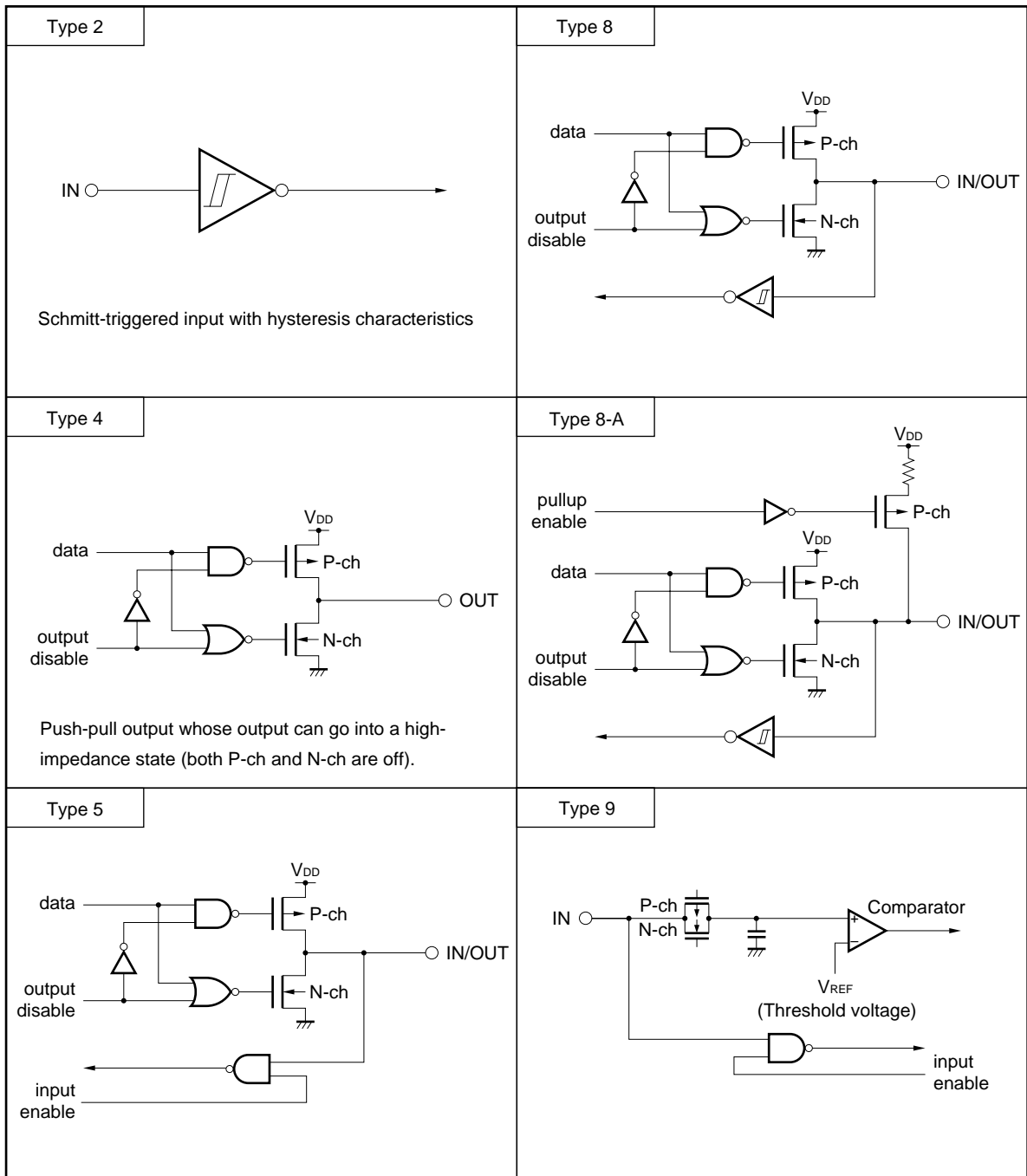
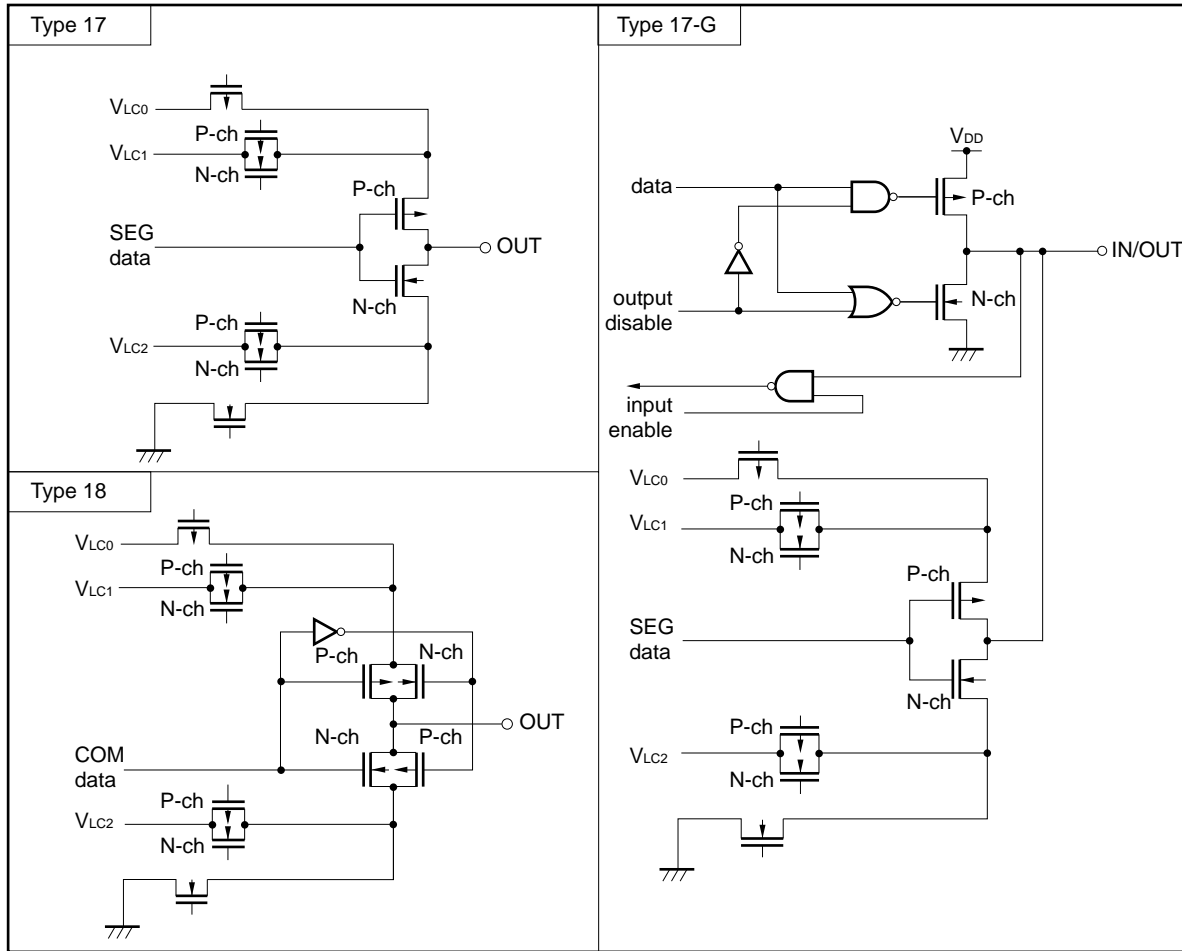

Figure 2-1. I/O Circuits of Pins (2/2)

★



CHAPTER 3 CPU ARCHITECTURE

3.1 Memory Spaces

The μ PD780973 Subseries can access a 64-Kbyte memory space. Figures 3-1 and 3-2 show memory maps of the respective devices.

Figure 3-1. Memory Map (μ PD780973(A))

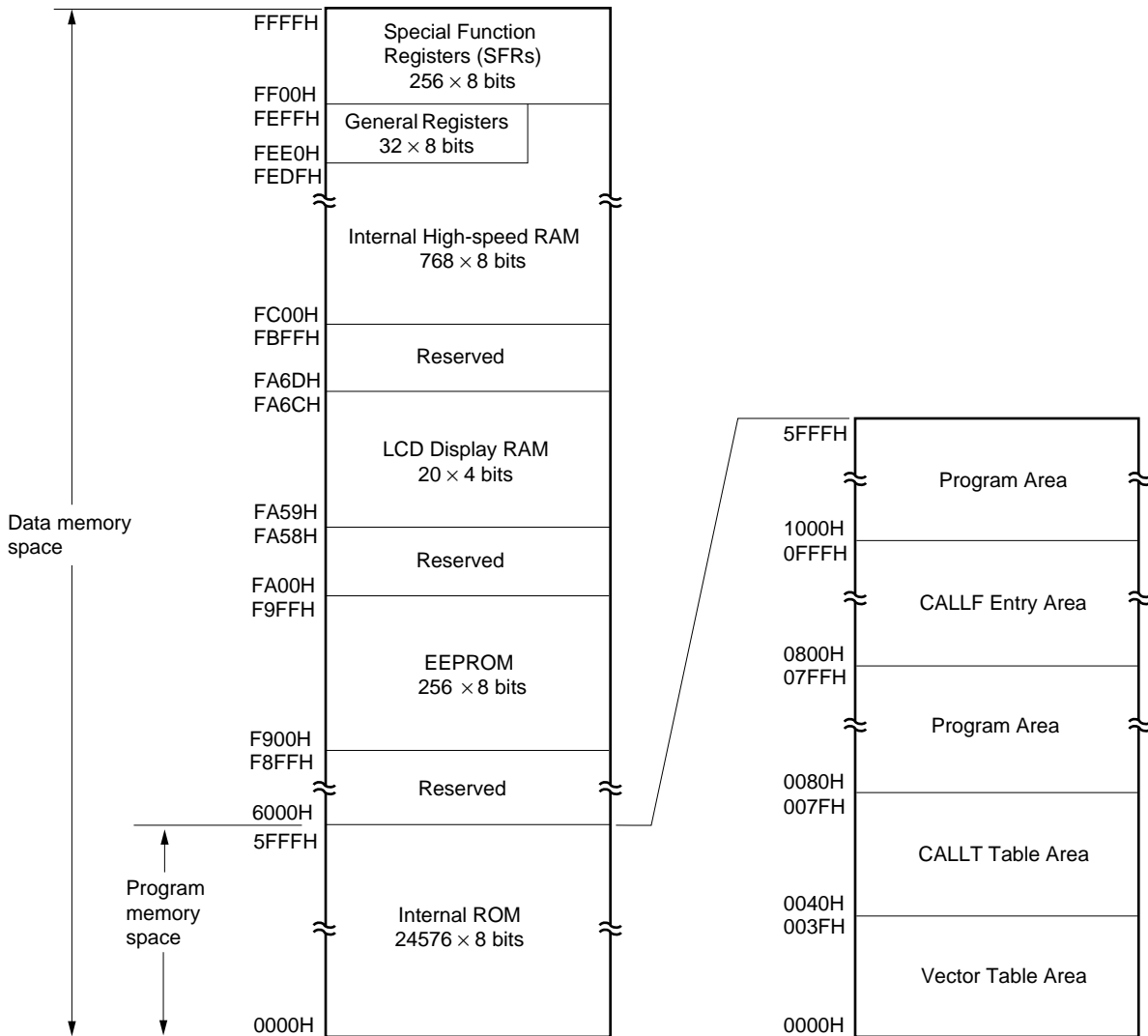
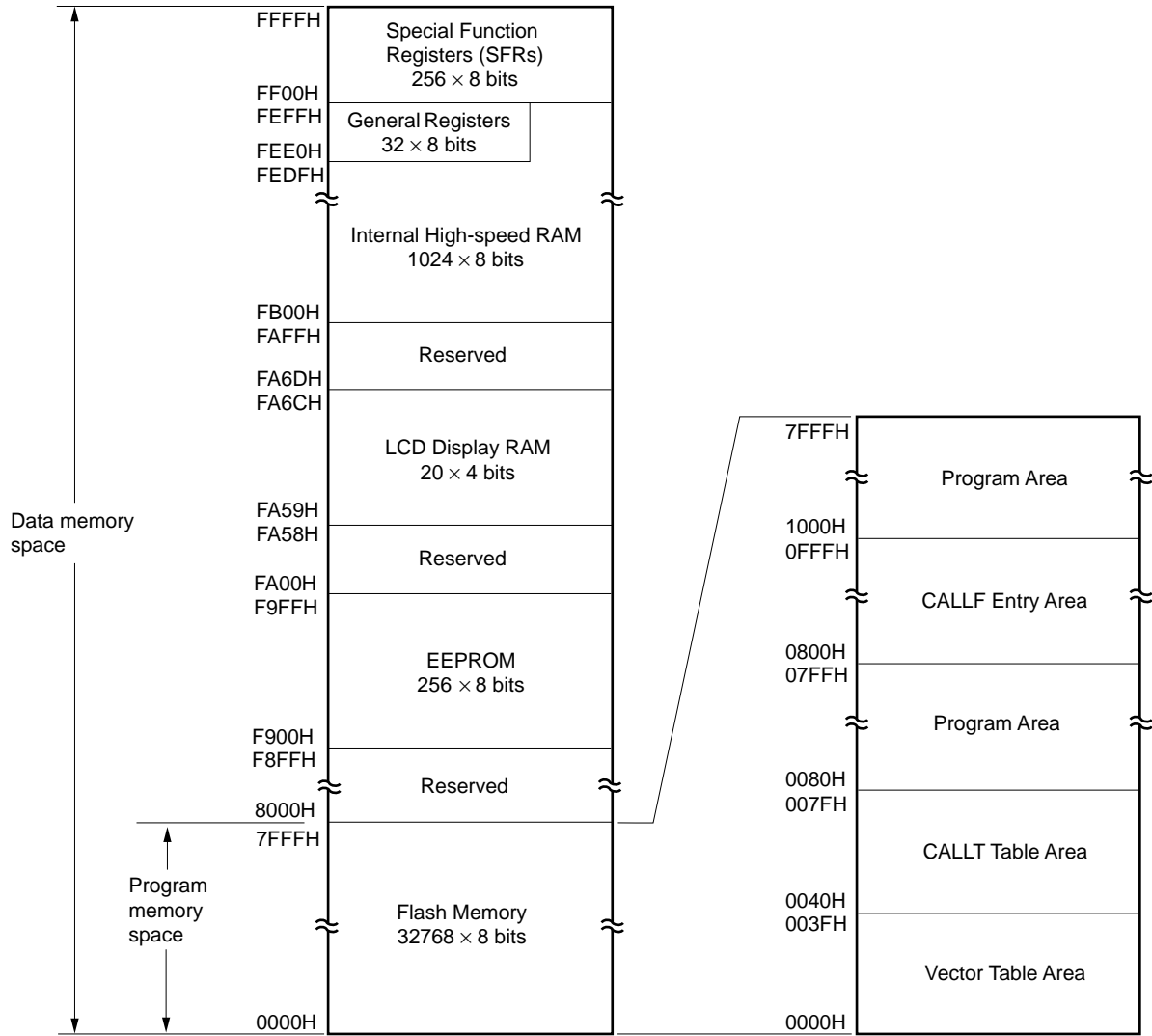

Figure 3-2. Memory Map (μ PD78F0974)



3.1.1 Internal program memory space

The internal program memory space contains the program and table data. Normally, it is addressed with the program counter (PC).

The μ PD780973 Subseries incorporate internal ROM (or flash memory), as listed below.

Table 3-1. Internal Memory Capacity

Part Number	Type	Capacity
μ PD780973(A)	Mask ROM	24576 \times 8 bits (0000H to 5FFFH)
μ PD78F0974	Flash Memory	32768 \times 8 bits (0000H to 7FFFH)

The following three areas are allocated to the program memory space.

(1) Vector table area

The 64-byte area 0000H to 003FH is reserved as a vector table area. This area stores program start addresses to which execution branches when the $\overline{\text{RESET}}$ signal is input or when an interrupt request is generated. Of a 16-bit address, the lower 8 bits are stored at an even address and the higher 8 bits are stored at an odd address.

Table 3-2. Vector Table

Vector Table Address	Interrupt Source
0000H	$\overline{\text{RESET}}$ input
0004H	INTWDT
0006H	INTAD
0008H	INTOVF
000AH	INTTM00
000CH	INTTM01
000EH	INTTM02
0010H	INTP0
0012H	INTP1
0014H	INTP2
0016H	INTCS10
0018H	INTSER
001AH	INTSR
001CH	INTST
001EH	INTTM1
0020H	INTTM2
0022H	INTTM3
0024H	INTWE
0026H	INTWI
0028H	INTWT
003EH	BRK

(2) CALLT instruction table area

The 64-byte area 0040H to 007FH can store the subroutine entry address of a 1-byte call instruction (CALLT).

(3) CALLF instruction entry area

The area 0800H to 0FFFH can perform a direct subroutine call with a 2-byte call instruction (CALLF).

3.1.2 Internal data memory space

The μ PD780973 Subseries have the following RAM.

(1) Internal high-speed RAM

Table 3-3. Internal High-Speed RAM Capacity

Product	Internal High-Speed RAM
μ PD780973(A)	768 \times 8 bits (FC00H to FEFH)
μ PD78F0974	1024 \times 8 bits (FB00H to FEFH)

The 32-byte area FEE0H to FEFH is allocated with four general-purpose register banks composed of eight 8-bit registers.

The internal high-speed RAM can be used as stack memory.

(2) LCD display RAM

An LCD display RAM is allocated to a 20 \times 4 bits area consisting of FA59H to FA6CH. The LCD display RAM can also be used as a normal RAM.

3.1.3 Special function register (SFR) area

An on-chip peripheral hardware special-function register (SFR) is allocated in the area FF00H to FFFFH (Refer to **3.2.3 Special function registers (SFRs) Table 3-5 Special Function Register List**).

Caution Do not access addresses where the SFR is not assigned.

3.1.4 Data memory addressing

Addressing refers to the method of specifying the address of the instruction to be executed next or the address of the register or memory relevant to the execution of instructions.

The address of an instruction to be executed next is addressed by the program counter (PC) (for details, see **3.3 Instruction Address Addressing**).

Several addressing modes are provided for addressing the memory relevant to the execution of instructions for the μ PD780973 Subseries, based on operability and other considerations. For areas containing data memory in particular, special addressing methods designed for the functions of special function registers (SFR) and general-purpose registers are available for use. Data memory addressing is illustrated in Figures 3-3 and 3-4. For the details of each addressing mode, see **3.4 Operand Address Addressing**.

Figure 3-3. Data Memory Addressing (μ PD780973(A))

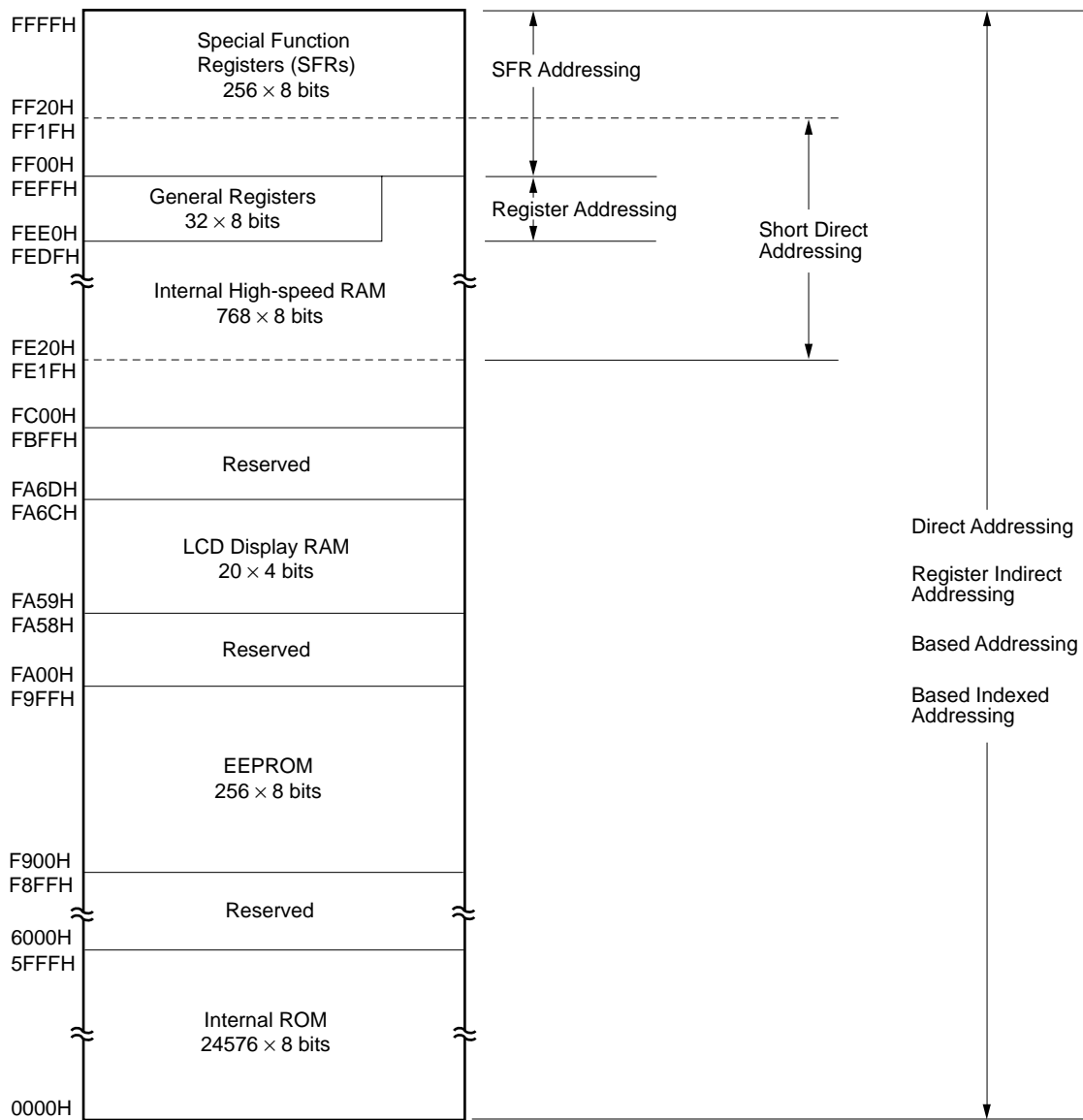
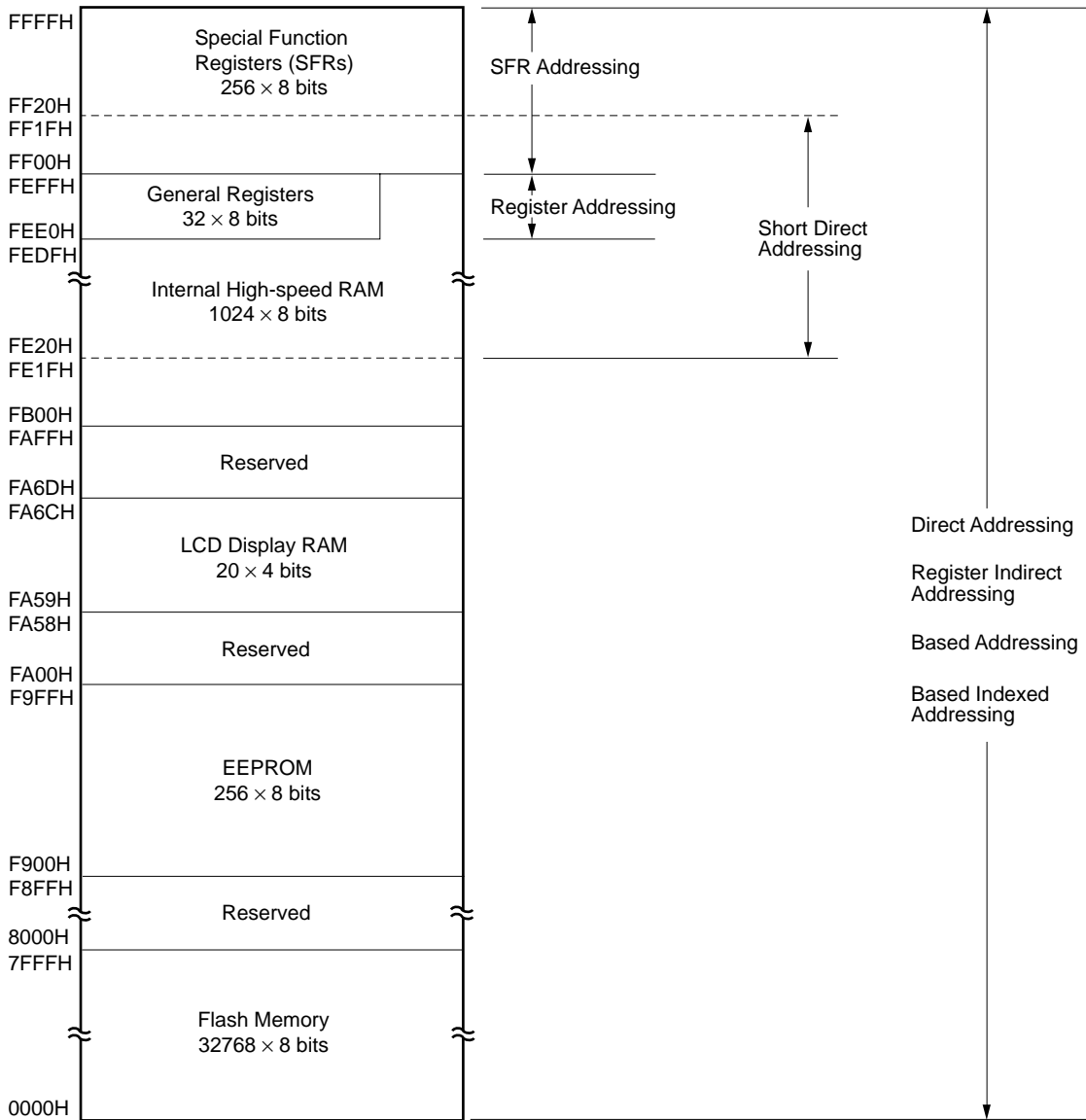

Figure 3-4. Data Memory Addressing (μ PD78F0974)



3.2 Processor Registers

The μ PD780973 Subseries incorporate the following processor registers.

3.2.1 Control registers

The control registers control the program sequence, status, and stack memory. The control registers consist of a program counter, a program status word, and a stack pointer.

(1) Program counter (PC)

The program counter is a 16-bit register which holds the address information of the next program to be executed. In normal operation, the PC is automatically incremented according to the number of bytes of the instruction to be fetched. When a branch instruction is executed, immediate data and register contents are set.

$\overline{\text{RESET}}$ input sets the reset vector table values at addresses 0000H and 0001H to the program counter.

Figure 3-5. Program Counter Configuration

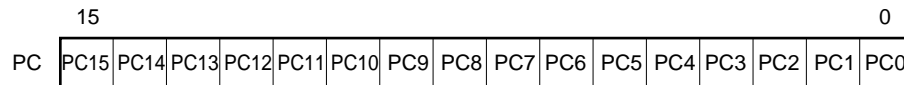

(2) Program status word (PSW)

The program status word is an 8-bit register consisting of various flags to be set/reset by instruction execution. Program status word contents are automatically stacked upon interrupt request generation or PUSH PSW instruction execution and are automatically reset upon execution of the RETB, RETI and POP PSW instructions.

$\overline{\text{RESET}}$ input sets the PSW to 02H.

Figure 3-6. Program Status Word Configuration

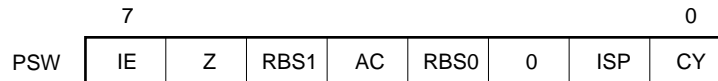

(a) Interrupt enable flag (IE)

This flag controls the interrupt request acknowledge operations of the CPU. When 0, the IE is set to DI, and only non-maskable interrupt request becomes acknowledgeable. Other interrupt requests are all disabled. When 1, the IE is set to EI and interrupt request acknowledge enable is controlled with an in-service priority flag (ISP), an interrupt mask flag for various interrupt sources and a priority specify flag. The IE is reset (to 0) upon DI instruction execution or interrupt acknowledgement and is set (to 1) upon EI instruction execution.

(b) Zero flag (Z)

When the operation result is zero, this flag is set (to 1). It is reset (to 0) in all other cases.

(c) Register bank select flags (RBS0 and RBS1)

These are 2-bit flags to select one of the four register banks. In these flags, the 2-bit information which indicates the register bank selected by SEL RBn instruction execution is stored.

(d) Auxiliary carry flag (AC)

If the operation result has a carry from bit 3 or a borrow at bit 3, this flag is set (to 1). It is reset (to 0) in all other cases.

(e) In-service priority flag (ISP)

This flag manages the priority of acknowledgeable maskable vectored interrupts. When this flag is 0, low-level vectored interrupts specified with a priority specify flag register (PR0L, PR0H, PR1L) (refer to **19.3 (3) Priority specify flag registers (PR0L, PR0H, PR1L)**) are disabled for acknowledgement. Actual acknowledgement is controlled with the interrupt enable flag (IE).

(f) Carry flag (CY)

This flag stores overflow and underflow upon add/subtract instruction execution. It stores the shift-out value upon rotate instruction execution and functions as a bit accumulator during bit manipulation instruction execution.

(3) Stack pointer (SP)

This is a 16-bit register to hold the start address of the memory stack area. Only the internal high-speed RAM area can be set as the stack area. The internal high-speed RAM areas of each product are as follows.

Table 3-4. Internal High-Speed RAM Area

Product	Internal High-Speed RAM Area
μPD780973(A)	FC00H to FEFFH
μPD78F0974	FB00H to FEFFH

Figure 3-7. Stack Pointer Configuration

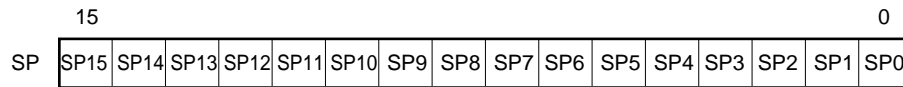

The SP is decremented prior to write (save) to the stack memory and is incremented after read (restore) from the stack memory.

Each stack operation saves/restores data as shown in Figures 3-8 and 3-9.

Caution Since $\overline{\text{RESET}}$ input makes SP contents undefined, be sure to initialize the SP before instruction execution.

Figure 3-8. Data to be Saved to Stack Memory

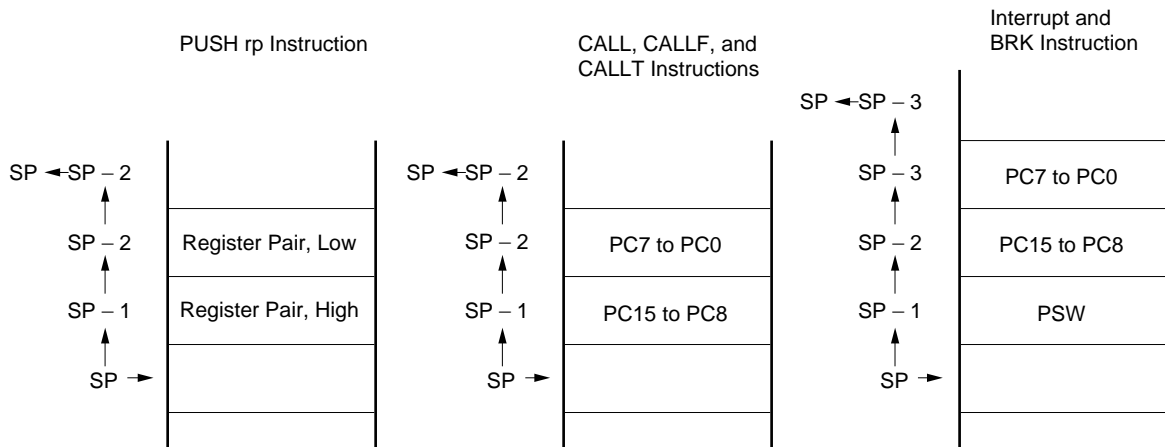
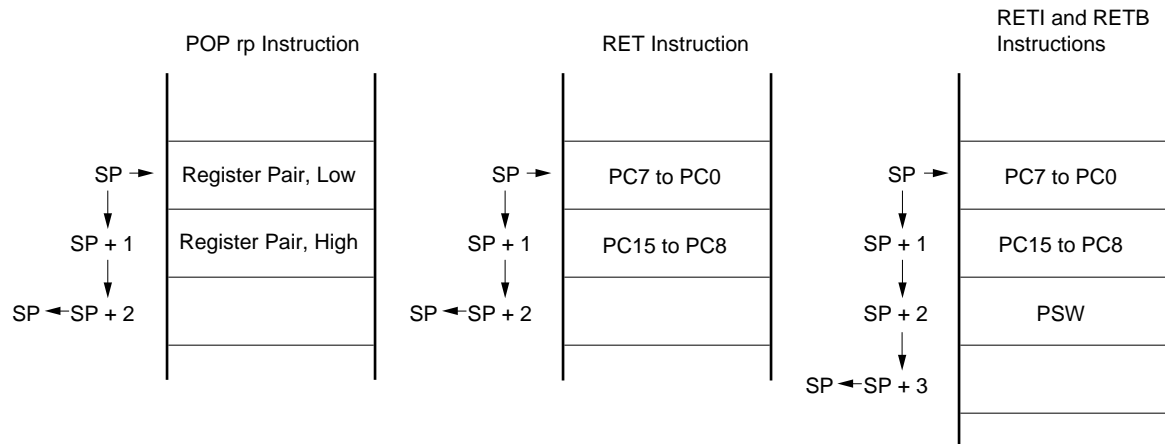

Figure 3-9. Data to be Reset from Stack Memory



3.2.2 General registers

General registers are mapped at particular addresses (FEE0H to FEFFH) of the data memory. Four banks of general registers, each consisting of eight 8-bit registers (X, A, C, B, E, D, L and H) are available.

Each register can also be used as an 8-bit register. Two 8-bit registers can be used in pairs as a 16-bit register (AX, BC, DE and HL).

They can be described in terms of function names (X, A, C, B, E, D, L, H, AX, BC, DE and HL) and absolute names (R0 to R7 and RP0 to RP3).

Register banks to be used for instruction execution are set with the CPU control instruction (SEL RBn). Because of the 4-register bank configuration, an efficient program can be created by switching between a register for normal processing and a register for interrupt processing for each bank.

Figure 3-10. General Register Configuration

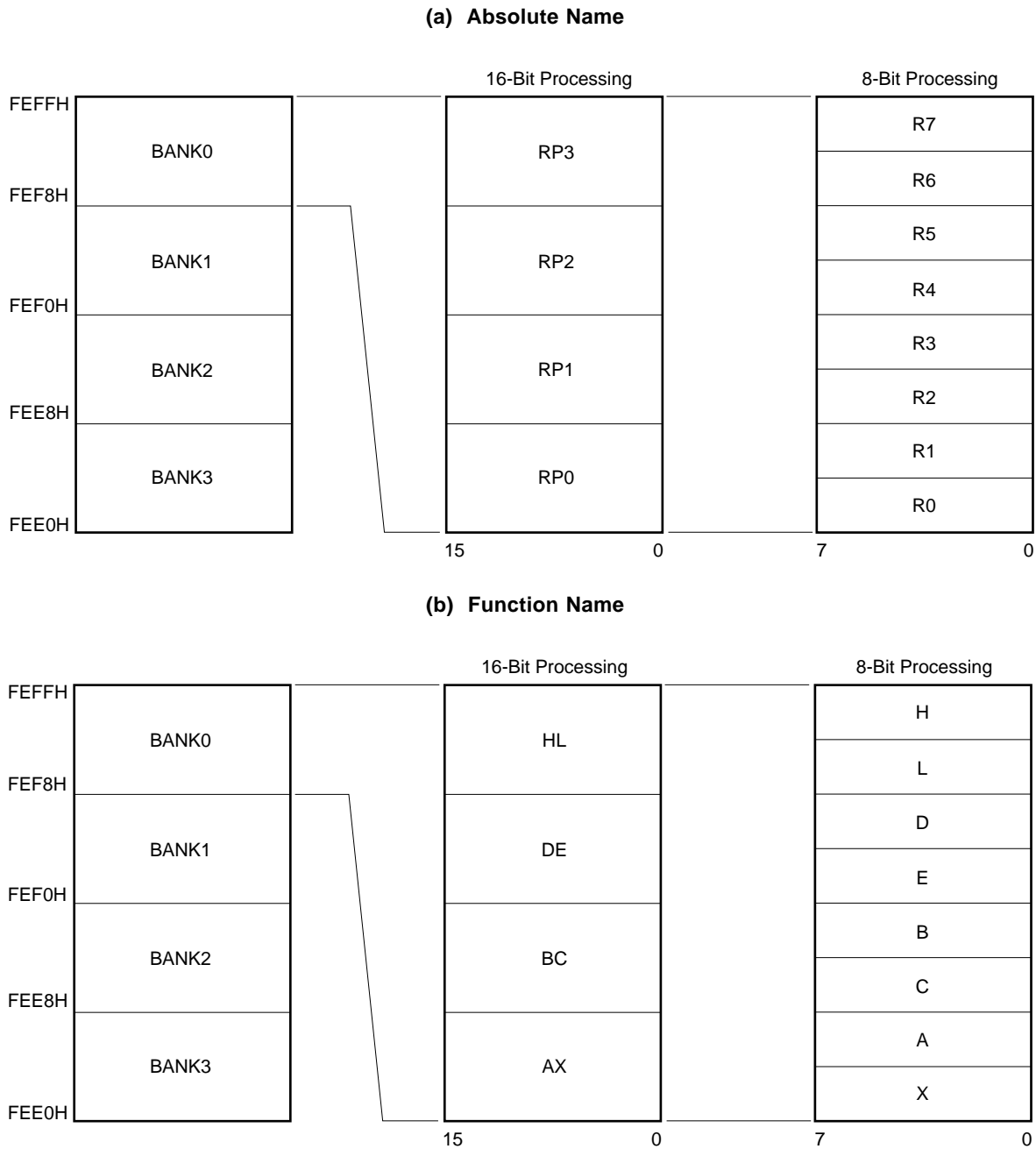

3.2.3 Special function registers (SFRs)

Unlike the general registers, these registers have special functions.

They are allocated in the FF00H to FFFFH area.

The special-function registers can be manipulated like the general registers, with the operation, transfer and bit manipulation instructions. The bit units (1, 8, or 16 bits) for the manipulation vary for each register.

Each manipulation bit unit can be specified as follows.

- 1-bit manipulation
Describe the symbol reserved with assembler for the 1-bit manipulation instruction operand (sfr.bit).
This manipulation can also be specified with an address.
- 8-bit manipulation
Describe the symbol reserved with assembler for the 8-bit manipulation instruction operand (sfr).
This manipulation can also be specified with an address.
- 16-bit manipulation
Describe the symbol reserved with assembler for the 16-bit manipulation instruction operand (sfrp).
When addressing an address, describe an even address.

Table 3-5 gives a list of special-function registers. The meaning of items in the table is as follows.

- Symbol
Symbol indicating the address of a special function register. It is a reserved word in the RA78K/0, and is defined via the header file "sfrbit.h" in the CC78K/0. It can be described as an instruction operand when the RA78K/0 and ID78K0 are used.
- R/W
Indicates whether the corresponding special-function register can be read or written.
R/W : Read/write enable
R : Read only
W : Write only
- Manipulatable bit units
Indicates the manipulatable bit unit (1, 8, or 16). "—" indicates a bit unit for which manipulation is not possible.
- After reset
Indicates each register status upon $\overline{\text{RESET}}$ input.

Table 3-5. Special Function Register List (1/3)

Address	Special-Function Register (SFR) Name	Symbol	R/W	Manipulatable Bit Unit			After Reset		
				1 bit	8 bits	16 bits			
FF00H	Port 0	P0	R/W	○	○	—	00H		
FF01H	Port 1	P1	R	—	○	—			
FF02H	Port 2	P2	R/W Note	○	○	—			
FF03H	Port 3	P3		○	○	—			
FF04H	Port 4	P4	R/W	○	○	—			
FF05H	Port 5	P5		○	○	—			
FF06H	Port 6	P6		○	○	—			
FF08H	Port 8	P8		○	○	—			
FF09H	Port 9	P9		○	○	—			
FF0AH	8-bit compare register 1	CR1		—	○	—			
FF0BH	8-bit compare register 2	CR2	—	○	—				
FF0CH	8-bit compare register 3	CR3	—	○	—				
FF0DH	8-bit counter 1	TM1	R	—	○	—			
FF0EH	8-bit counter 2	TM2		—	○	—			
FF0FH	8-bit counter 3	TM3		—	○	—			
FF10H	Capture register 00	CR00	R	—	—	○	0000H		
FF11H				—	—	○			
FF12H	Capture register 01	CR01		—	—	○			
FF13H				—	—	○			
FF14H	Capture register 02	CR02		—	—	○			
FF15H				—	—	○			
FF16H	16-bit timer register	TM0		—	—	○			
FF17H				—	—	○			
FF18H	Serial I/O shift register	SIO		R/W	—	○		—	00H
FF19H	Transmit shift register	TXS		W	—	○		—	FFH
	Receive buffer register	RXB		R	—	○		—	FFH
FF1BH	A/D conversion result register	ADCR1		R	—	○		—	00H

Note When PM2 and PM3 are set to 00H, read operation is enabled. Moreover, when PM2 and PM3 are set to FFH, these ports go into a high-impedance state.

Table 3-5. Special Function Register List (2/3)

Address	Special-Function Register (SFR) Name	Symbol	R/W	Manipulatable Bit Unit			After Reset	
				1 bit	8 bits	16 bits		
FF20H	Port mode register 0	PM0	R/W	○	○	—	FFH	
FF22H	Port mode register 2	PM2		○	○	—		
FF23H	Port mode register 3	PM3		○	○	—		
FF24H	Port mode register 4	PM4		○	○	—		
FF25H	Port mode register 5	PM5		○	○	—		
FF26H	Port mode register 6	PM6		○	○	—		
FF28H	Port mode register 8	PM8		○	○	—		
FF29H	Port mode register 9	PM9		○	○	—		
FF30H	Pull-up resistor option register	PU0		R/W	○	○		—
FF40H	Clock output selection register	CKS	○		○	—		
FF41H	Watch timer mode control register	WTM	○		○	—		
FF42H	Watchdog timer clock select register	WDCS	○		○	—		
FF48H	External interrupt rising edge enable register	EGP	○		○	—		
FF49H	External interrupt falling edge enable register	EGN	○		○	—		
FF4AH	LCD timer control register	LCDTM	W		○	○	—	
FF61H	Compare register (sin side)	MCMP10	R/W		○	○	—	
FF62H	Compare register (cos side)	MCMP11			○	○	—	
FF63H	Compare register (sin side)	MCMP20			○	○	—	
FF64H	Compare register (cos side)	MCMP21			○	○	—	
FF65H	Compare register (sin side)	MCMP30			○	○	—	
FF66H	Compare register (cos side)	MCMP31			○	○	—	
FF67H	Compare register (sin side)	MCMP40			○	○	—	
FF68H	Compare register (cos side)	MCMP41			○	○	—	
FF69H	Timer mode control register	MCNTC		○	○	—		
FF6AH	Port mode control register	PMC		○	○	—		
FF6BH	Compare control register 1	MCMPC1		○	○	—		
FF6CH	Compare control register 2	MCMPC2		○	○	—		
FF6DH	Compare control register 3	MCMPC3		○	○	—		
FF6EH	Compare control register 4	MCMPC4		○	○	—		
FF70H	Prescaler mode register	PRM0	R/W	○	○	—		
FF71H	Capture pulse control register	CRC0		○	○	—		
FF72H	16-bit timer mode control register	TMC0		○	○	—		
FF73H	Timer clock select register 1	TCL1		—	○	—		
FF74H	Timer clock select register 2	TCL2		—	○	—		
FF75H	Timer clock select register 3	TCL3		—	○	—		

Table 3-5. Special Function Register List (3/3)

Address	Special-Function Register (SFR) Name	Symbol	R/W	Manipulatable Bit Unit			After Reset	
				1 bit	8 bits	16 bits		
FF76H	8-bit timer mode control register 1	TMC1	R/W	○	○	—	04H	
FF77H	8-bit timer mode control register 2	TMC2		○	○	—		
FF78H	8-bit timer mode control register 3	TMC3		○	○	—		
FF80H	A/D converter mode register	ADM1		R	○	○	—	00H
FF81H	Analog input channel specification register	ADS1			○	○	—	
FF82H	Power-fail compare mode register	PFM			○	○	—	
FF83H	Power-fail compare threshold value register	PFT			○	○	—	
FF84H	Serial operation mode register	CSIM			○	○	—	
FF85H	Asynchronous serial interface mode register	ASIM			○	○	—	
FF86H	Asynchronous serial interface status register	ASIS	—		○	—		
FF87H	Baud rate generator control register	BRGC	R/W		—	○	—	
FF89H	D/A converter mode register	DAM1	W		○	○	—	
FF90H	EEPROM write control register	EEWC	R/W	○	○	—		
FF94H	Sound generator control register	SGCR		○	○	—		
FF95H	Sound generator buzzer control register	SGBR		○	○	—		
FF96H	Sound generator amplitude register	SGAM		○	○	—		
★ FFA0H	Oscillator mode register Note 1	OSCM		○	○	—		
FFB0H	LCD display mode register	LCDM		○	○	—		
FFB2H	LCD display control register	LCDC		○	○	—		
FFE0H	Interrupt request flag register 0L	IF0		IF0L	○	○		○
FFE1H	Interrupt request flag register 0H			IF0H	○	○		
FFE2H	Interrupt request flag register 1L	IF1L			○	○		—
FFE4H	Interrupt mask flag register 0L	MK0	MK0L	○	○	○	FFH	
FFE5H	Interrupt mask flag register 0H		MK0H	○	○			
FFE6H	Interrupt mask flag register 1L	MK1L		○	○	—		
FFE8H	Priority specify flag register 0L	PR0	PR0L	○	○	○		
FFE9H	Priority specify flag register 0H		PR0H	○	○			
FFEAH	Priority specify flag register 1L	PR1L		○	○	—		
FFF0H	Memory size switching register	IMS		—	○	—	CFH Note 2	
FFF9H	Watchdog timer mode register	WDTM		○	○	—	00H	
FFFAH	Oscillation stabilization time select register	OSTS		—	○	—	04H	
FFFBH	Processor clock control register	PCC		○	○	—		

Notes 1. μ PD780973(A) only

2. The initial value of this register is CFH. Set the following value to this register of each model.

μ PD780973(A): 06H

μ PD78F0974 (to set the same memory map as μ PD780973(A)): 06H

3.3 Instruction Address Addressing

An instruction address is determined by program counter (PC) contents and is normally incremented (+1 for each byte) automatically according to the number of bytes of an instruction to be fetched each time another instruction is executed. When a branch instruction is executed, the branch destination information is set to the PC and branched by the following addressing (For details of instructions, refer to **78K/0 SERIES USER'S MANUAL Instructions (U12326E)**).

3.3.1 Relative addressing

[Function]

The value obtained by adding 8-bit immediate data (displacement value: *jdisp8*) of an instruction code to the start address of the following instruction is transferred to the program counter (PC) and branched. The displacement value is treated as signed two's complement data (−128 to +127) and bit 7 becomes a sign bit. In other words, relative addressing consists in relative branching from the start address of the following instruction to the −128 to +127 range.

This function is carried out when the BR \$addr16 instruction or a conditional branch instruction is executed.

[Operation]

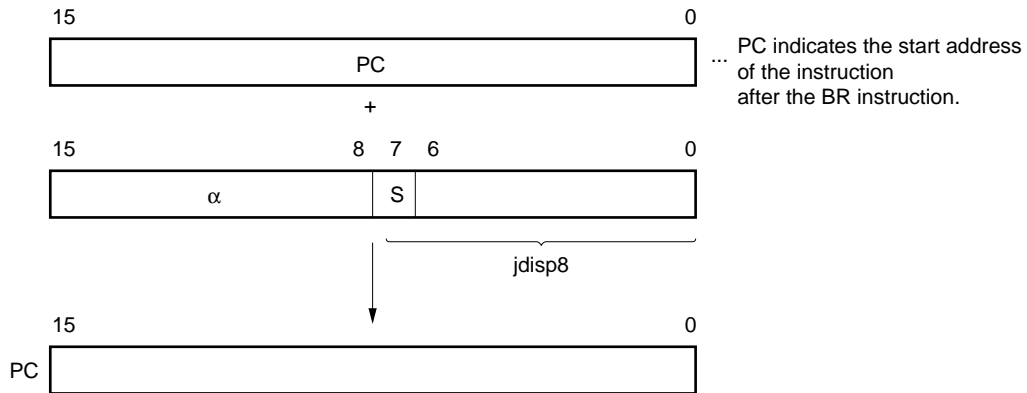

When S = 0, all bits of α are 0.
 When S = 1, all bits of α are 1.

3.3.2 Immediate addressing

[Function]

Immediate data in the instruction word is transferred to the program counter (PC) and branched. This function is carried out when the CALL !addr16 or BR !addr16 or CALLF !addr11 instruction is executed. CALL !addr16 and BR !addr16 instructions can be branched to the entire memory space. The CALLF !addr11 instruction is branched to the 0800H to 0FFFH area.

[Operation]

In the case of CALL !addr16 and BR !addr16 instructions

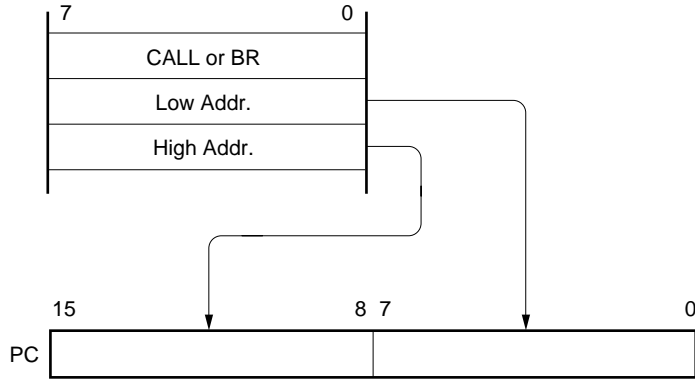

In the case of CALLF !addr11 instruction

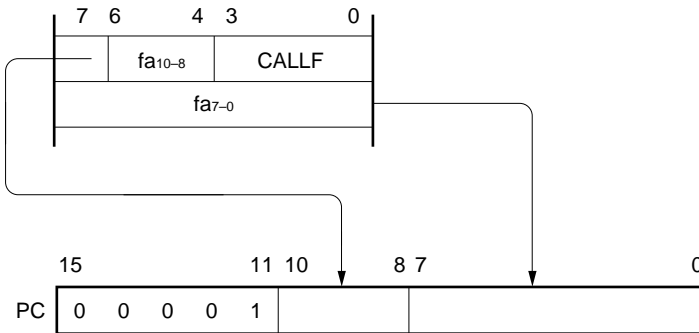

3.3.3 Table indirect addressing

[Function]

Table contents (branch destination address) of the particular location to be addressed by bits 1 to 5 of the immediate data of an operation code are transferred to the program counter (PC) and branched.

This function is carried out when the CALLT [addr5] instruction is executed.

This instruction references the address stored in the memory table from 40H to 7FH, and allows branching to the entire memory space.

[Operation]

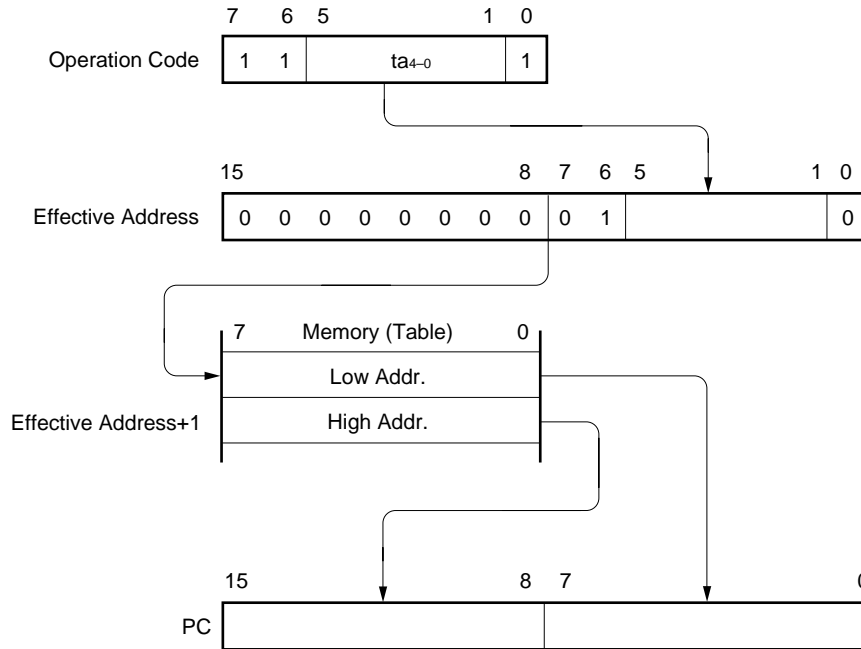

3.3.4 Register addressing

[Function]

Register pair (AX) contents to be specified with an instruction word are transferred to the program counter (PC) and branched.

This function is carried out when the BR AX instruction is executed.

[Operation]

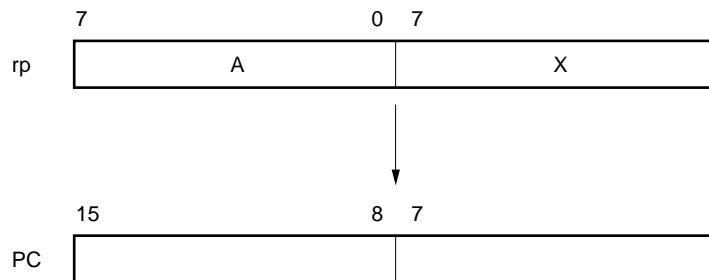

3.4 Operand Address Addressing

The following methods are available to specify the register and memory (addressing) which undergo manipulation during instruction execution.

3.4.1 Implied addressing

[Function]

The register which functions as an accumulator (A and AX) in the general register is automatically (implicitly) addressed.

Of the μ PD780973 Subseries instruction words, the following instructions employ implied addressing.

Instruction	Register to be Specified by Implied Addressing
MULU	Register A for multiplicand and register AX for product storage
DIVUW	Register AX for dividend and quotient storage
ADJBA/ADJBS	Register A for storage of numeric values subject to decimal adjustment
ROR4/ROL4	Register A for storage of digit data subject to digit rotation

[Operand format]

Because implied addressing can be automatically employed with an instruction, no particular operand format is necessary.

[Description example]

In the case of MULU X

With an 8-bit \times 8-bit multiply instruction, the product of A register and X register is stored in AX. In this example, the A and AX registers are specified by implied addressing.

3.4.2 Register addressing

[Function]

The general register to be specified is accessed as an operand with the register specify code (Rn and RPN) in an operation code and with the register bank select flags (RBS0 and RBS1).

Register addressing is carried out when an instruction with the following operand format is executed. When an 8-bit register is specified, one of the eight registers is specified with 3 bits in the operation code.

[Operand format]

Identifier	Description
r	X, A, C, B, E, D, L, H
rp	AX, BC, DE, HL

'r' and 'rp' can be described with function names (X, A, C, B, E, D, L, H, AX, BC, DE and HL) as well as absolute names (R0 to R7 and RP0 to RP3).

[Description example]

MOV A, C; when selecting C register as r

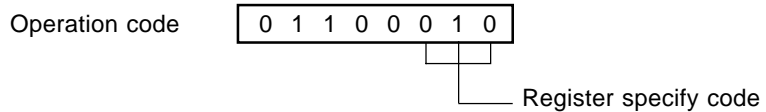

INCW DE; when selecting DE register pair as rp

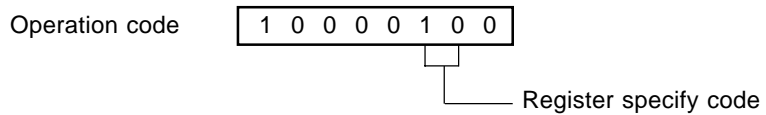

3.4.3 Direct addressing

[Function]

The memory to be manipulated is addressed with immediate data in an instruction word becoming an operand address.

[Operand format]

Identifier	Description
addr16	Label or 16-bit immediate data

[Description example]

MOV A, !0FE00H; when setting !addr16 to FE00H

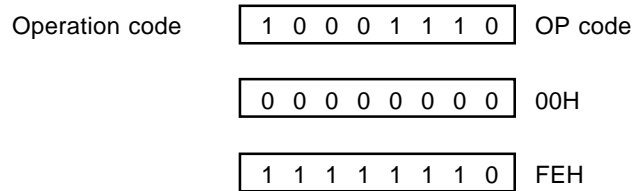

[Operation]

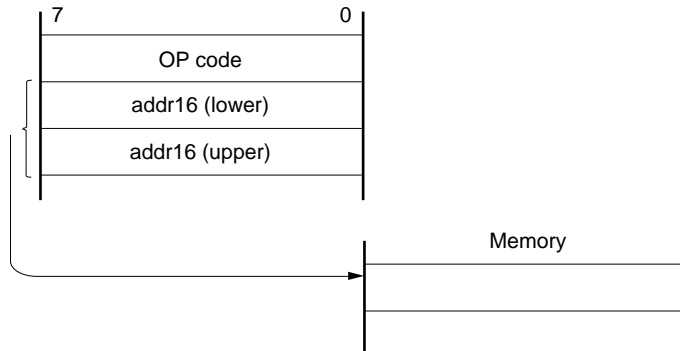

3.4.4 Short direct addressing

[Function]

The memory to be manipulated in the fixed space is directly addressed with 8-bit data in an instruction word. This addressing is applied to the 256-byte space FE20H to FF1FH. An internal high-speed RAM and a special-function register (SFR) are mapped at FE20H to FEFFH and FF00H to FF1FH, respectively.

If the SFR area (FF00H to FF1FH) where short direct addressing is applied, ports which are frequently accessed in a program and a compare register of the timer/event counter and a capture register of the timer/event counter are mapped and these SFRs can be manipulated with a small number of bytes and clocks.

When 8-bit immediate data is at 20H to FFH, bit 8 of an effective address is set to 0. When it is at 00H to 1FH, bit 8 is set to 1. Refer to **[Operation]** below.

[Operand format]

Identifier	Description
saddr	Label or FE20H to FF1FH immediate data
saddrp	Label or FE20H to FF1FH immediate data (even address only)

[Description example]

MOV 0FE30H, #50H; when setting saddr to FE30H and immediate data to 50H

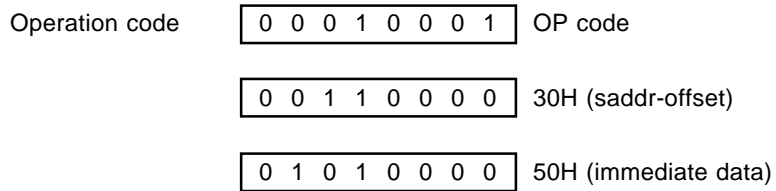

[Operation]

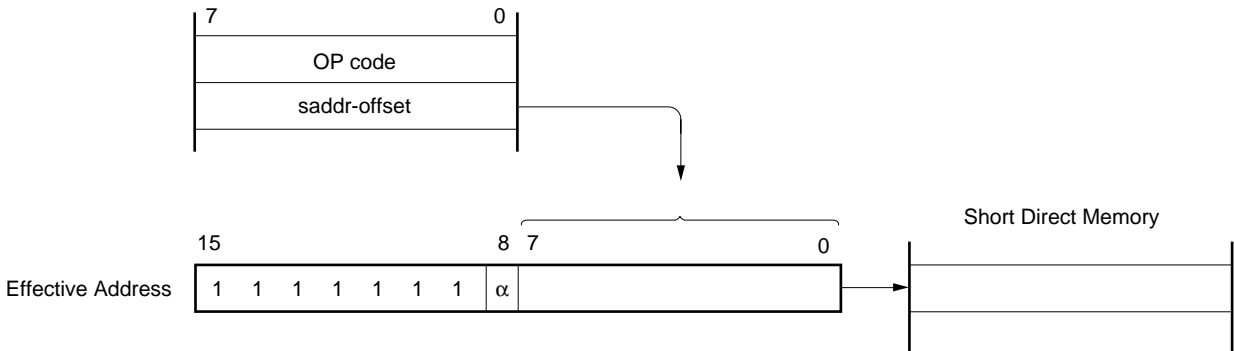

When 8-bit immediate data is 20H to FFH, $\alpha = 0$

When 8-bit immediate data is 00H to 1FH, $\alpha = 1$

3.4.5 Special-function register (SFR) addressing

[Function]

The memory-mapped special-function register (SFR) is addressed with 8-bit immediate data in an instruction word.

This addressing is applied to the 240-byte spaces FF00H to FFCFH and FFE0H to FFFFH. However, the SFR mapped at FF00H to FF1FH can be accessed with short direct addressing.

[Operand format]

Identifier	Description
sfr	Special-function register name
sfrp	16-bit manipulatable special-function register name (even address only)

[Description example]

MOV PM0, A; when selecting PM0 (FF20H) as sfr

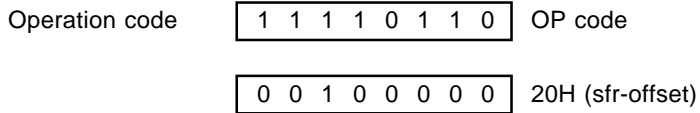

[Operation]

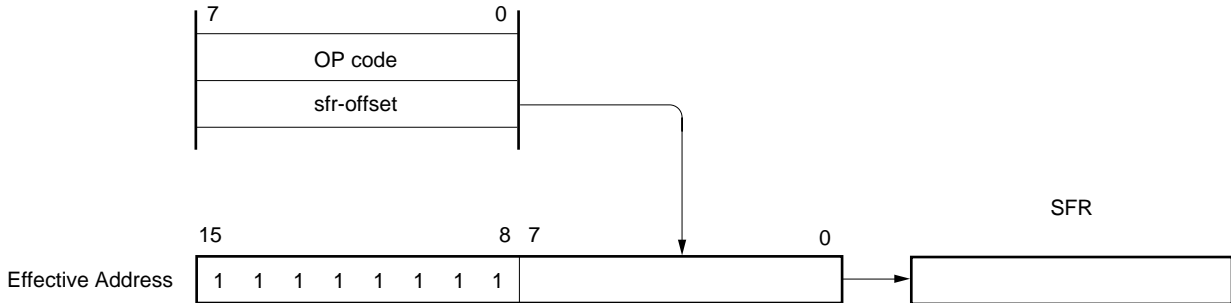

3.4.6 Register indirect addressing

[Function]

This addressing is to address a memory area to be manipulated by using as an operand address the contents of a register pair specified by the register bank select flags (RBS0 and RBS1) and the register pair specification code in the operation code. This addressing can be carried out for all the memory spaces.

[Operand format]

Identifier	Description
—	[DE], [HL]

[Description example]

MOV A, [DE]; when selecting [DE] as register pair

Operation code 1 0 0 0 0 1 0 1

[Operation]

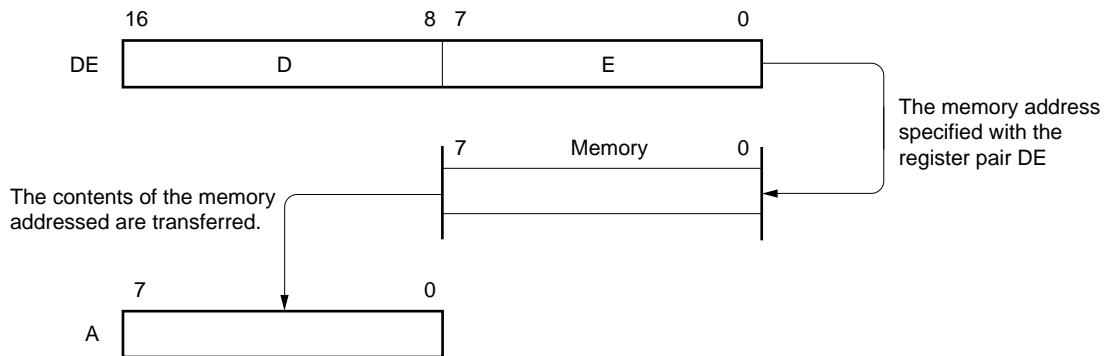

3.4.7 Based addressing

[Function]

8-bit immediate data is added as offset data to the contents of the base register, that is, the HL register pair in an instruction word of the register bank specified with the register bank select flags (RBS0 and RBS1) and the sum is used to address the memory. Addition is performed by expanding the offset data as a positive number to 16 bits. A carry from the 16th bit is ignored. This addressing can be carried out for all the memory spaces.

[Operand format]

Identifier	Description
—	[HL + byte]

[Description example]

MOV A, [HL + 10H]; when setting byte to 10H

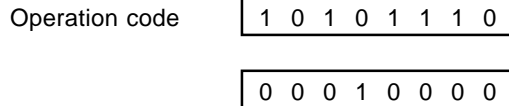

3.4.8 Based indexed addressing

[Function]

The B or C register contents specified in an instruction word are added to the contents of the base register, that is, the HL register pair in an instruction word of the register bank specified with the register bank select flags (RBS0 and RBS1) and the sum is used to address the memory. Addition is performed by expanding the B or C register contents as a positive number to 16 bits. A carry from the 16th bit is ignored. This addressing can be carried out for all the memory spaces.

[Operand format]

Identifier	Description
—	[HL + B], [HL + C]

[Description example]

In the case of MOV A, [HL + B]

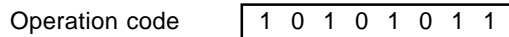

3.4.9 Stack addressing

[Function]

The stack area is indirectly addressed with the stack pointer (SP) contents.

This addressing method is automatically employed when the PUSH, POP, subroutine call and RETURN instructions are executed or the register is saved/reset upon generation of an interrupt request.

Stack addressing enables to address the internal high-speed RAM area only.

[Description example]

In the case of PUSH DE

Operation code

1 0 1 1 0 1 0 1

[MEMO]

CHAPTER 4 EEPROM

4.1 EEPROM Functions

The μ PD780973 Subseries products contain on-chip 256×8 -bit EEPROM (Electrically Erasable PROM) in addition to internal high-speed RAM, as data memory.

EEPROM differs from ordinary RAM in that its contents are saved even after power is cut off. Moreover, unlike EPROM, its contents can be erased electrically without using UV light. For this reason, it is suitable for applications where the setting values of the odometer and trip meter on the dash board are saved, etc.

EEPROM can be manipulated with 8-bit memory manipulation instructions.

The EEPROM contained on-chip in the μ PD780973 Subseries has the following features.

- (1) Written contents are saved even when the power is cut off.
- (2) Can be manipulated with 8-bit memory manipulation instructions in the same way as ordinary RAM.
- (3) Erasure and writing is performed in the time set with EWCS0 and EWCS1 (EEPROM write control register (EEWC) bits 4 and 5) (see Figure 4-2). Therefore, the write time control software load is reduced. Moreover, during writing, instructions other than instructions related to EEPROM writing and reading can also be executed.
 - Rewrite frequency for all chips : 1,000,000 times
 - Rewrite frequency per 1 byte : 100,000 times

★

Caution The values shown above are target values. These values are subject to change without notice, so please contact your NEC sales representative for the latest value before designing.

- (4) When write is completed, interrupt request signal (INTWE) is issued.
- (5) The write enabled/disabled status can be checked with EWST (EEPROM write control register (EEWC) bit 1).

4.2 EEPROM Configuration

EEPROM is composed of EEPROM itself and a control area.

The control area consists of the EEPROM write control register (EEWC) that controls EEPROM writing, and an area that generates an interrupt request signal (INTWE) upon detecting write termination.

Figure 4-1. EEPROM Block Diagram

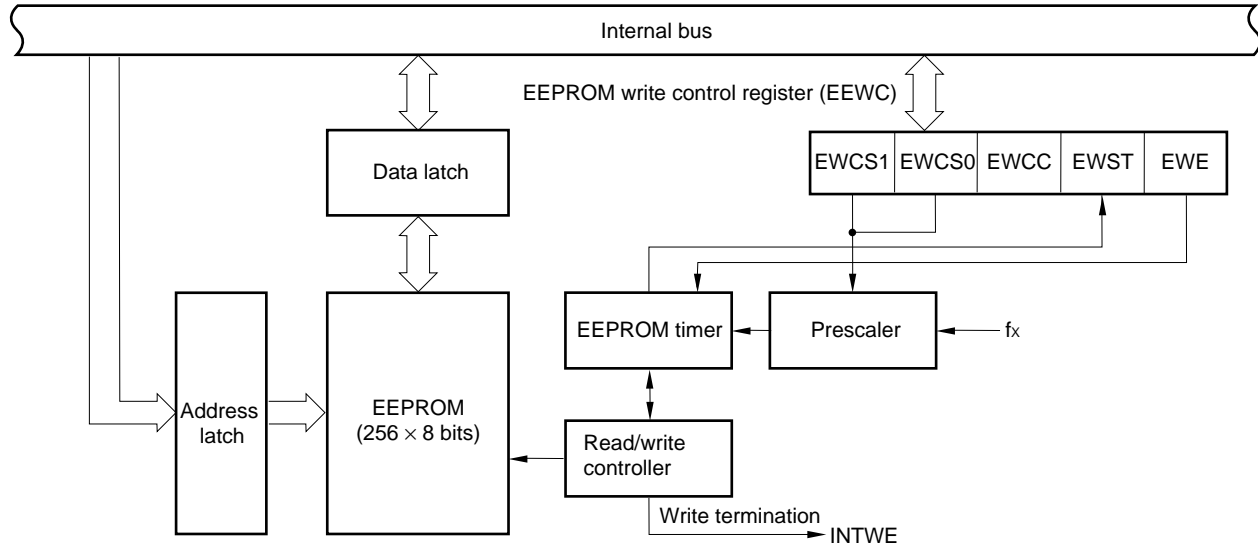

4.3 EEPROM Control Register

EEPROM is controlled with the EEPROM write control register (EEWC).
 EEWC is set with either a 1-bit or 8-bit memory manipulation instruction.
 $\overline{\text{RESET}}$ input sets EEWC to 00H.

Figure 4-2. EEPROM Write Control Register (EEWC) Format

Address: FF90H After Reset : 00H R/W

Symbol	7	6	5	4	3	2	1	0
EEWC	0	0	EWCS1	EWCS0	0	EWCC	EWST	EWE

EWCS1	EWCS0	EEPROM Write Time
0	0	$(2^{14} + 2^{10})/f_x$ Note 1
0	1	$(2^{15} + 2^{11})/f_x$ Note 2
Other than above		Setting prohibited

EWCC	EEPROM Operation Control
0	Operating mode
1	EEPROM stop

EWST	EEPROM Write Status
0	Not currently writing to EEPROM (EEPROM write/read is enabled. However, when EWE = 0, write is disabled)
1	Currently writing to EEPROM (EEPROM write/read is disabled)

EWE	EEPROM Write Operation Control
0	EEPROM write disabled
1	EEPROM write enabled

- Notes**
1. Set the main system clock frequency (f_x) in the range of 4 to 5.120 MHz.
 2. Set the main system clock frequency (f_x) in the range of 5.364 to 8.38 MHz.

- Cautions**
1. If the main system clock frequency is set in the range of $5.120 < f_x < 5.364$ MHz, the EEPROM cannot be used.
 2. When EWE is cleared (to 0) during EEPROM writing, writing is immediately interrupted. Data that was being written becomes undefined. Be sure to clear EWE before stopping the main system clock during the write period.
 3. After EWCC is cleared (to 0), set a wait time of 20 μs or more by software to read EEPROM contents.
 4. Be sure to check that EWST is 0 before performing EEPROM access.
 5. Bits 3, 6, and 7 must be set to 0.

4.4 EEPROM Reading

Reading of EEPROM data is performed with the following procedure.

- <1> Check that EWST (EEPROM write control register (EEWC) bit 1) is 0 (EEPROM writing is not in progress).
- <2> Execute read instruction.

- Cautions**
1. Before reading, be sure to check that EWST is 0. If an EEPROM read instruction is executed during EEPROM write, read values are undefined.
 2. If reading EEPROM contents immediately after changing EWCC (EEPROM write control register (EEWC) bit 2) from 1 to 0, set a wait time of at least 20 μ s by software. If no wait time is set, the correct values cannot be read.

Example: Insertion of NOP instructions to set wait time of 20 μ s or more.

```
CLR1 EWCC
NOP
NOP      } Insert NOP instructions to secure a wait time of 20  $\mu$ s or more.
MOV A,!0F800H
```

4.5 EEPROM Writing

Data writing to EEPROM is performed with the following procedure.

- <1> Check that EWST (EEPROM write control register (EEWC) bit 1) is 0 (EEPROM writing is not in progress).
- <2> Set the write time with EWCS0 and EWCS1 (EEWC bits 4 and 5).
- <3> Set EWE (EEWC bit 0) to 1 (EEPROM writing enabled).
- <4> Execute write instruction.

If performing several write operations in succession, perform the next write operation after the current write operation has been completed. The following methods can be used for write termination and time control.

(1) Method using write termination interrupt request (INTWE)

After writing 1 data, wait for generation of write termination interrupt request while processing other than write is performed. When write termination interrupt request is generated, start next write operation.

(2) Method using write status flag (EWST)

Poll EWST (EEPROM write control register (EEWC) bit 1), and wait for EWST to become 0. When EWST becomes 0, start the next write operation.

4.6 EEPROM Control-Related Interrupt

EEPROM write termination interrupt request (INTWE) is generated from EEPROM.

INTWE is an interrupt request generated upon termination of EEPROM writing.

This interrupt request is generated when the time set with EWCS0 and EWCS1 (EEPROM write control register (EEWC) bits 4 and 5) has elapsed.

When this interrupt request is generated, data writing to EEPROM is terminated, indicating that writing of the next data is enabled.

4.7 Cautions regarding EEPROM Writing

The following shows cautions of EEPROM write.

Before performing EEPROM write, be sure to read the following cautions.

- (1) Before writing, be sure to check that EWST (EEPROM write control register (EEWC) bit 1) is 0. If executing another write instructions during EEPROM writing, the instruction executed last will be ignored.
- (2) For write time, see Figure 4-2.
- (3) If performing several write operations in succession, be sure to wait until the current write operation is completed before starting the next one.
- (4) Even if the mode changes to HALT mode during EEPROM writing, writing is continued.
- (5) If the mode changes to STOP mode during EEPROM writing, the data being written becomes undefined. If this STOP mode is cancelled by interrupt request, a write termination interrupt request (INTWE) is generated after the STOP mode has been cancelled. If you want to set the STOP mode after normally terminating write processing, check that write processing has ended using any of the available methods (refer to **4.5 EEPROM Writing**), then set the STOP mode.
- (6) If you want to read the EEPROM contents immediately after changing EWCC (EEPROM write control register (EEWC) bit 2) from 1 to 0, set a wait time of 20 μ s or more by software. If no wait time is set, the data read will not be correct.

CHAPTER 5 PORT FUNCTIONS

5.1 Port Functions

The μ PD780973 Subseries are provided with five input port pins, sixteen output port pins, and thirty-five input/output port pins. Figure 5-1 shows the port configuration. Every port can be manipulated in 1-bit or 8-bit units controlled in various ways. Moreover, the port pins can also serve as I/O pins of the internal hardware.

Figure 5-1. Port Types

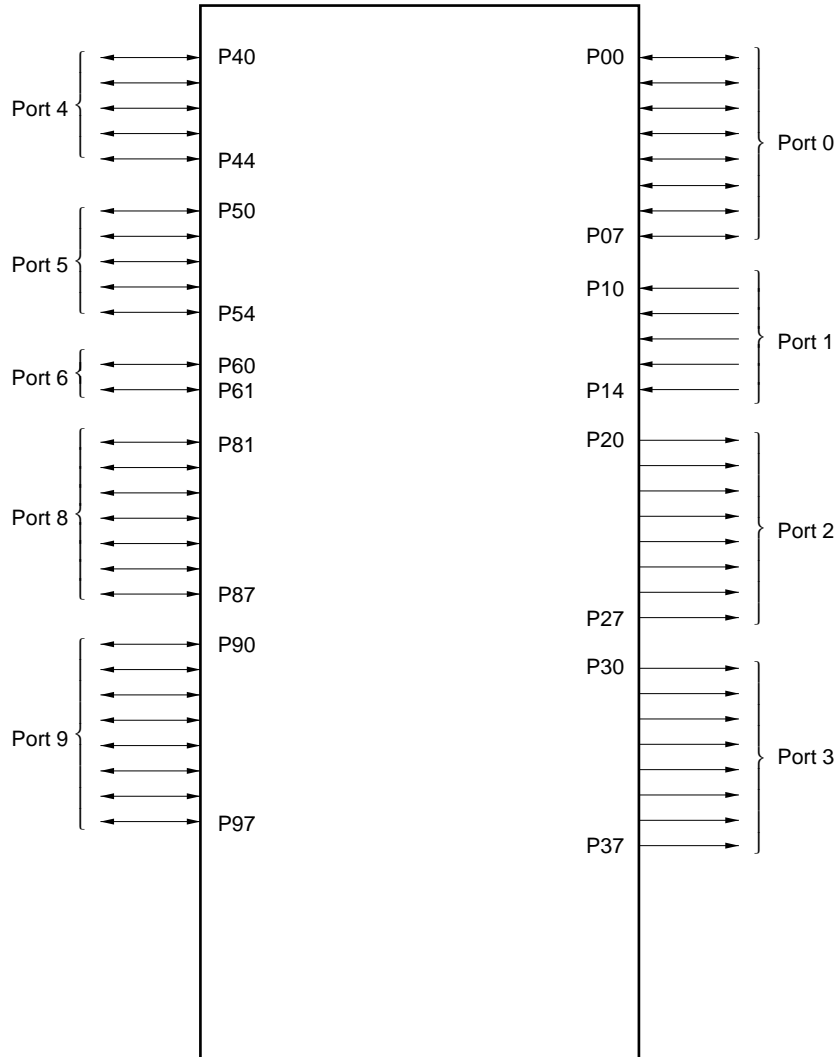

Table 5-1. Port Functions

Pin Name	Input/Output	Function	Alternate Function
P00 to P02	Input/Output	Port 0 8-bit input/output port. Input/output mode can be specified bit-wise. If used as an input port, an on-chip pull-up resistor can be used by software.	INTP0 to INTP2
P03 to P07			—
P10 to P14	Input	Port 1 5-bit input only port.	ANI0 to ANI4
P20 to P23	Output	Port 2 8-bit output only port.	SM11 to SM14
P24 to P27			SM21 to SM24
P30 to P33	Output	Port 3 8-bit output only port.	SM31 to SM34
P34 to P37			SM41 to SM44
P40 to P42	Input/Output	Port 4 5-bit input/output port. Input/output mode can be specified bit-wise.	TI00 to TI02
P43, P44			TIO2, TIO3
P50	Input/Output	Port 5 5-bit input/output port. Input/output mode can be specified bit-wise.	$\overline{\text{SCK}}$
P51			SO
P52			SI
P53			RxD
P54			TxD
P60	Input/Output	Port 6 2-bit input/output port. Input/output mode can be specified bit-wise.	PCL/SGOA
P61			SGO/SGOF
P81	Input/Output	Port 8 7-bit input/output port. Input/output mode can be specified bit-wise. Can be set in input/output port or segment output mode in 2-bit units by using LCD display control register (LCDC).	S19/TPO
P82 to P87			S18 to S13
P90 to P97	Input/Output	Port 9 8-bit input/output port. Input/output mode can be specified bit-wise. Can be set in input/output port or segment output mode in 2-bit units by using LCD display control register (LCDC).	S12 to S5

5.2 Port Configuration

A port consists of the following hardware:

Table 5-2. Port Configuration

Item	Configuration
Control register	Port mode register (PMm: m = 0, 2 to 6, 8, 9) Pull-up resistor option register (PU0)
Port	Total: 56 lines (5 inputs, 16 outputs, 35 inputs/outputs)
Pull-up resistor	Total: 8 (software specifiable: 8)

5.2.1 Port 0

Port 0 is an 8-bit input/output port with output latch. P00 to P07 pins can specify the input mode/output mode in 1-bit units with the port mode register 0 (PM0). When P00 to P07 pins are used as input ports, an on-chip pull-up resistor can be used to them in 1-bit units with a pull-up resistor option register (PU0).

Alternate functions include external interrupt request input.

$\overline{\text{RESET}}$ input sets port 0 to input mode.

Figure 5-2 shows a block diagram of port 0.

Caution Because port 0 also serves for external interrupt request input, when the port function output mode is specified and the output level is changed, the interrupt request flag is set. Thus, when the output mode is used, set the interrupt mask flag to 1.

Figure 5-2. P00 to P07 Block Diagram

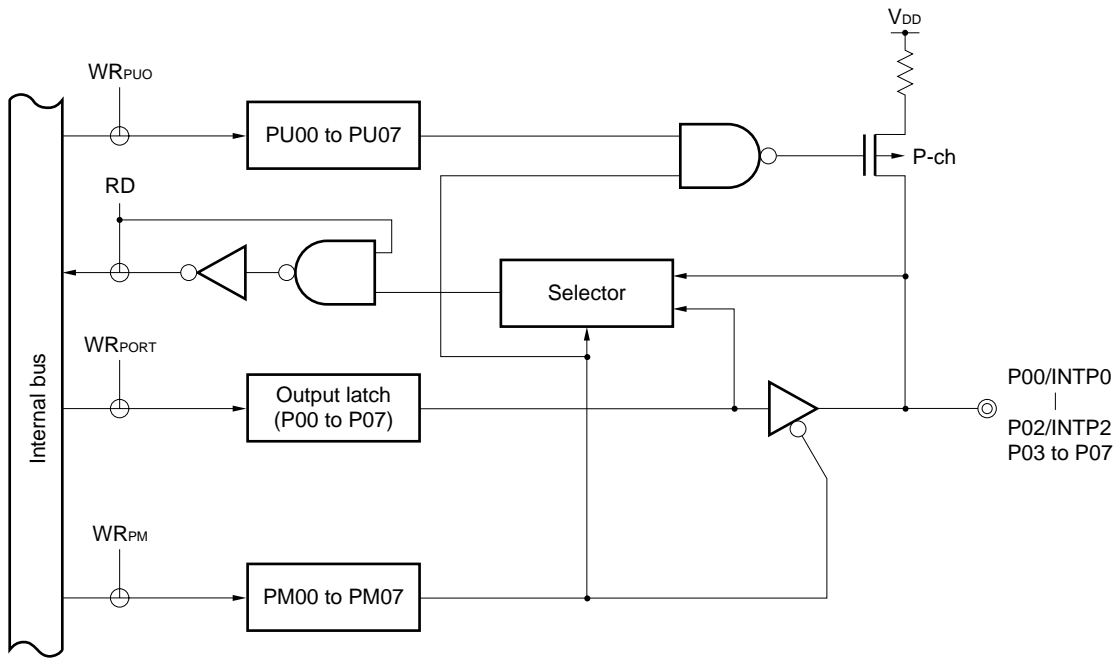

PU : Pull-up resistor option register
 PM : Port mode register
 RD : Port 0 read signal
 WR : Port 0 write signal

5.2.2 Port 1

Port 1 is a 5-bit input only port.
 Alternate functions include an A/D converter analog input.
 Figure 5-3 shows a block diagram of port 1.

Figure 5-3. P10 to P14 Block Diagram

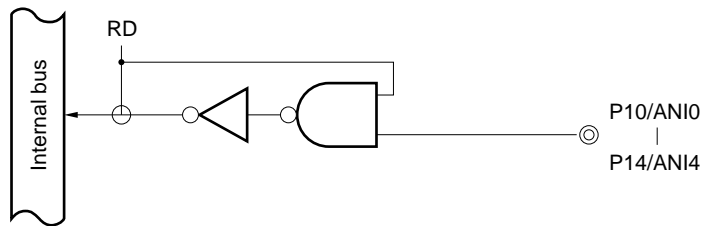

RD : Port 1 read signal

★ 5.2.3 Port 2

Port 2 is an 8-bit output only port with output latch. P20 to P27 pins go into a high-impedance state when the ENn of port mode control register (PMC) is set to 0 and the port mode register 2 (PM2) is set to 1.

Alternate functions include meter control PWM output.

$\overline{\text{RESET}}$ input sets port 2 to high-impedance state.

Figure 5-4 shows a block diagram of port 2.

Figure 5-4. P20 to P27 Block Diagram

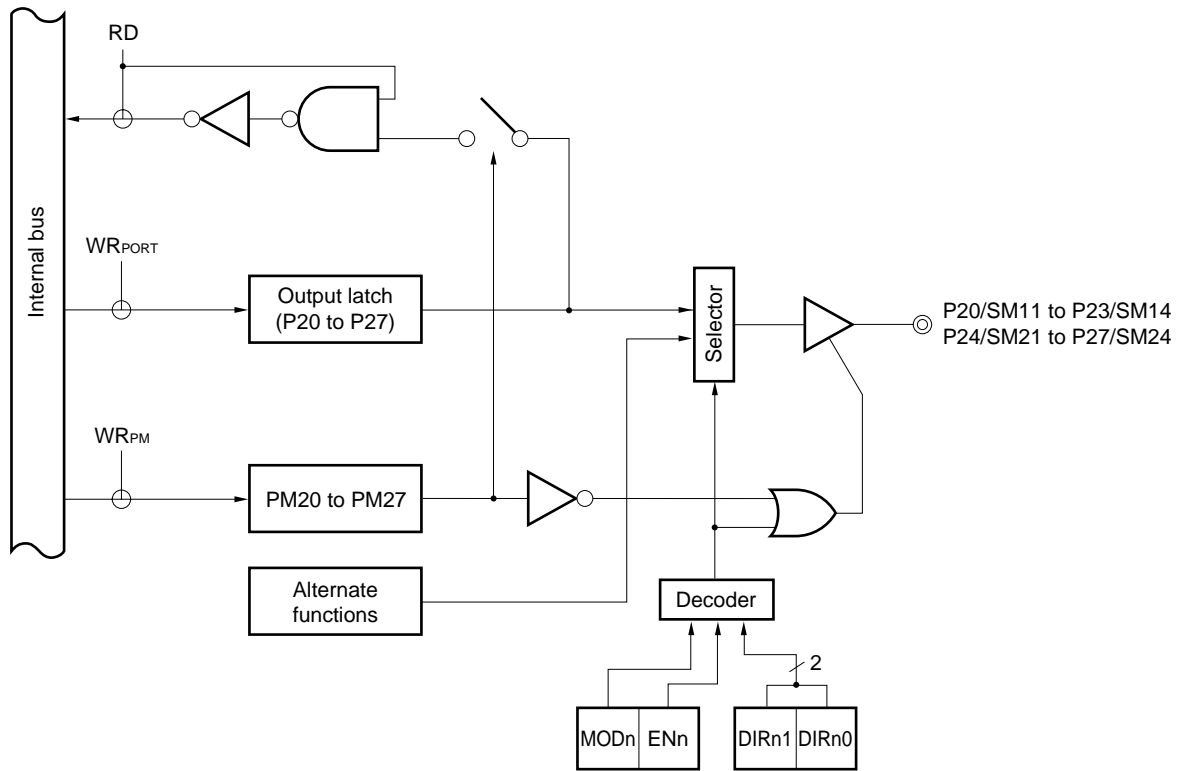

- PM : Port mode register
- RD : Port 2 read signal
- WR : Port 2 write signal

Caution When PM2 is set to 0, read operation is enabled. When PM2 is set to 1, read operation is disabled.

Remark n = 1, 2

★ 5.2.4 Port 3

Port 3 is an 8-bit output only port with output latch. P30 to P37 pins go into a high-impedance state when the ENn of port mode control register (PMC) is set to 0 and the port mode register 3 (PM3) is set to 1.

Alternate functions include meter control PWM output.

$\overline{\text{RESET}}$ input sets port 3 to high-impedance state.

Figure 5-5 shows a block diagram of port 3.

Figure 5-5. P30 to P37 Block Diagram

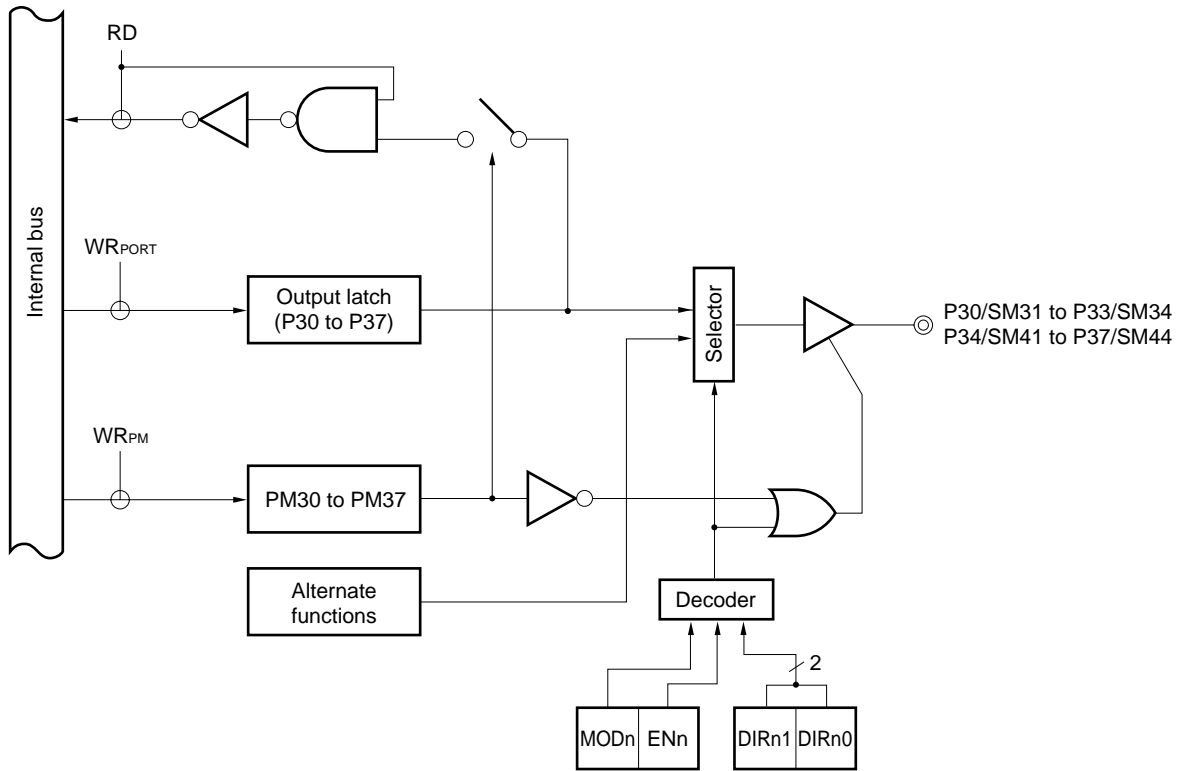

- PM : Port mode register
- RD : Port 3 read signal
- WR : Port 3 write signal

Caution When PM3 is set to 0, read operation is enabled. When PM3 is set to 1, read operation is disabled.

Remark n = 3, 4

5.2.5 Port 4

Port 4 is a 5-bit input/output port with output latch. P40 to P44 pins can specify the input mode/output mode in 1-bit units with the port mode register 4 (PM4).

Alternate functions also include timer input/output.

$\overline{\text{RESET}}$ input sets port 4 to input mode.

Figure 5-6 shows a block diagram of port 4.

Figure 5-6. P40 to P44 Block Diagram

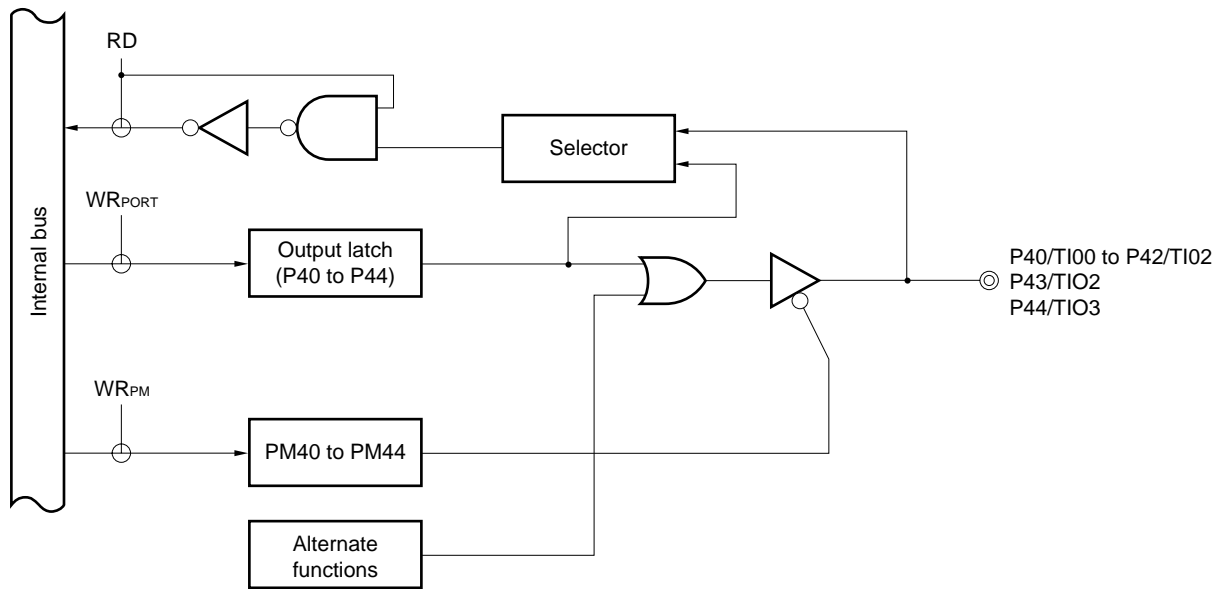

- PM : Port mode register
- RD : Port 4 read signal
- WR : Port 4 write signal

5.2.6 Port 5

Port 5 is a 5-bit input/output port with output latch. P50 to P54 pins can specify the input mode/output mode in 1-bit units with the port mode register 5 (PM5).

Alternate functions include serial interface data input/output and clock input/output.

$\overline{\text{RESET}}$ input sets port 5 to input mode.

Figure 5-7 shows a block diagram of port 5.

Figure 5-7. P50 to P54 Block Diagram

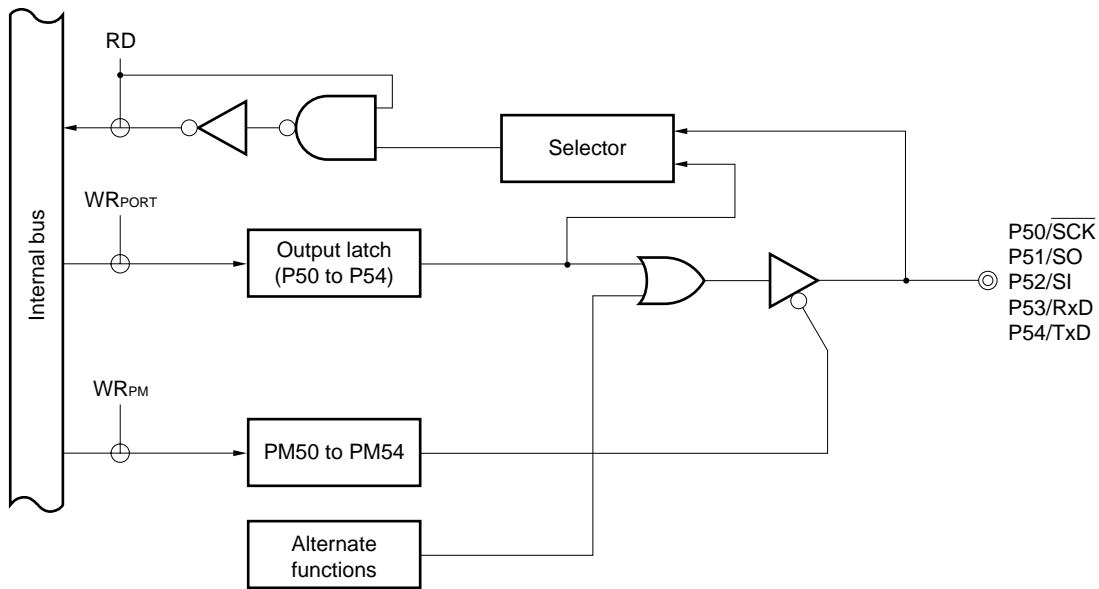

- PM : Port mode register
- RD : Port 5 read signal
- WR : Port 5 write signal

5.2.7 Port 6

Port 6 is a 2-bit input/output port with output latch. P60 and P61 pins can specify the input mode/output mode in 1-bit units with the port mode register 6 (PM6).

Alternate functions include clock output and sound generator output.

$\overline{\text{RESET}}$ input sets port 6 to input mode.

Figure 5-8 shows a block diagram of port 6.

Figure 5-8. P60 and P61 Block Diagram

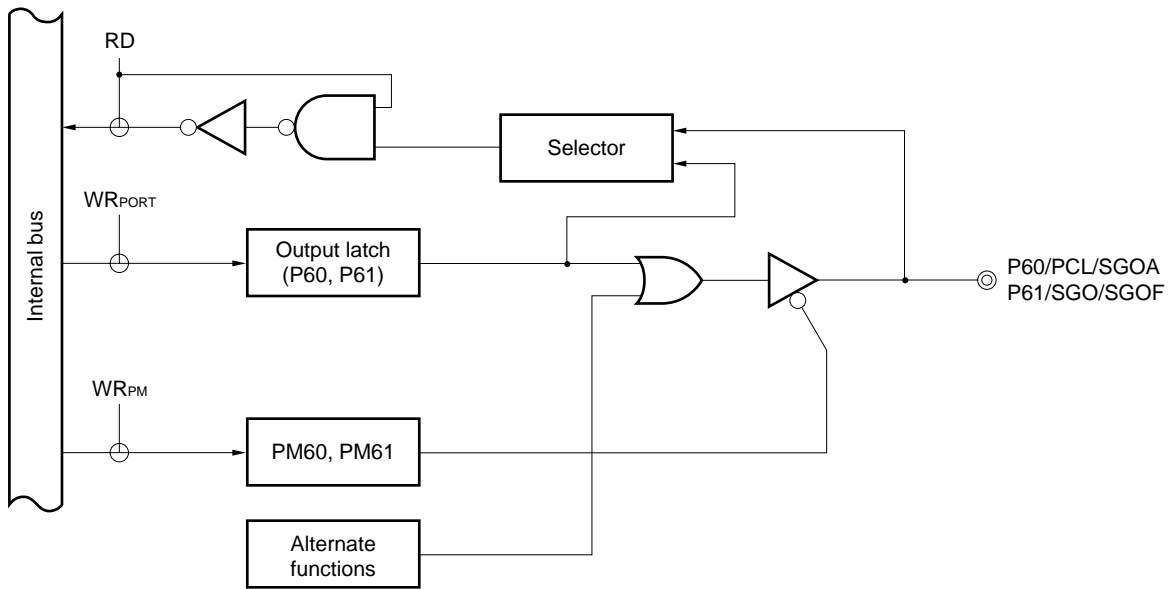

PM : Port mode register
 RD : Port 6 read signal
 WR : Port 6 write signal

★ 5.2.8 Port 8

Port 8 is a 7-bit input/output port with output latch. P81 to P87 pins can specify the input mode/output mode in 1-bit units with the port mode register 8 (PM8).

Alternate functions also include segment signal output of the LCD controller/driver and prescaler signal output. Segment output and input/output port can be switched by setting the LCD display control register (LCDC).

$\overline{\text{RESET}}$ input sets port 8 to input mode.

Figures 5-9 and 5-10 show block diagrams of port 8.

Figure 5-9. P81 Block Diagram

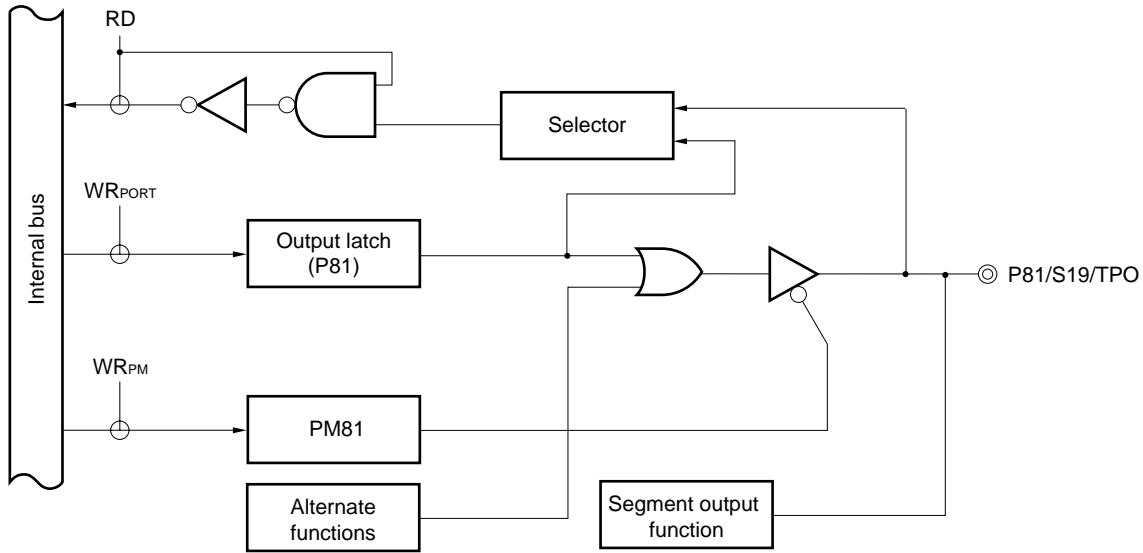
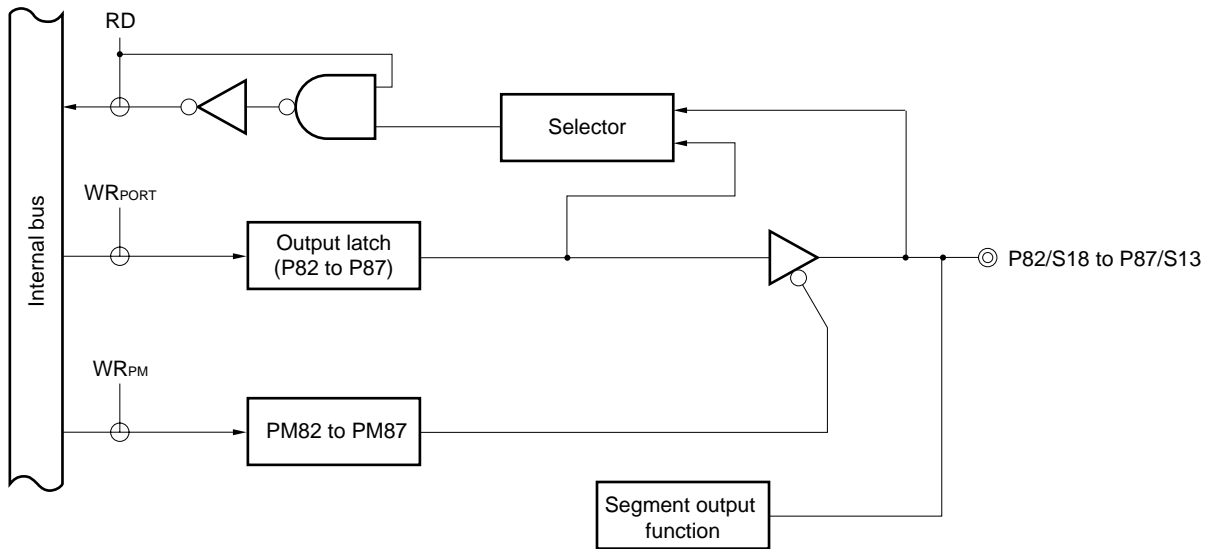

Figure 5-10. P82 to P87 Block Diagram



- PM : Port mode register
- RD : Port 8 read signal
- WR : Port 8 write signal

★ 5.2.9 Port 9

Port 9 is an 8-bit input/output port with output latch. P90 to P97 pins can specify the input mode/output mode in 1-bit units with the port mode register 9 (PM9).

Alternate functions also include segment signal output of the LCD controller/driver.

Segment output and input/output port can be switched by setting the LCD display control register (LCDC).

$\overline{\text{RESET}}$ input sets port 9 to input mode.

Figure 5-11 shows a block diagram of port 9.

Figure 5-11. P90 to P97 Block Diagram

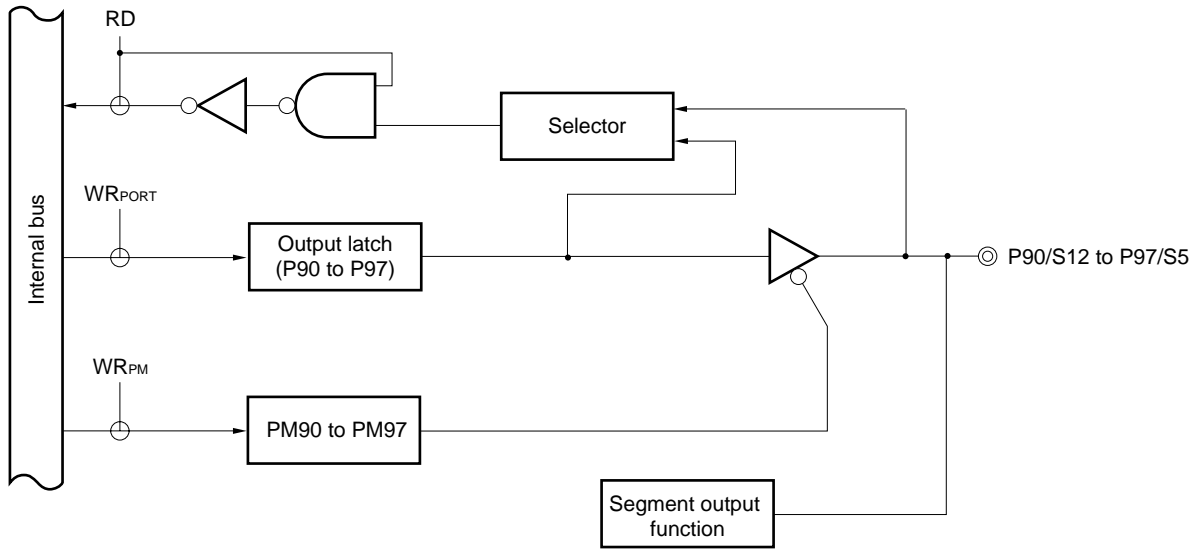

- PM : Port mode register
- RD : Port 9 read signal
- WR : Port 9 write signal

5.3 Port Function Control Registers

The following two types of registers control the ports.

- Port mode registers (PM0, PM2 to PM6, PM8, PM9)
- Pull-up resistor option register (PU0)

(1) Port mode registers (PM0, PM2 to PM6, PM8, PM9)

These registers are used to set port input/output in 1-bit units.

PM0, PM2 to PM6, PM8, and PM9 are independently set with a 1-bit or 8-bit memory manipulation instruction. $\overline{\text{RESET}}$ input sets registers to FFH.

- Cautions**
1. Pins P10 and P14 are input-only pins, and pins P20 to P27 and P30 to P37 are output-only pins.
 2. Port 0 has an alternate function as external interrupt request input, when the port function output mode is specified and the output level is changed, the interrupt request flag is set. When the output mode is used, therefore, the interrupt mask flag should be set to 1 beforehand.
 3. Ports 2 and 3 that can be also used as meter driving PWM signal output pins go into a high-impedance state when 1 is set to PM2_x and PM3_x, respectively.

★

Table 5-3. Port Mode Register and Output Latch Settings when Using Alternate Functions

Pin Name	Alternate Functions		PM _{xx}	P _{xx}
	Name	Input/Output		
P00	INTP0	Input	1	×
P01	INTP1	Input	1	×
P02	INTP2	Input	1	×
P10 to P14 Note 1	ANI0 to ANI4	Input	1	×
P20 to P27	SM11 to SM24	Output	0 Note 2	×
P30 to P37	SM31 to SM44	Output	0 Note 2	×
P40 to P42	TIO0 to TIO2	Input	1	×
P43, P44	TIO2, TIO3	Output	0	0
P60	SGOA/PCL	Output	0	0
P61	SGO/SGOF	Output	0	0
P81, P82 to P87	S19/TPO, S18 to S13	Output	× Note 3	
P90 to P97	S12 to S5	Output	× Note 3	

- Notes**
1. If these ports are read out when these pins are used in the alternate function mode, undefined values are read.
 2. The P20 to P27 and P30 to P37 pins have an alternate function as meter driving PWM signal output. When 0 is set to EN_n (n = 1 to 4) of port mode control register (PMC) and 1 is set to PM_{xx}, these pins go into the high-impedance state. Refer to the port mode register format.
 3. When the P81 to P87 and P90 to P97 pins are used for alternate functions, set the function with the LCD display control register (LCDC).

Caution When port 5 is used for serial interface, the I/O latch or output latch must be set according to their function. For the setting methods, see Figure 14-2 Asynchronous Serial Interface Mode Register (ASIM) Format and Figure 15-2 Serial Operation Mode Register (CSIM) Format.

Remark

- × : don't care
- PM_{xx} : port mode register
- P_{xx} : port output latch

Figure 5-12. Port Mode Register (PM0, PM4 to PM6, PM8, PM9) Format

Address: FF20H After Reset : FFH R/W

Symbol	7	6	5	4	3	2	1	0
PM0	PM07	PM06	PM05	PM04	PM03	PM02	PM01	PM00

Address: FF24H After Reset : FFH R/W

Symbol	7	6	5	4	3	2	1	0
PM4	1	1	1	PM44	PM43	PM42	PM41	PM40

Address: FF25H After Reset : FFH R/W

Symbol	7	6	5	4	3	2	1	0
PM5	1	1	1	PM54	PM53	PM52	PM51	PM50

Address: FF26H After Reset : FFH R/W

Symbol	7	6	5	4	3	2	1	0
PM6	1	1	1	1	1	1	PM61	PM60

Address: FF28H After Reset : FFH R/W

Symbol	7	6	5	4	3	2	1	0
PM8	PM87	PM86	PM85	PM84	PM83	PM82	PM81	1

Address: FF29H After Reset : FFH R/W

Symbol	7	6	5	4	3	2	1	0
PM9	PM97	PM96	PM95	PM94	PM93	PM92	PM91	PM90

PMmn	Pmn Pin Input/Output Mode Select (m = 0, 4 to 6, 8, 9 ; n = 0 to 7)
0	Output Mode (Output buffer on)
1	Input Mode (Output buffer off)

★

Figure 5-13. Port Mode Register (PM2, PM3) Format

Address: FF22H After Reset : FFH R/W

Symbol	7	6	5	4	3	2	1	0
PM2	PM27	PM26	PM25	PM24	PM23	PM22	PM21	PM20

Address: FF23H After Reset : FFH R/W

Symbol	7	6	5	4	3	2	1	0
PM3	PM37	PM36	PM35	PM34	PM33	PM32	PM31	PM30

PMmn	Pmn Pin Input/Output Mode Select (m = 2, 3 ; n = 0 to 7)
0	Output Mode (Output buffer on)
1	High-impedance state (Output buffer off) Note

Note When 0 is set to ENn of port mode control register (PMC)

(2) Pull-up resistor option register (PU0)

This register is used to set whether to use an internal pull-up resistor at port 0 or not. A pull-up resistor is internally used at bits which are set to the input mode at a port where pull-up resistor use has been specified with PU0. No pull-up resistors can be used to the bits set to the output mode irrespective of PU0 setting.

PU0 is set with a 1-bit or 8-bit memory manipulation instruction.

$\overline{\text{RESET}}$ input sets this register to 00H.

Figure 5-14. Pull-Up Resistor Option Register (PU0) Format

Address: FF30H After Reset : 00H R/W

Symbol	7	6	5	4	3	2	1	0
PU0	PU07	PU06	PU05	PU04	PU03	PU02	PU01	PU00

PU0m	P0m Pin Internal Pull-Up Resistor Select (m = 0 to 7)
0	On-chip pull-up resistor not used
1	On-chip pull-up resistor used

5.4 Port Function Operations

Port operations differ depending on whether the input or output mode is set, as shown below.

5.4.1 Writing to input/output port

(1) Output mode

A value is written to the output latch by a transfer instruction, and the output latch contents are output from the pin.

Once data is written to the output latch, it is retained until data is written to the output latch again.

(2) Input mode

A value is written to the output latch by a transfer instruction, but since the output buffer is OFF, the pin status does not change.

Once data is written to the output latch, it is retained until data is written to the output latch again.

Caution In the case of 1-bit memory manipulation instruction, although a single bit is manipulated, the port is accessed as an 8-bit unit. Therefore, on a port with a mixture of input and output pins, the output latch contents for pins specified as input are undefined, even for bits other than the manipulated bit.

5.4.2 Reading from input/output port

(1) Output mode

The output latch contents are read by a transfer instruction. The output latch contents do not change.

(2) Input mode

The pin status is read by a transfer instruction. The output latch contents do not change.

5.4.3 Operations on input/output port

(1) Output mode

An operation is performed on the output latch contents, and the result is written to the output latch. The output latch contents are output from the pins.

Once data is written to the output latch, it is retained until data is written to the output latch again.

(2) Input mode

The output latch contents are undefined, but since the output buffer is OFF, the pin status does not change.

Caution In the case of 1-bit memory manipulation instruction, although a single bit is manipulated, the port is accessed as an 8-bit unit. Therefore, on a port with a mixture of input and output pins, the output latch contents for pins specified as input are undefined, even for bits other than the manipulated bit.

CHAPTER 6 CLOCK GENERATOR

6.1 Clock Generator Functions

The clock generator generates the clock to be supplied to the CPU and peripheral hardware.

- **Main system clock oscillator**

This circuit oscillates at frequencies of 4.19 to 8.38 MHz. Oscillation can be stopped by executing the STOP instruction or setting the processor clock control register (PCC).

6.2 Clock Generator Configuration

The clock generator consists of the following hardware.

★

Table 6-1. Clock Generator Configuration

Item	Configuration
Control register	Processor clock control register (PCC) Oscillator mode register (OSCM) Note
Oscillator	Main system clock oscillator

Note μ PD780973(A) only

★

Figure 6-1. Clock Generator Block Diagram

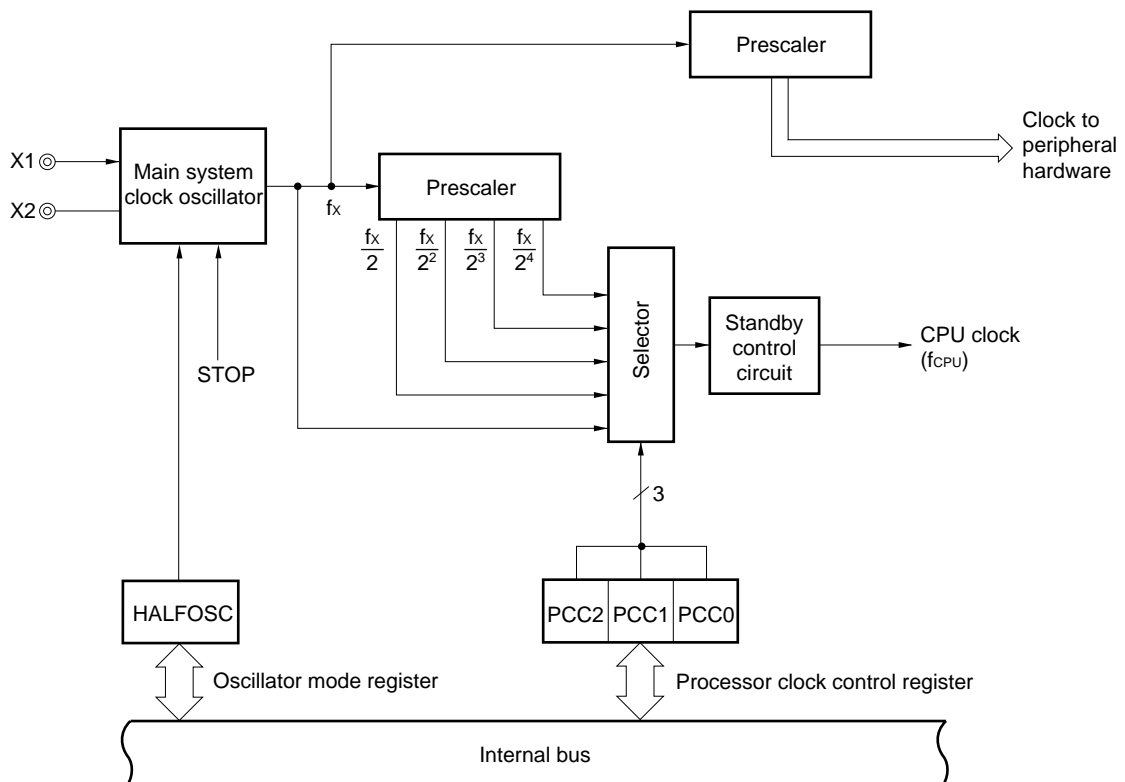

6.3 Clock Generator Control Register

The following two types of registers are used to control the clock generator.

- Processor clock control register (PCC)
- Oscillator mode register (OSCM)

(1) Processor clock control register (PCC)

The PCC sets the division ratio of the CPU clock.

The PCC is set with a 1-bit or 8-bit memory manipulation instruction.

$\overline{\text{RESET}}$ input sets the PCC to 04H.

Figure 6-2. Processor Clock Control Register (PCC) Format

Address: FFFBH After Reset: 04H R/W

Symbol	7	6	5	4	3	2	1	0
PCC	0	0	0	0	0	PCC2	PCC1	PCC0

PCC2	PCC1	PCC0	CPU Clock (f_{CPU}) Select
0	0	0	f_x
0	0	1	$f_x/2$
0	1	0	$f_x/2^2$
0	1	1	$f_x/2^3$
1	0	0	$f_x/2^4$
Other than above			Setting prohibited

Caution Bits 3 to 7 must be set to 0.

Remark f_x : Main system clock oscillation frequency

The fastest instructions of the $\mu\text{PD780973}$ Subseries are executed in two CPU clocks. Therefore, the relation between the CPU clock (f_{CPU}) and the minimum instruction execution time is as shown in Table 6-2.

Table 6-2. Relation between CPU Clock and Minimum Instruction Execution Time

CPU Clock (f_{CPU})	Minimum Instruction Execution Time: $2/f_{\text{CPU}}$	
	$f_x = 8 \text{ MHz}$	$f_x = 8.38 \text{ MHz}$
f_x	0.25 μs	0.24 μs
$f_x/2$	0.5 μs	0.48 μs
$f_x/2^2$	1.0 μs	0.95 μs
$f_x/2^3$	2.0 μs	1.91 μs
$f_x/2^4$	4.0 μs	3.81 μs

Remark f_x : Main system clock oscillation frequency

★ **(2) Oscillator mode register (OSCM)**

The μ PD780973(A) can be set to the reduced current consumption mode by setting OSCM (only when operated at $f_x = 4$ to 4.19 MHz).

OSCM is set with a 1-bit or 8-bit memory manipulation instruction.

RESET input sets OSCM to 00H.

Figure 6-3. Oscillator Mode Register (OSCM) Format

Address: FFA0H After Reset: 00H R/W

Symbol	7	6	5	4	3	2	1	0
OSCM	HALFOSC	0	0	0	0	0	0	0

HALFOSC	Oscillator Mode Selection
0	Normal operation mode
1	Reduced current consumption mode (only when operated at $f_x = 4$ to 4.19 MHz)

- Cautions**
1. This function is available only when the device is operated at $f_x = 4$ to 4.19 MHz. In other cases, be sure not to set 1 to bit 7.
 2. When using in normal operation mode, setting OSCM is not necessary.
 3. Only the first setting of OSCM is effective.

6.4 System Clock Oscillator

6.4.1 Main system clock oscillator

The main system clock oscillator oscillates with a crystal resonator or a ceramic resonator (standard: 8.38 MHz) connected to the X1 and X2 pins.

External clocks can be input to the main system clock oscillator. In this case, input a clock signal to the X1 pin and an inverted clock signal to the X2 pin.

Figure 6-4 shows an external circuit of the main system clock oscillator.

Figure 6-4. External Circuit of Main System Clock Oscillator

(a) Crystal and ceramic oscillation

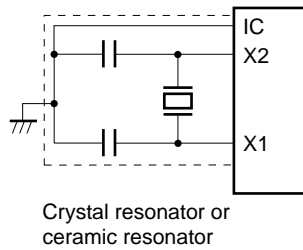

(b) External clock

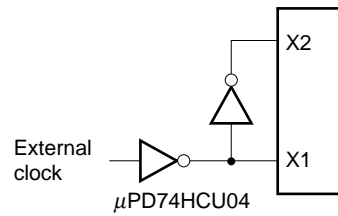

Caution Do not execute the STOP instruction while an external clock is input. This is because if the STOP instruction is executed, the main system clock operation is stopped, and the X2 pin is connected to V_{DD} , via a pull-up resistor.

Caution When using a main system clock oscillator, carry out wiring in the broken line area in Figure 6-4 as follows to avoid influence of wiring capacity.

- Keep the wiring length as short as possible.
- Do not cross the wiring with any other signal lines. Do not route the wiring in the vicinity of a line through which a high alternating current flows.
- Always keep the ground of the capacitor of the oscillator at the same potential as V_{SS} . Do not ground the capacitor to a ground pattern through which a high current flows.
- Do not fetch signals from the oscillator.

Figure 6-5 shows examples of resonator having bad connection.

Figure 6-5. Incorrect Examples of Resonator Connection (1/2)

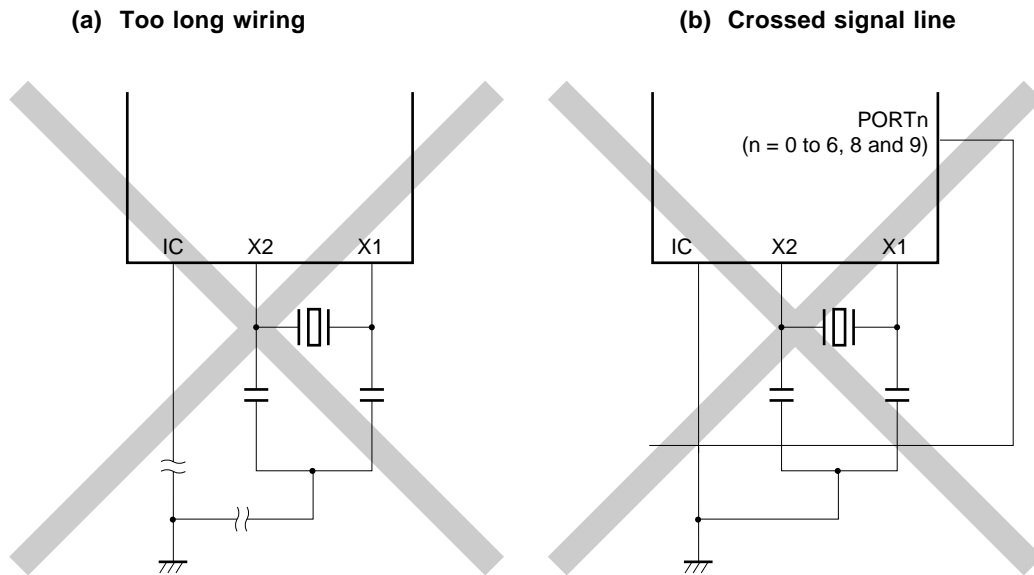
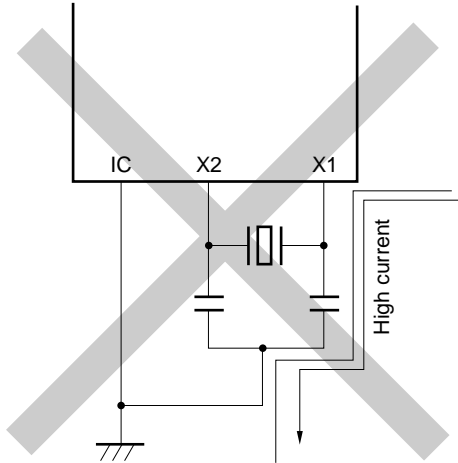
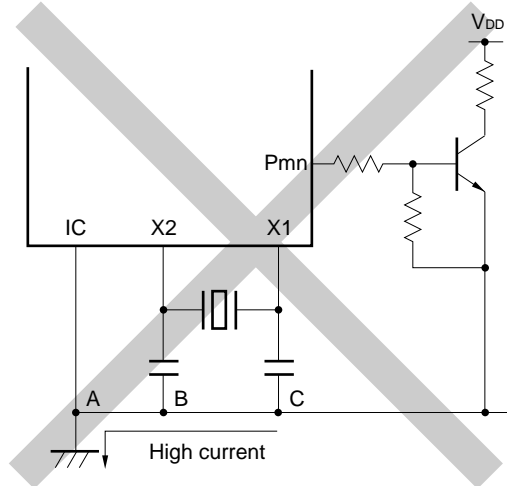

Figure 6-5. Incorrect Examples of Resonator Connection (2/2)

(c) Wiring near high alternating current



(d) Current flowing through ground line of oscillator (potential at points A, B, and C fluctuates)



(e) Signals are fetched

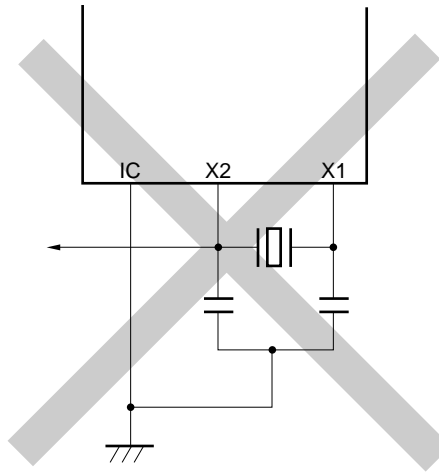

6.4.2 Divider circuit

The divider circuit divides the output of the main system clock oscillation circuit (f_x) to generate various clocks.

6.5 Operation of Clock Generator

The clock generator generates the following clocks and controls the operation modes of the CPU, such as the standby mode:

- Main system clock f_x
- CPU clock f_{CPU}
- Clock to peripheral hardware

The operation of the clock generator is determined by the processor clock control register (PCC) and oscillator mode register (OSCM) as follows:

- (a) The slowest mode (3.81 μ s: at 8.38-MHz operation) of the main system clock is selected when the $\overline{\text{RESET}}$ signal is generated (PCC = 04H). While a low level is input to the $\overline{\text{RESET}}$ pin, oscillation of the main system clock is stopped.
- (b) Five types of CPU clocks (0.24 μ s, 0.48 μ s, 0.95 μ s, 1.91 μ s, and 3.81 μ s: at 8.38-MHz operation) can be selected by the PCC setting.
- (c) Two standby modes, STOP and HALT, can be used.
- (d) The clock to the peripheral hardware is supplied by dividing the main system clock. The other peripheral hardware is stopped when the main system clock is stopped (except, however, the external clock input operation).
- ★ (e) The μ PD780973(A) can be set to the reduced current consumption mode by setting OSCM (only when operated at $f_x = 4$ to 4.19 MHz). Setting 1 to bit 7 (HALFOSC) of OSCM will reduce the power consumption.

- Cautions**
1. This function is available only when the device is operated at $f_x = 4$ to 4.19 MHz. In other cases, be sure not to set 1 to bit 7.
 2. When using in normal operation mode, setting OSCM is not necessary.
 3. Only the first setting of OSCM is effective.

6.6 Changing Setting of CPU Clock

6.6.1 Time required for switching CPU clock

The CPU clock can be selected by using bits 0 to 2 (PCC0 to PCC2) of the processor clock control register (PCC).

Actually, the specified clock is not selected immediately after the setting of PCC has been changed, and the old clock is used for the duration of several instructions after that (refer to **Table 6-3**).

Table 6-3. Maximum Time Required for Switching CPU Clock

Set Value before Switching			Set Value after Switching														
PCC2	PCC1	PCC0	PCC2	PCC1	PCC0	PCC2	PCC1	PCC0	PCC2	PCC1	PCC0	PCC2	PCC1	PCC0	PCC2	PCC1	PCC0
0	0	0	0	0	0	0	0	1	0	1	0	0	1	1	1	0	0
0	0	0	16 instructions			16 instructions			16 instructions			16 instructions					
0	0	1	8 instructions			8 instructions			8 instructions			8 instructions					
0	1	0	4 instructions			4 instructions			4 instructions			4 instructions					
0	1	1	2 instructions			2 instructions			2 instructions			2 instructions					
1	0	0	1 instruction			1 instruction			1 instruction			1 instruction					

Remark One instruction is the minimum instruction execution time of the CPU clock before switching.

6.6.2 Switching CPU clock

The following figure illustrates how the CPU clock switches.

Figure 6-6. Switching CPU Clock

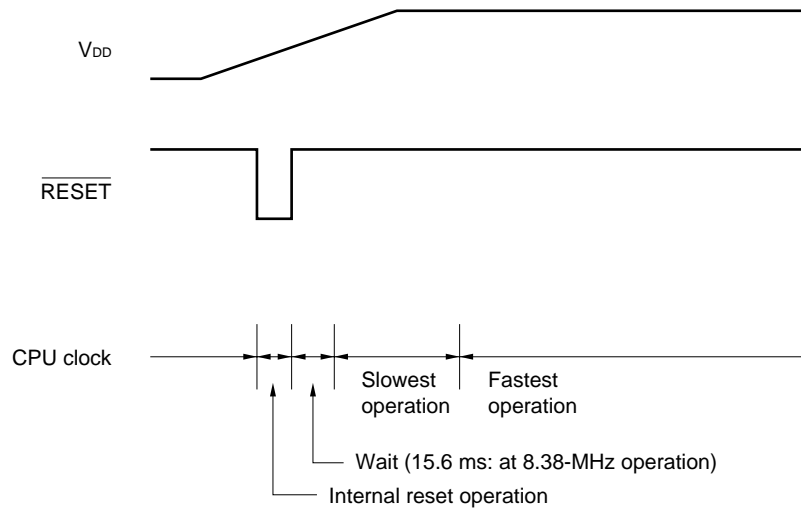

- <1> The CPU is reset when the \overline{RESET} pin is made low on power application. The effect of resetting is released when the \overline{RESET} pin is later made high, and the main system clock starts oscillating. At this time, the time during which oscillation stabilizes ($2^{17}/f_x$) is automatically secured. After that, the CPU starts instruction execution at the slowest speed of the main system clock (3.81 μs : at 8.38-MHz operation).
- <2> After the time during which the V_{DD} voltage rises to the level at which the CPU can operate at the highest speed has elapsed, PCC is rewritten so that the highest speed can be selected.

[MEMO]

CHAPTER 7 16-BIT TIMER 0 TM0

7.1 Outline of Internal Timer of μ PD780973 Subseries

This chapter explains the 16-bit timer 0. Before that, the internal timers of the μ PD780973 Subseries, and the related functions are briefly explained below.

(1) 16-bit timer 0 TM0

The TM0 can be used for pulse widths measurement, divided output of input pulse.

(2) 8-bit timer 1 TM1

The TM1 can be used for an interval timer (See **CHAPTER 8 8-BIT TIMER 1 TM1**).

(3) 8-bit timer/event counters 2, 3 TM2, TM3

TM2 and TM3 can be used to serve as an interval timer and an external event counter and to output square waves with any selected frequency, PWM output (See **CHAPTER 9 8-BIT TIMER/EVENT COUNTERS 2, 3 TM2, TM3**).

(4) Watch timer

This timer can set a flag every 0.5 sec. and simultaneously generates interrupt request at the preset time intervals (See **CHAPTER 10 WATCH TIMER**).

(5) Watchdog timer

This timer can perform the watchdog timer function or generate non-maskable interrupt request, maskable interrupt request and $\overline{\text{RESET}}$ at the preset time intervals (See **CHAPTER 11 WATCHDOG TIMER**).

(6) Clock output control circuit

Clock output supplies other devices with the divided main system clock (See **CHAPTER 12 CLOCK OUTPUT CONTROL CIRCUIT**).

Table 7-1. Timer/Event Counter Operations

		16-bit Timer TM0	8-bit Timer TM1	8-bit Timer/Event Counter TM2, TM3	Watch Timer	Watchdog Timer
Operating mode	Interval timer	–	1 channel	2 channels	1 channel Note 1	1 channel Note 2
	External event counter	–	–	○	–	–
Function	Timer output	–	–	○	–	–
	PWM output	–	–	○	–	–
	Pulse width measurement	○	–	–	–	–
	Square-wave output	–	–	○	–	–
	Divided output	○	–	–	–	–
	Interrupt request	○	○	○	○	○

- Notes**
1. Watch timer can perform both watch timer and interval timer functions at the same time.
 2. Watchdog timer can perform either the watchdog timer function or the interval timer function, as selected.

7.2 16-Bit Timer 0 Functions

The 16-bit timer 0 (TM0) has the following functions.

- Pulse width measurement
- Divided output of input pulse

Figure 7-1 shows 16-bit timer 0 block diagram.

Figure 7-1. Timer 0 (TM0) Block Diagram

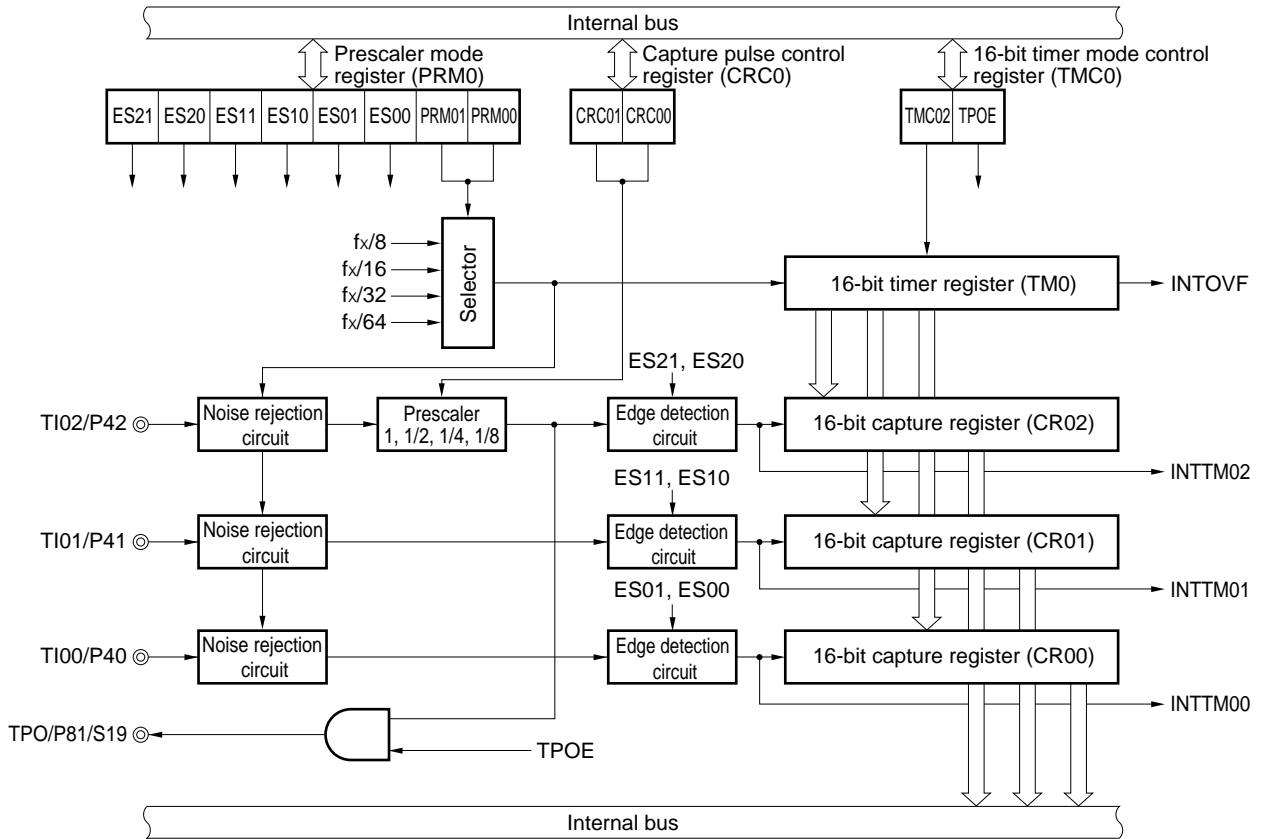

(1) Pulse width measurement

TM0 can measure the pulse width of an externally input signal.

(2) Divided output of input pulse

The frequency of an input signal can be divided and the divided signal can be output.

7.3 16-Bit Timer 0 Configuration

Timer 0 consists of the following hardware.

Table 7-2. Timer 0 Configuration

Item	Configuration
Timer register	16 bits × 1 (TM0)
Register	Capture register: 16 bits × 3 (CR00 to CR02)
Control register	16-bit timer mode control register (TMC0) Capture pulse control register (CRC0) Prescaler mode register (PRM0)

(1) 16-bit timer register (TM0)

TM0 is a 16-bit read-only register that counts count pulses.

The counter is incremented in synchronization with the rising edge of an input clock. If the count value is read during operation, input of the count clock is temporarily stopped, and the count value at that point is read. The count value is reset to 0000H in the following cases:

- <1> At $\overline{\text{RESET}}$ input
- <2> If TMC02 is cleared

(2) Capture register 00 (CR00)

The valid edge of the TI00 pin can be selected as the capture trigger. Setting of the TI00 valid edge is performed by setting of the prescaler mode register (PRM0). When the valid edge of the TI00 is detected, an interrupt request (INTTM00) is generated.

CR00 is read by a 16-bit memory manipulation instruction.

After $\overline{\text{RESET}}$ input, the value of CR00 is undefined.

(3) Capture register 01 (CR01)

The valid edge of the TI01 pin can be selected as the capture trigger. Setting of the TI01 valid edge is performed by setting of the prescaler mode register (PRM0). When the valid edge of the TI01 is detected, an interrupt request (INTTM01) is generated.

CR01 is read by a 16-bit memory manipulation instruction.

After $\overline{\text{RESET}}$ input, the value of CR01 is undefined.

(4) Capture register 02 (CR02)

The valid edge of the TI02 pin can be selected as the capture trigger. Setting of the TI02 valid edge is performed by setting of the prescaler mode register (PRM0). When the valid edge of the TI02 is detected, an interrupt request (INTTM02) is generated.

CR02 is read by a 16-bit memory manipulation instruction.

After $\overline{\text{RESET}}$ input, the value of CR02 is undefined.

7.4 16-Bit Timer 0 Control Registers

The following three types of registers are used to control timer 0.

- 16-bit timer mode control register (TMC0)
- Capture pulse control register (CRC0)
- Prescaler mode register (PRM0)

(1) 16-bit timer mode control register (TMC0)

This register sets the 16-bit timer operating mode and controls the prescaler output signals.

TMC0 is set with a 1-bit or 8-bit memory manipulation instruction.

$\overline{\text{RESET}}$ input clears TMC0 value to 00H.

Figure 7-2. 16-Bit Timer Mode Control Register (TMC0) Format

Address: FF72H After Reset: 00H R/W

Symbol	7	6	5	4	3	2	1	0
TMC0	0	0	0	0	0	TMC02	0	TPOE
TMC02	Timer 0 Operating Mode Selection							
0	Operation stop (TMO cleared to 0)							
1	Operation enabled							
TPOE	Timer 0 Prescaler Output Control							
0	Prescaler signal output disabled							
1	Prescaler signal output enabled							

- Cautions**
1. Before changing the operation mode, stop the timer operation (by setting 0 to TMC02).
 2. Bit 1 and bits 3 to 7 must be set to 0.

(2) Capture pulse control register (CRC0)

This register specifies the division ratio of the capture pulse input to the 16-bit capture register (CR02) from an external source.

CRC0 is set with a 1-bit or 8-bit memory manipulation instruction.

RESET input sets CRC0 value to 04H.

Figure 7-3. Capture Pulse Control Register (CRC0) Format

Address: FF71H After Reset: 00H R/W

Symbol	7	6	5	4	3	2	1	0
CRC0	0	0	0	0	0	0	CRC01	CRC00

CRC01	CRC00	Capture Pulse Selection
0	0	Does not divide capture pulse
0	1	Divides capture pulse by 2
1	0	Divides capture pulse by 4
1	1	Divides capture pulse by 8

- Cautions**
1. Timer operation must be stopped before setting CRC0.
 2. Bits 2 to 7 must be set to 0.

(3) Prescaler mode register (PRM0)

This register is used to set 16-bit timer (TMO) count clock and valid edge of TI0n (n = 0 to 2) input. PRM0 is set with an 8-bit memory manipulation instruction. $\overline{\text{RESET}}$ input sets PRM0 value to 00H.

Figure 7-4. Prescaler Mode Register (PRM0) Format

Address: FF70H After Reset: 00H R/W

Symbol	7	6	5	4	3	2	1	0
PRM0	ES21	ES20	ES11	ES10	ES01	ES00	PRM01	PRM00

ES21	ES20	TI02 Valid Edge Selection
0	0	Falling edge
0	1	Rising edge
1	0	Setting prohibited
1	1	Both falling and rising edges

ES11	ES10	TI01 Valid Edge Selection
0	0	Falling edge
0	1	Rising edge
1	0	Setting prohibited
1	1	Both falling and rising edges

ES01	ES00	TI00 Valid Edge Selection
0	0	Falling edge
0	1	Rising edge
1	0	Setting prohibited
1	1	Both falling and rising edges

PRM01	PRM00	Count Clock Selection
0	0	$f_x/2^3$
0	1	$f_x/2^4$
1	0	$f_x/2^5$
1	1	$f_x/2^6$

Caution Timer operation must be stopped before setting PRM0.

7.5 16-Bit Timer 0 Operations

7.5.1 Pulse width measurement operations

It is possible to measure the pulse width of the signals input to the TI00/P40 to TI02/P42 pins using the 16-bit timer register (TM0). TM0 is used in free-running mode.

(1) Pulse width measurement with free-running counter and one capture register (TI00)

When the edge specified by prescaler mode register (PRM0) is input to the TI00/P40 pin, the value of TM0 is taken into 16-bit capture register 00 (CR00) and an external interrupt request signal (INTTM00) is set. Any of three edge specifications can be selected—rising, falling, or both edges—by means of bits 2 and 3 (ES00 and ES01) of PRM0.

For valid edge detection, sampling is performed at the count clock selected by PRM0, and a capture operation is only performed when a valid level is detected twice, thus eliminating noise with a short pulse width.

Figure 7-5. Configuration Diagram for Pulse Width Measurement by Free-Running Counter

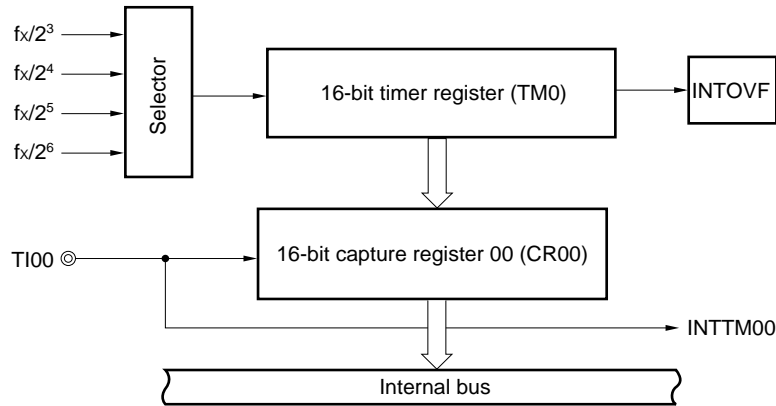
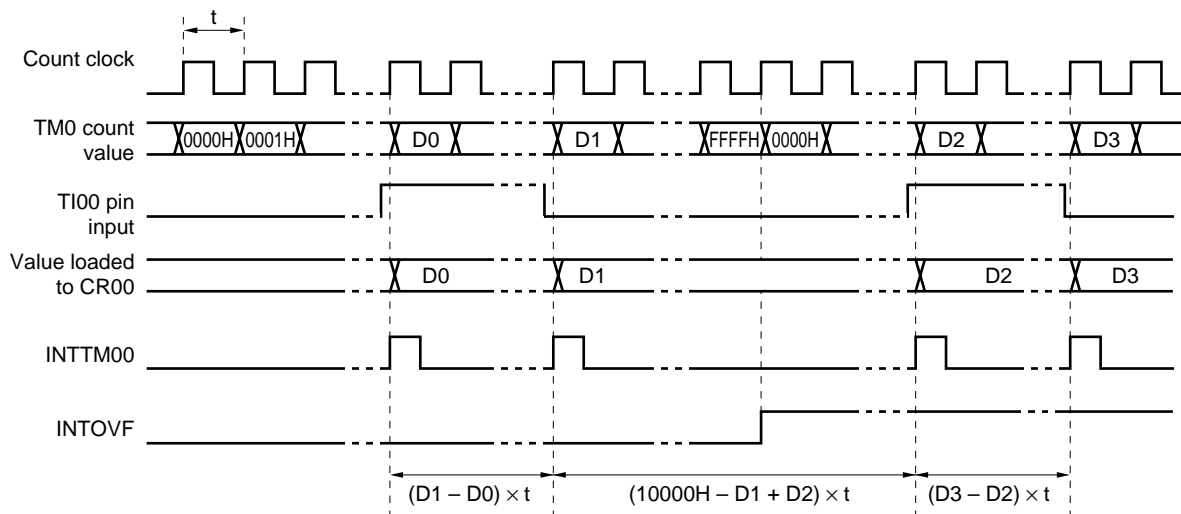

Figure 7-6. Timing of Pulse Width Measurement Operation by Free-Running Counter and One Capture Register (with Both Edges Specified)



(2) Measurement of three pulse widths with free-running counter

The 16-bit timer register (TM0) allows simultaneous measurement of the pulse widths of the three signals input to the TI00/P40 to TI02/P42 pins.

When the edge specified by bits 2 and 3 (ES00 and ES01) of prescaler mode register (PRM0) is input to the TI00/P40 pin, the value of TM0 is taken into 16-bit capture register 00 (CR00) and an external interrupt request signal (INTTM00) is set.

Also, when the edge specified by bits 4 and 5 (ES10 and ES11) of PRM0 is input to the TI01/P41 pin, the value of TM0 is taken into 16-bit capture register 01 (CR01) and an external interrupt request signal (INTTM01) is set.

When the edge specified by bits 6 and 7 (ES20 and ES21) of PRM0 is input to the TI02/P42 pin, the value of TM0 is taken into 16-bit capture register 02 (CR02) and external interrupt request signal (INTTM02) is set.

Any of three edge specifications can be selected—rising, falling, or both edges—as the valid edges for the TI00/P40 to TI02/P42 pins by means of bits 2 and 3 (ES00 and ES01), bits 4 and 5 (ES10 and ES11), and bits 6 and 7 (ES06 and ES07) of PRM0, respectively.

For TI00/P40 pin valid edge detection, sampling is performed at the interval selected by means of the prescaler mode register (PRM0), and a capture operation is only performed when a valid level is detected twice, thus eliminating noise with a short pulse width.

- **Capture operation**

Capture register operation in capture trigger input is shown.

Figure 7-7. CR0m Capture Operation with Rising Edge Specified

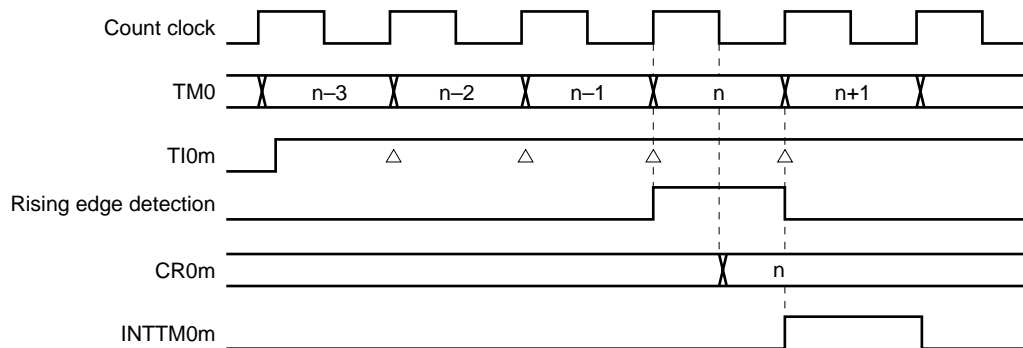

Remark $m = 0$ to 2

Figure 7-8. Timing of Pulse Width Measurement Operation by Free-Running Counter (with Both Edges Specified)

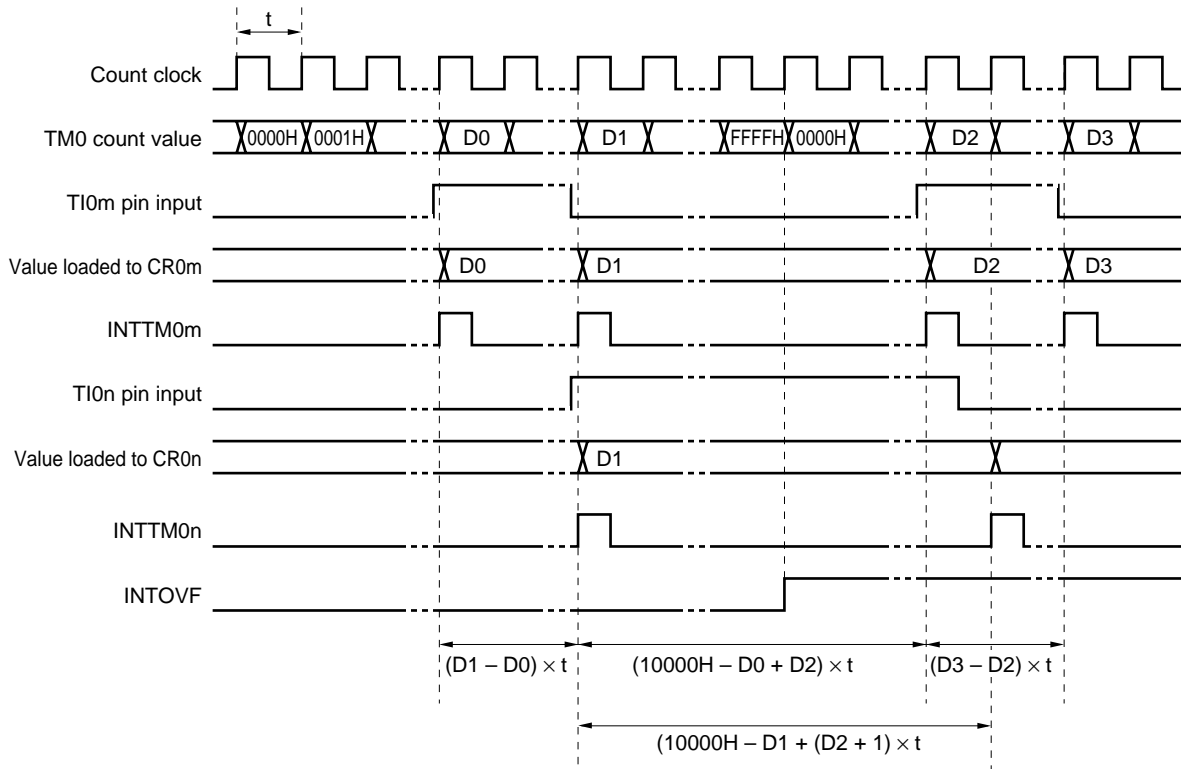

Remark $m = 0$ to 2 , $n = 1, 2$

7.6 16-Bit Timer 0 Cautions

(1) Timer start errors

An error with a maximum of one clock may occur until counting is started after timer start. This is because the 16-bit timer register (TM0) is started asynchronously with the count pulse.

Figure 7-9. 16-Bit Timer Register Start Timing

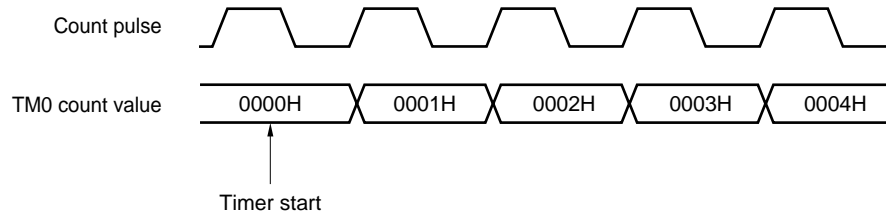

(2) Capture register data retention timings

If the valid edge of the TI0m/P4m pin is input during 16-bit capture register 0m (CR0m) read, CR0m performs capture operation, but the capture value is not guaranteed. However, the interrupt request flag (INTTM0m) is set upon detection of the valid edge.

Figure 7-10. Capture Register Data Retention Timing

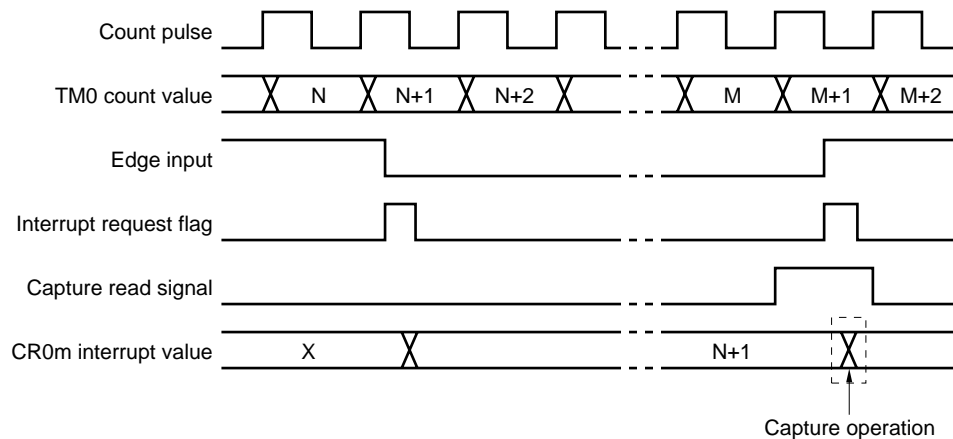

Remark m = 0 to 2

(3) Valid edge setting

Set the valid edge of the TI0m/P4m pin after setting bit 2 (TMC02) of the 16-bit timer mode control register to 0, and then stopping timer operation. Valid edge setting is carried out with bits 2 to 7 (ESm0 and ESm1) of the prescaler mode register (PRM0).

Remark m = 0 to 2

(4) Occurrence of INTTM0n

INTTM0n occurs even if no capture pulse exists, immediately after the timer operation has been started (TMC02 of TMC0 has been set to 1) with a high level applied to input pins TI00 to TI02 of 16-bit timer 0, and with the rising edge (with ESn1 and ESn0 of PRM0 set to 0, 1), or both the rising and falling edges (with ESn1 and ESn0 of PRM0 set to 1, 1) selected. However, INTTM0n does not occur if a low level is applied to TI00 to TI02.

CHAPTER 8 8-BIT TIMER 1 TM1

8.1 8-Bit Timer 1 Functions

The 8-bit timer 1 operates as an 8-bit interval timer.

Figure 8-1 shows timer 1 block diagram.

Figure 8-1. Timer 1 (TM1) Block Diagram

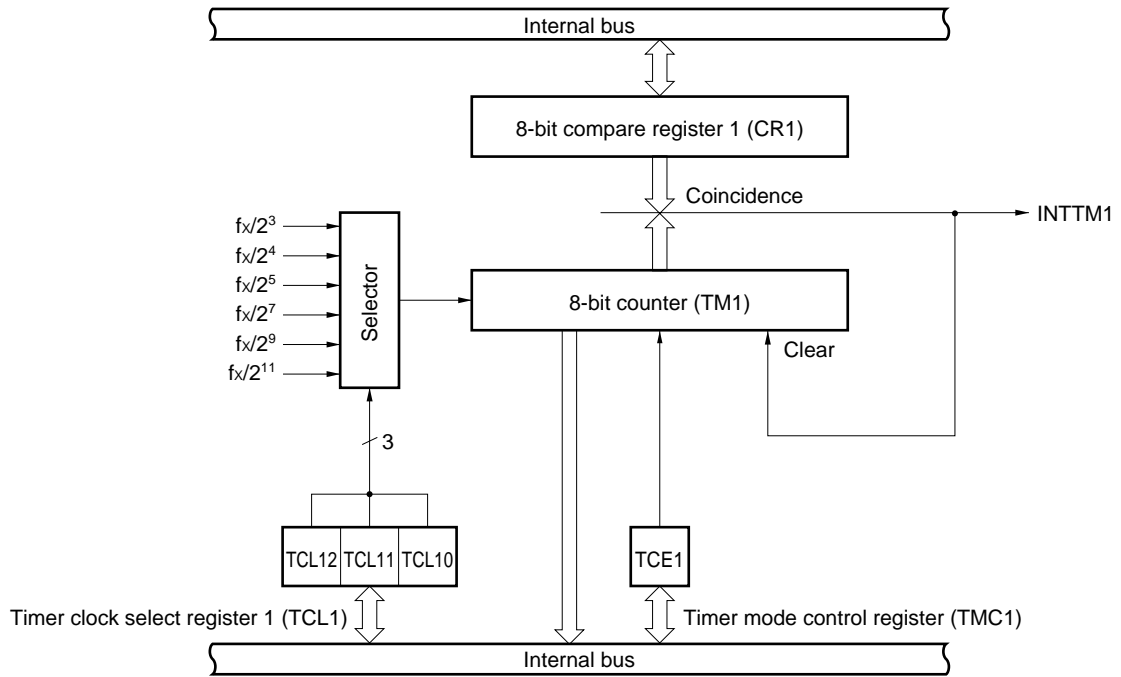

8.2 8-Bit Timer 1 Configuration

Timer 1 consists of the following hardware.

Table 8-1. Timer 1 Configuration

Item	Configuration
Timer register	8-bit counter 1 (TM1)
Register	8-bit compare register 1 (CR1)
Control register	Timer clock select register 1 (TCL1) 8-bit timer mode control register 1 (TMC1)

Remark $n = 0, 1$

(1) 8-bit counter 1 (TM1)

TM1 is an 8-bit read-only register which counts the count pulses.

The counter is incremented in synchronization with the rising edge of the count clock. When count value is read during operation, count clock input is temporary stopped, and then the count value is read. In the following situations, the count value is set to 00H.

- <1> $\overline{\text{RESET}}$ input
- <2> Clear TCE1
- <3> Match between TM1 and CR1

(2) 8-bit compare register 1 (CR1)

The value set in the CR1 is constantly compared with the 8-bit counter 1 (TM1) count value, and an interrupt request (INTTM1) is generated if they match.

It is possible to rewrite the value of CR1 within 00H to FFH during count operation.

8.3 8-Bit Timer 1 Control Registers

The following two types of registers are used to control timer 1.

- Timer clock select register 1 (TCL1)
- 8-bit timer mode control register 1 (TMC1)

(1) Timer clock select register 1 (TCL1)

This register sets count clocks of timer 1.

TCL1 is set with an 8-bit memory manipulation instruction.

RESET input clears to 00H.

Figure 8-2. Timer Clock Select Register 1 (TCL1) Format

Address: FF73H After Reset: 00H R/W

Symbol	7	6	5	4	3	2	1	0
TCL1	0	0	0	0	0	TCL12	TCL11	TCL10

TCL12	TCL11	TCL10	Count Clock Selection
0	0	0	Setting prohibited
0	0	1	Setting prohibited
0	1	0	$f_x/2^3$ (1.04 MHz)
0	1	1	$f_x/2^4$ (523 kHz)
1	0	0	$f_x/2^5$ (261 kHz)
1	0	1	$f_x/2^7$ (65.4 kHz)
1	1	0	$f_x/2^9$ (16.3 kHz)
1	1	1	$f_x/2^{11}$ (4.09 kHz)

- Cautions**
1. When rewriting TCL1 to other data, stop the timer operation beforehand.
 2. Set bits 3 to 7 to 0.

- Remarks**
1. f_x : Main system clock oscillation frequency
 2. Figures in parentheses apply to operation with $f_x = 8.38$ MHz

(2) 8-bit timer mode control register 1 (TMC1)

TMC1 is a register that controls the counting operation of the 8-bit counter 1 (TM1).

TMC1 is set with a 1-bit or 8-bit memory manipulation instruction.

$\overline{\text{RESET}}$ input sets to 04H.

Figure 8-3 shows TMC1 format.

Figure 8-3. 8-Bit Timer Mode Control Register 1 (TMC1) Format

Address: FF76H After Reset: 04H R/W

Symbol	7	6	5	4	3	2	1	0
TMC1	TCE1	0	0	0	0	1	0	0

TCE1	Timer 1 Count Operation Control
0	After clearing counter to 0, count operation disabled
1	Count operation start

Caution Be sure to set 0 to bit 0, bit 1, and bits 3 to 6, and set 1 to bit 2.

8.4 8-Bit Timer 1 Operations

8.4.1 8-bit interval timer operation

The 8-bit timer 1 operates as an interval timer which generates interrupt requests repeatedly at intervals of the count value preset to 8-bit compare register 1 (CR1).

When the count values of the 8-bit counter 1 (TM1) match the values set to CR1, counting continues with the TM1 values cleared to 0 and the interrupt request signal (INTTM1) is generated.

Count clock of the TM1 can be selected with bits 0 to 2 (TCL10 to TCL12) of the timer clock select register 1 (TCL1).

[Setting]

- <1> Set the registers.
 - TCL1 : Select count clock.
 - CR1 : Compare value
- <2> After TCE1 = 1 is set, count operation starts.
- <3> If the values of TM1 and CR1 match, the INTTM1 is generated and TM1 is cleared to 00H.
- <4> INTTM1 generates repeatedly at the same interval. Set TCE1 to 0 to stop count operation.

Figure 8-4. Interval Timer Operation Timings (1/3)

(a) Basic operation

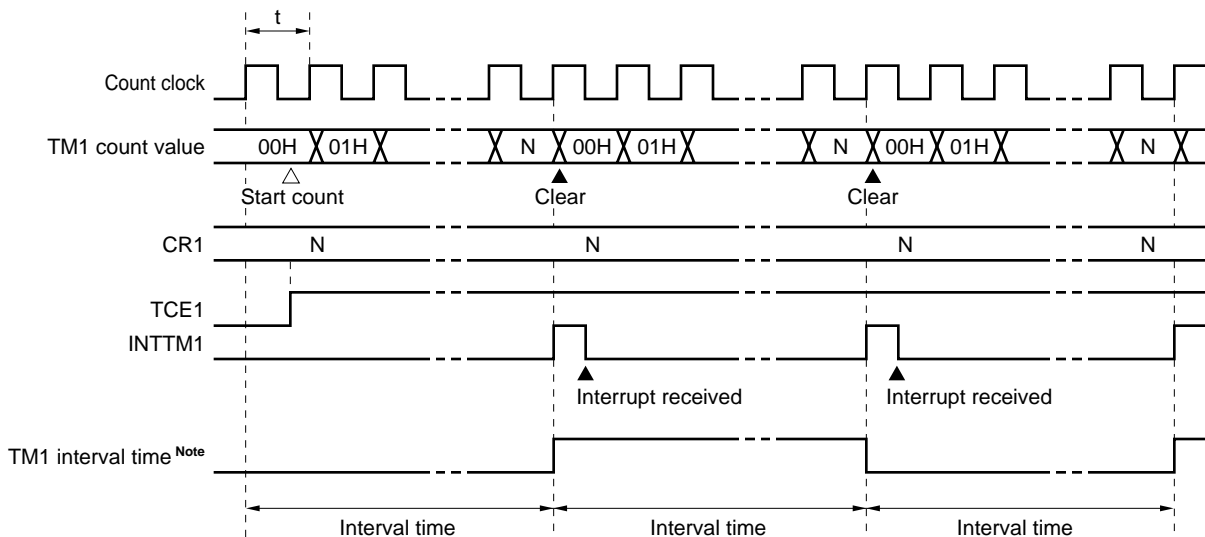

Remark Interval time = $(N + 1) \times t$: $N = 00H$ to FFH

Figure 8-4. Interval Timer Operation Timings (2/3)

(b) When CR1 = 00H

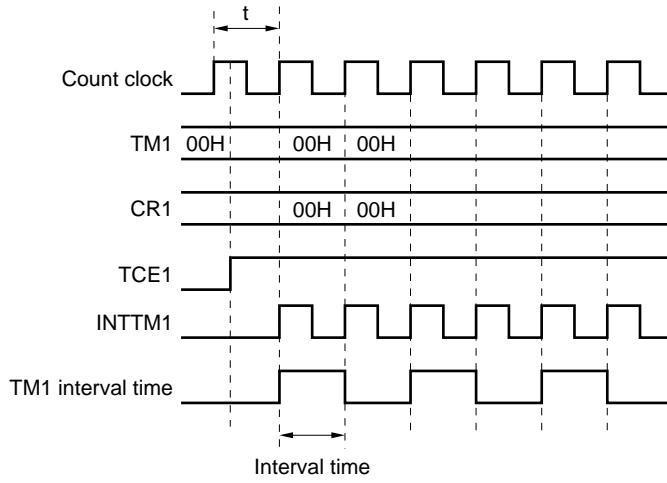

(c) When CR1 = FFH

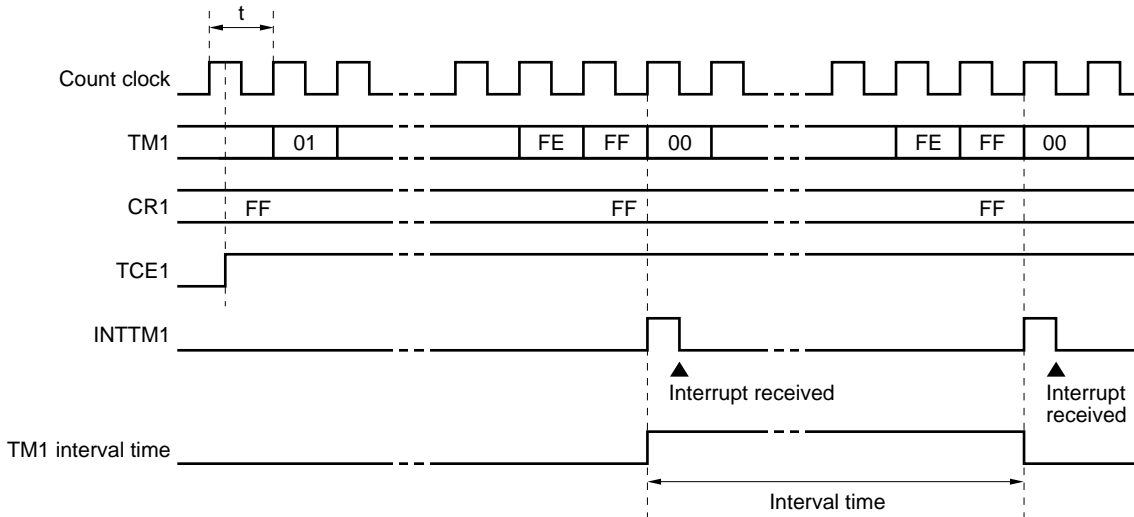
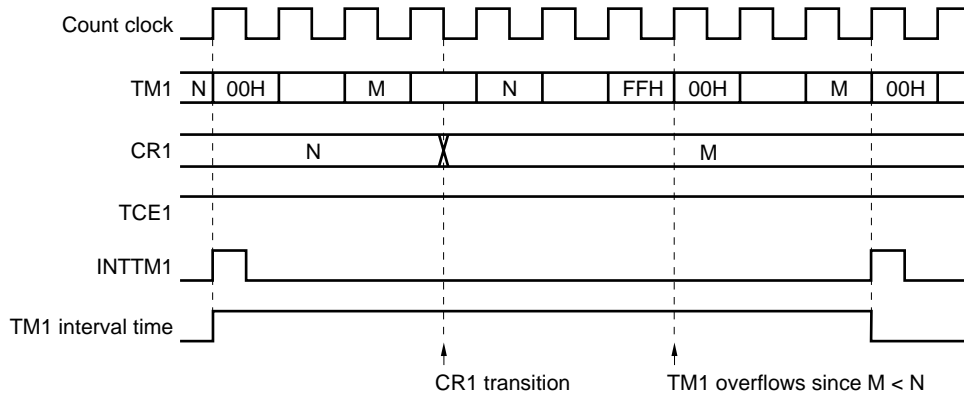
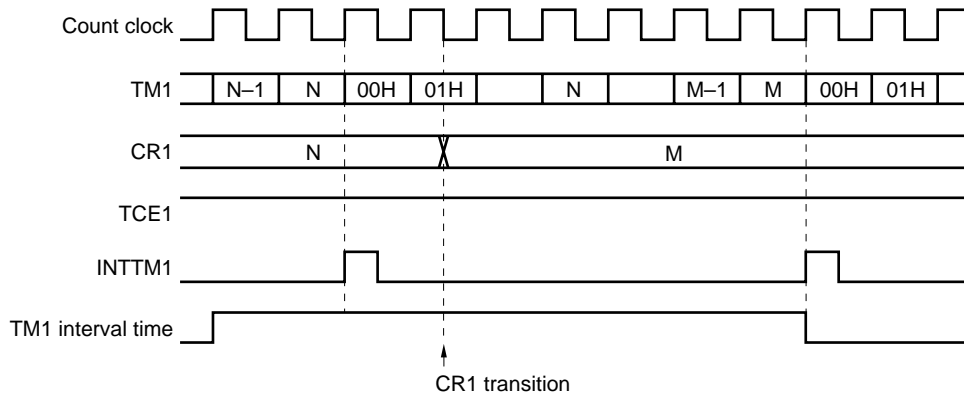

Figure 8-4. Interval Timer Operation Timings (3/3)

(d) Operated by CR1 transition ($M < N$)



(e) Operated by CR1 transition ($M > N$)



8.5 8-Bit Timer 1 Cautions

(1) Timer start errors

An error with a maximum of one clock may occur concerning the time required for a match signal to be generated after timer start. This is because 8-bit counter 1 (TM1) is started asynchronously with the count pulse.

Figure 8-5. Timer 1 Start Timing

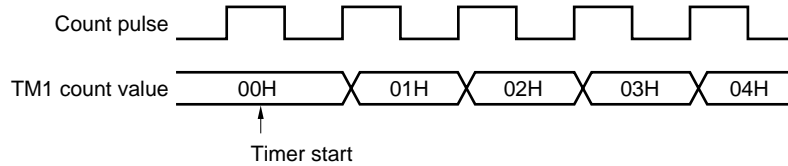

(2) Operation after compare register change during timer count operation

If the values after the 8-bit compare register 1 (CR1) is changed are smaller than the value of 8-bit timer register 1 (TM1), TM1 continues counting, overflows and then restarts counting from 0. Thus, if the value (M) after CR1 change is smaller than value (N) before the change, it is necessary to restart the timer after changing CR1.

Figure 8-6. Timing after Compare Register Change during Timer Count Operation

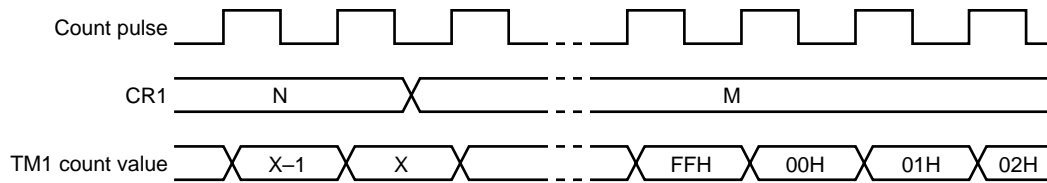

Remark $N > X > M$

Caution Always set TCE1 = 0 before setting the STOP state.

(3) TM1 reading during timer operation

When TM1 is read during operation, choose a count clock which has a longer high/low level wave because 8-bit counter (TM1) is stopped temporary.

CHAPTER 9 8-BIT TIMER/EVENT COUNTERS 2, 3 TM2, TM3

9.1 8-Bit Timer/Event Counters 2 and 3 Functions

The 8-bit timer/event counters 2 and 3 operate as an 8-bit timer/event counter. TM2 and TM3 can have the following functions.

- Interval timer
- External event counter
- Square wave output
- PWM output

Figure 9-1 shows timer 2 block diagram, and Figure 9-2 shows timer 3 block diagram.

Figure 9-1. Timer 2 (TM2) Block Diagram

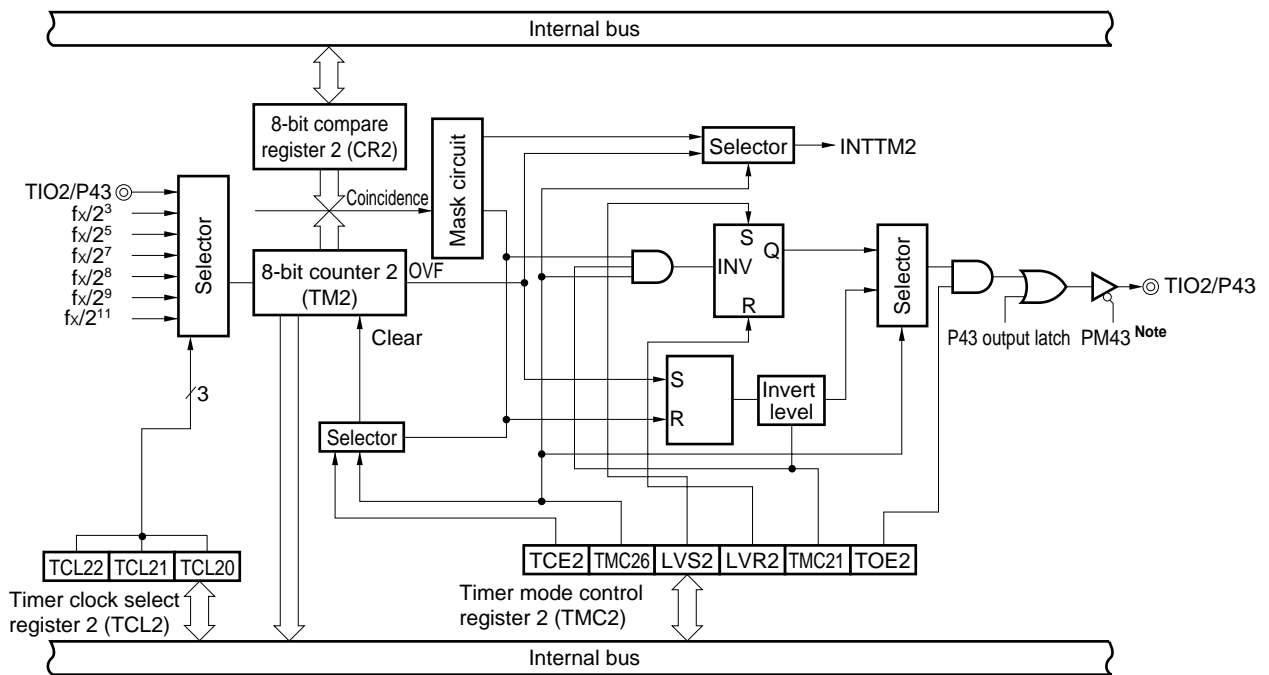

Note Bit 3 of port mode register (PM4)

Figure 9-2. Timer 3 (TM3) Block Diagram

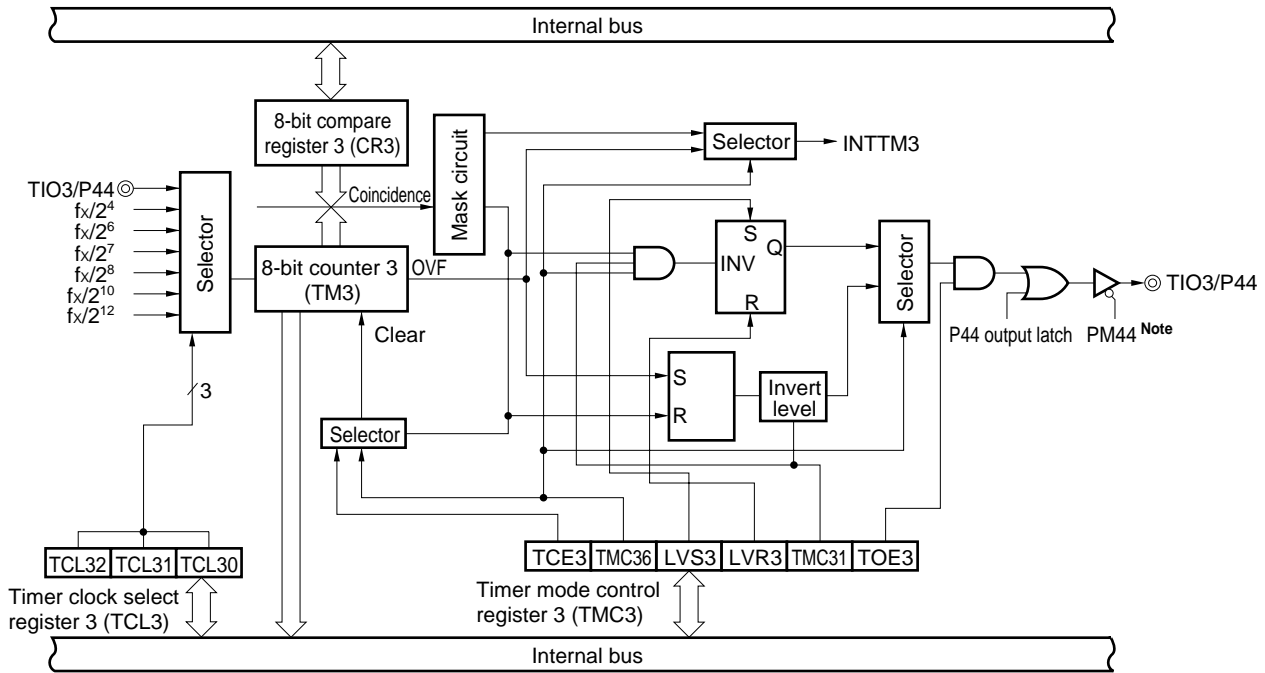

Note Bit 4 of port mode register 4 (PM4)

9.2 8-Bit Timer/Event Counters 2 and 3 Configurations

Timers 2 and 3 consist of the following hardware.

Table 9-1. Timers 2 and 3 Configurations

Item	Configuration
Timer register	8-bit counter n (TMn)
Register	8-bit compare register n (CRn)
Timer output	2 (TIO _n)
Control register	Timer clock select register n (TCLn) 8-bit timer mode control register n (TMCn)

Remark n = 2, 3

(1) 8-bit counter n (TMn: n = 2, 3)

TMn is an 8-bit read-only register which counts the count pulses.

The counter is incremented in synchronization with the rising edge of the count clock. When count value is read during operation, count clock input is temporary stopped, and then the count value is read. In the following situations, the count value is set to 00H.

<1> $\overline{\text{RESET}}$ input

<2> Clear TCE_n

<3> Match between TMn and CRn in clear and start made with match between TMn and CRn

Remark n = 2, 3

(2) 8-bit compare register n (CRn: n = 2, 3)

The value set in the CRn is constantly compared with the 8-bit counter n (TMn) count value, and an interrupt request (INTTMn) is generated if they match (except PWM mode).

It is possible to rewrite the value of CRn within 00H to FFH during count operation.

Remark n = 2, 3

9.3 8-Bit Timer/Event Counters 2 and 3 Control Registers

The following two types of registers are used to control timers 2 and 3.

- Timer clock select register n (TCLn)
- 8-bit timer mode control register n (TMCn)

n = 2, 3

(1) Timer clock select register n (TCLn: n = 2, 3)

This register sets count clocks of timers 2 and 3.

TCLn is set with an 8-bit memory manipulation instruction.

RESET input sets to 00H.

Figure 9-3. Timer Clock Select Register 2 (TCL2) Format

Address: FF74H After Reset: 00H R/W

Symbol	7	6	5	4	3	2	1	0
TCL2	0	0	0	0	0	TCL22	TCL21	TCL20

TCL22	TCL21	TCL20	Count Clock Selection
0	0	0	TIO2 Falling edge
0	0	1	TIO2 Rising edge
0	1	0	$f_x/2^3$ (1.04 MHz)
0	1	1	$f_x/2^5$ (261 kHz)
1	0	0	$f_x/2^7$ (65.4 kHz)
1	0	1	$f_x/2^8$ (32.7 kHz)
1	1	0	$f_x/2^9$ (16.3 kHz)
1	1	1	$f_x/2^{11}$ (4.09 kHz)

- Cautions**
1. When rewriting TCL2 to other data, stop the timer operation beforehand.
 2. Set bits 3 to 7 to 0.

- Remarks**
1. f_x : Main system clock oscillation frequency
 2. Figures in parentheses apply to operation with $f_x = 8.38$ MHz

Figure 9-4. Timer Clock Select Register 3 (TCL3) Format

Address: FF75H After Reset: 00H R/W

Symbol	7	6	5	4	3	2	1	0
TCL3	0	0	0	0	0	TCL32	TCL31	TCL30

TCL32	TCL31	TCL30	Count Clock Selection
0	0	0	TIO3 Falling edge
0	0	1	TIO3 Rising edge
0	1	0	$f_x/2^4$ (523 kHz)
0	1	1	$f_x/2^6$ (130 kHz)
1	0	0	$f_x/2^7$ (65.4 kHz)
1	0	1	$f_x/2^8$ (32.7 kHz)
1	1	0	$f_x/2^{10}$ (8.18 kHz)
1	1	1	$f_x/2^{12}$ (2.04 kHz)

- Cautions**
1. When rewriting TCL3 to other data, stop the timer operation beforehand.
 2. Set bits 3 to 7 to 0.

- Remarks**
1. f_x : Main system clock oscillation frequency
 2. Figures in parentheses apply to operation with $f_x = 8.38$ MHz

(2) 8-bit timer mode control register n (TMCn: n = 2, 3)

TMCn is a register which sets up the following five types.

- <1> 8-bit counter n (TMn) count operation control
- <2> 8-bit counter n (TMn) operating mode selection
- <3> Timer output F/F (flip flop) status setting
- <4> Active level selection in timer F/F control or PWM (free-running) mode.
- <5> Timer output control

TMCn is set with a 1-bit or 8-bit memory manipulation instruction.

RESET input sets to 04H.

Figure 9-5 shows TMCn format.

Figure 9-5. 8-Bit Timer Mode Control Register n (TMCn) Format

Address: FF77H (TMC2) FF78H (TMC3) After Reset: 04H R/W

Symbol 7 6 5 4 3 2 1 0

TMCn	TCEn	TMCn6	0	0	LVSn	LVRn	TMCn1	TOEn
------	------	-------	---	---	------	------	-------	------

TCEn	TM2, TM3 Count Operation Control
0	After clearing counter to 0, count operation disabled (prescaler disabled)
1	Count operation start

TMCn6	TM2, TM3 Operating Mode Selection
0	Clear and start mode by matching between TMn and CRn
1	PWM (Free-running) mode

LVSn	LVRn	Timer Output F/F Status Setting
0	0	No change
0	1	Timer output F/F reset (to 0)
1	0	Timer output F/F set (to 1)
1	1	Setting prohibited

TMCn1	In Other Modes (TMCn6 = 0)	In PWM Mode (TMCn6 = 1)
	Timer F/F Control	Active Level Selection
0	Inversion operation disabled	Active high
1	Inversion operation enabled	Active low

TOEn	Timer Output Control
0	Output disabled (Port mode)
1	Output enabled

- Cautions**
1. Set bit 4 and bit 5 to 0.
 2. Bit 2 and bit 3 are write-only.

- Remarks**
1. In PWM mode, PWM output will be inactive because of TCEn = 0.
 2. If LVSn and LVRn are read after data is set, they will be 0.
 3. n = 2, 3

9.4 8-Bit Timer/Event Counters 2 and 3 Operations

9.4.1 8-bit interval timer operation

The 8-bit timer/event counters operate as interval timers which generate interrupt requests repeatedly at intervals of the count value preset to 8-bit compare register n (CRn).

When the count values of the 8-bit counter n (TMn) match the values set to CRn, counting continues with the TMn values cleared to 0 and the interrupt request signal (INTTMn) is generated.

Count clock of the TMn can be selected with bits 0 to 2 (TCLn0 to TCLn2) of the timer clock select register n (TCLn).

[Setting]

<1> Set the registers.

- TCLn : Select count clock.
- CRn : Compare value
- TMCn : Select clear and start mode by match of TMn and CRn.
(TMCn = 0000xxx0B x = don't care)

<2> After TCEn = 1 is set, count operation starts.

<3> If the values of TMn and CRn match, the INTTMn is generated and TMn is cleared to 00H.

<4> INTTMn generates repeatedly at the same interval. Set TCEn to 0 to stop count operation.

Remark n = 2, 3

Figure 9-6. Interval Timer Operation Timings (1/3)

(a) Basic operation

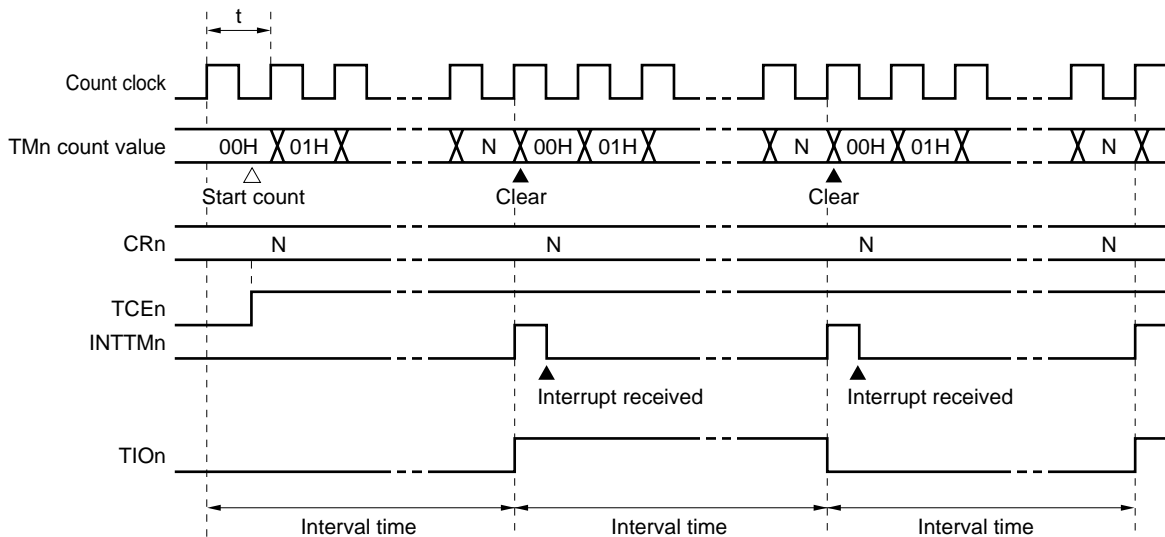

- Remarks**
1. Interval time = $(N + 1) \times t$: N = 00H to FFH
 2. n = 2, 3

Figure 9-6. Interval Timer Operation Timings (2/3)

(b) When CRn = 00H

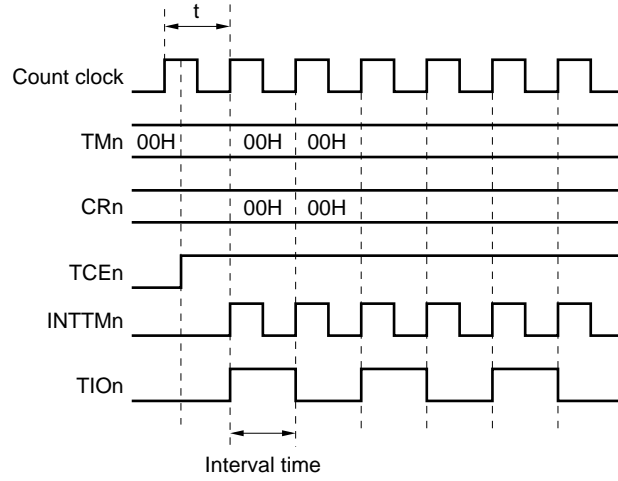

(c) When CRn = FFH

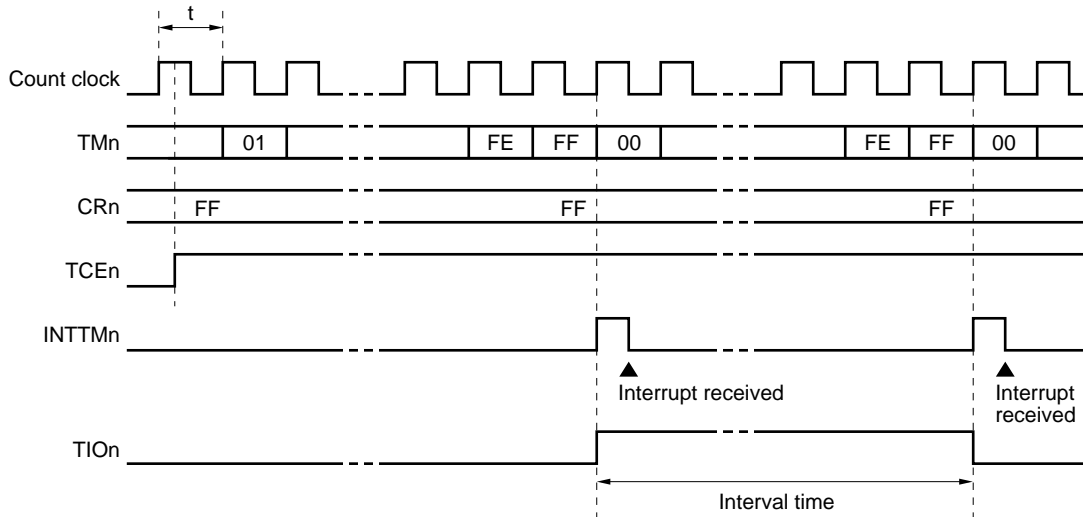

n = 2, 3

Figure 9-6. Interval Timer Operation Timings (3/3)

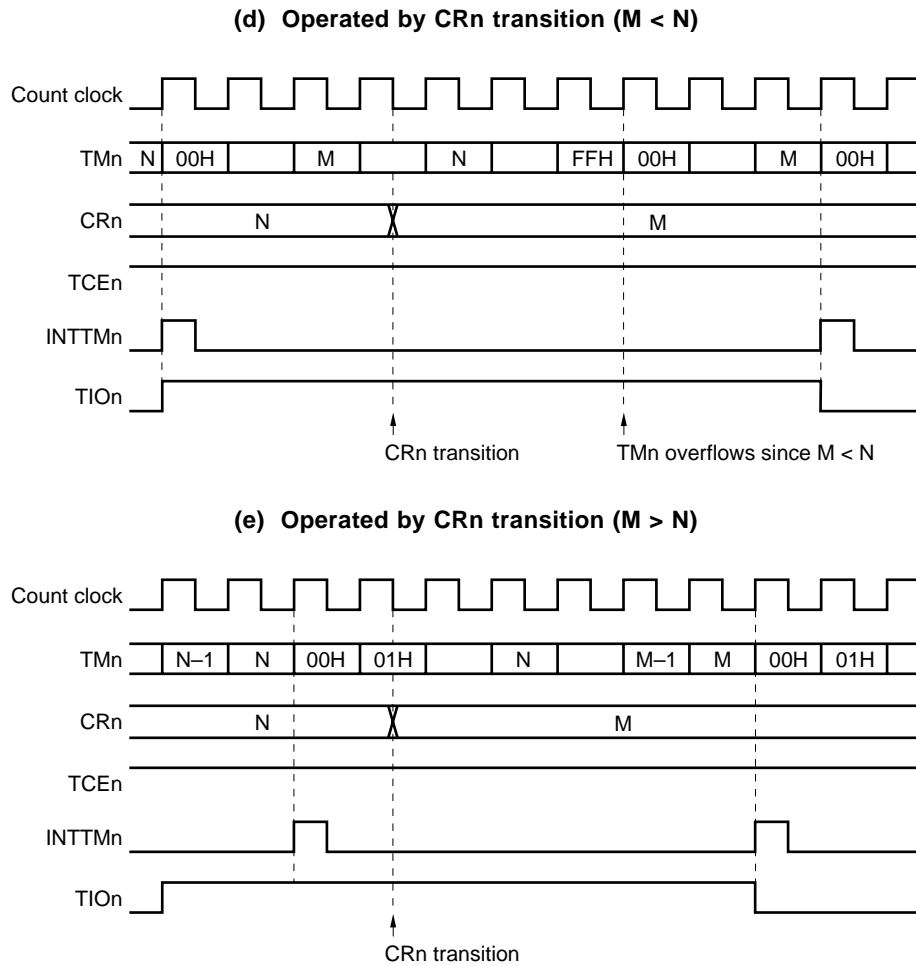

n = 2, 3

9.4.2 External event counter operation

The external event counter counts the number of external clock pulses to be input to the TIO_n.

TM_n is incremented each time the valid edge specified with the timer clock select register n (TCL_n) is input. Either the rising or falling edge can be selected.

When the TM_n counted values match the values of 8-bit compare register n (CR_n), TM_n is cleared to 0 and the interrupt request signal (INTTM_n) is generated.

Whenever the TM_n value matches the value of CR_n, INTTM_n is generated.

Remark n = 2, 3

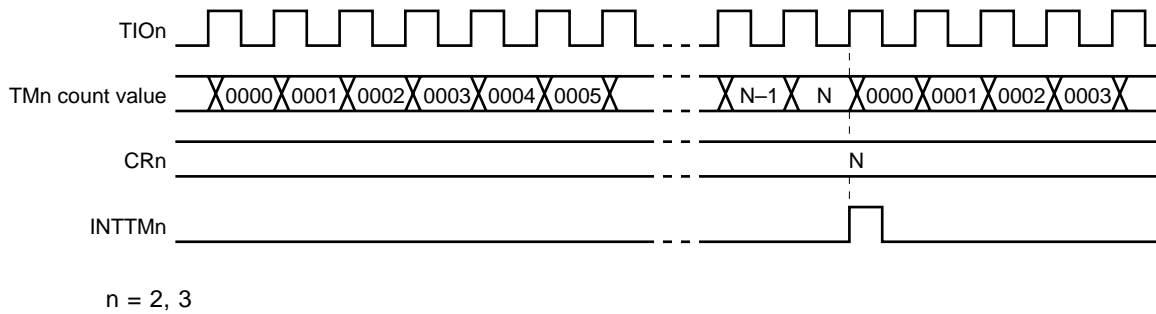
Figure 9-7. External Event Counter Operation Timings (with Rising Edge Specified)**9.4.3 Square-wave output operation (8-bit resolution)**

A square wave with any selected frequency is output at intervals of the value preset to 8-bit compare register n (CRn).

TIO pin output status is inverted at intervals of the count value preset to CRn by setting bit 0 (TOEn) of 8-bit timer mode control register n (TMCn) to 1. This enables a square wave with any selected frequency to be output (duty = 50%).

[Setting]

<1> Set each register.

- Set port latch and port mode register to 0.
- TCLn: Select count clock
- CRn: compare value
- TMCn: Clear and start mode by match of TMn and CRn

LVS _n	LVR _n	Timer Output F/F Status Setting
1	0	High-level output
0	1	Low-level output

Timer output F/F inversion enabled

Timer output enabled → TOEn = 1

<2> After TCEn = 1 is set, count operation starts.

<3> Timer output F/F is inverted by match of TMn and CRn. After INTTMn is generated, TMn is cleared to 00H.

<4> Timer output F/F is inverted at the same interval and square wave is output from TIO_n.

Remark n = 2, 3

9.4.4 8-bit PWM output operation

8-bit timer/event counters operate as PWM output when bit 6 (TMCn6) of 8-bit timer mode control register n (TMCn) is set to 1.

The duty rate pulse determined by the value set to 8-bit compare register n (CRn) is output from TIO_n.

Set the active level width of PWM pulse to CR_n, and the active level can be selected with bit 1 (TMCn1) of TMCn.

Count clock can be selected with bit 0 to bit 2 (TCLn0 to TCLn2) of timer clock select register n (TCLn).

PWM output enable/disable can be selected with bit 0 (TOEn) of TMCn.

Caution Rewrite of CR_n in PWM mode is allowed only once in a cycle.

Remark n = 2, 3

(1) PWM output basic operation

[Setting]

- <1> Set port latch (P43, P44) and port mode register 4 (PM43, PM44) to 0.
- <2> Set active level width with 8-bit compare register (CR_n).
- <3> Select count clock with timer clock select register n (TCL_n).
- <4> Set active level with bit 1 (TMCn1) of TMCn.
- <5> Count operation starts when bit 7 (TCEn) of TMCn is set to 1.
Set TCEn to 0 to stop count operation.

[PWM output operation]

- <1> PWM output (output from TIO_n) outputs inactive level after count operation starts until overflow is generated.
- <2> When overflow is generated, the active level set in <1> of setting is output.
The active level is output until CR_n matches the count value of 8-bit counter n (TM_n).
- <3> After the CR_n matches the count value, PWM output outputs the inactive level again until overflow is generated.
- <4> PWM output operation <2> and <3> are repeated until the count operation stops.
- <5> When the count operation is stopped with TCEn = 0, PWM output changes to inactive level.

Remark n = 2, 3

(a) PWM output basic operation

Figure 9-8. PWM Output Operation Timing

(i) Basic operation (active level = H)

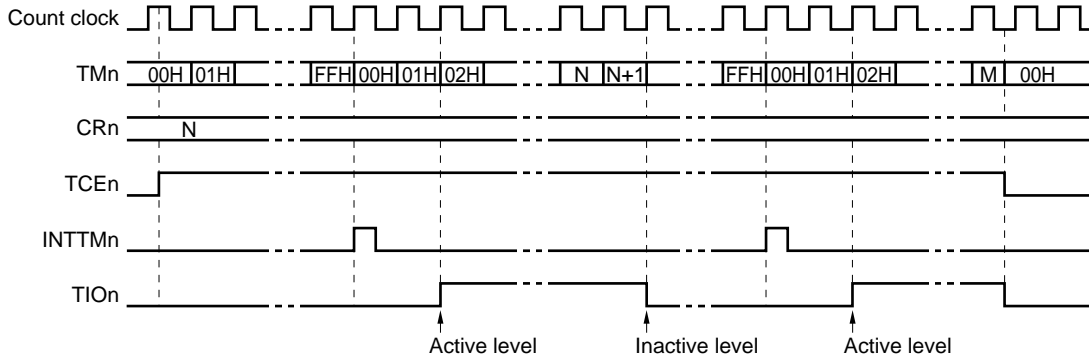

(ii) CRn = 0

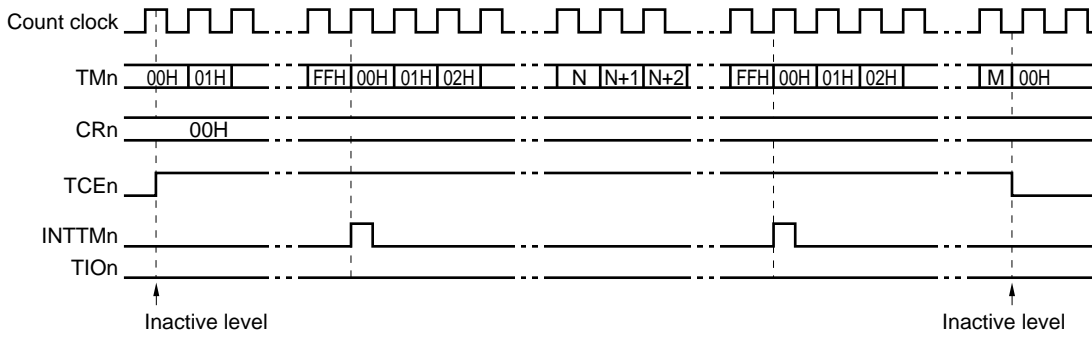

(iii) CRn = FFH

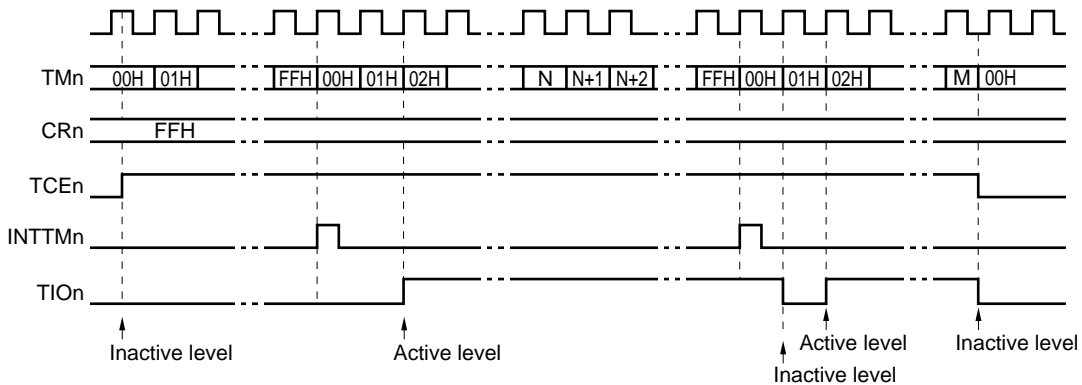

n = 2, 3

(b) Operation by change of CRn

Figure 9-9. Timing of Operation by Change of CRn

(i) Change of CRn value to N to M before overflow of TMn

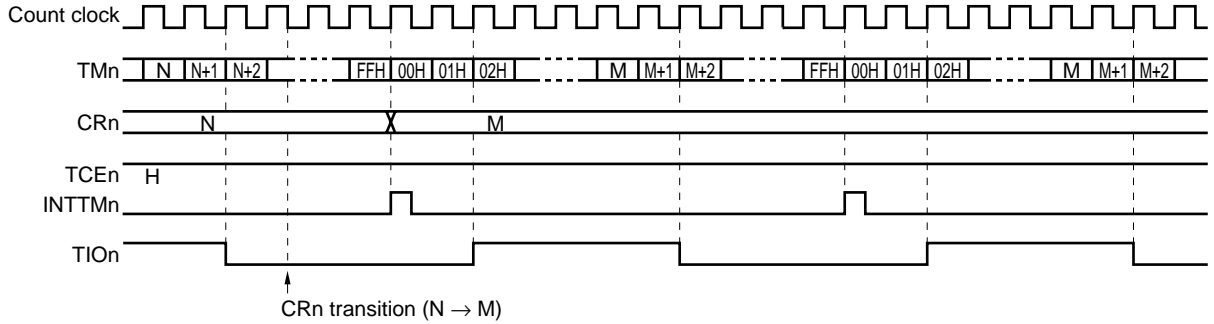

(ii) Change of CRn value to N to M after overflow of TMn

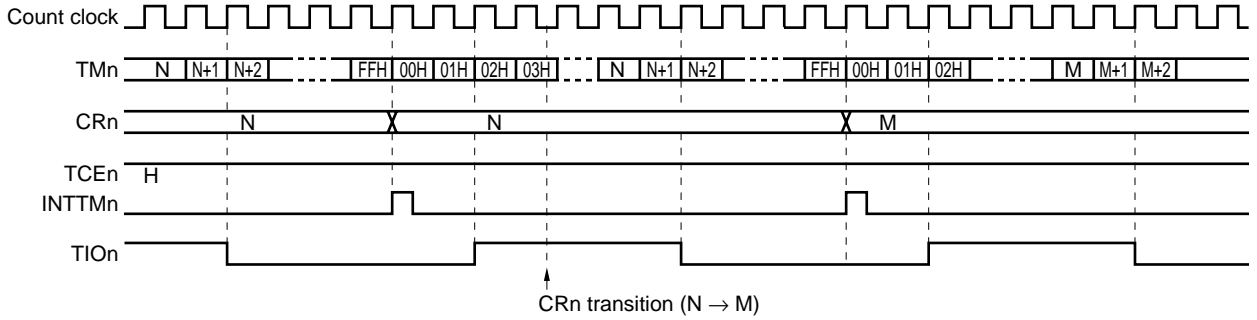

(iii) Change of CRn value to N to M between two clocks (00H and 01H) after overflow of TMn

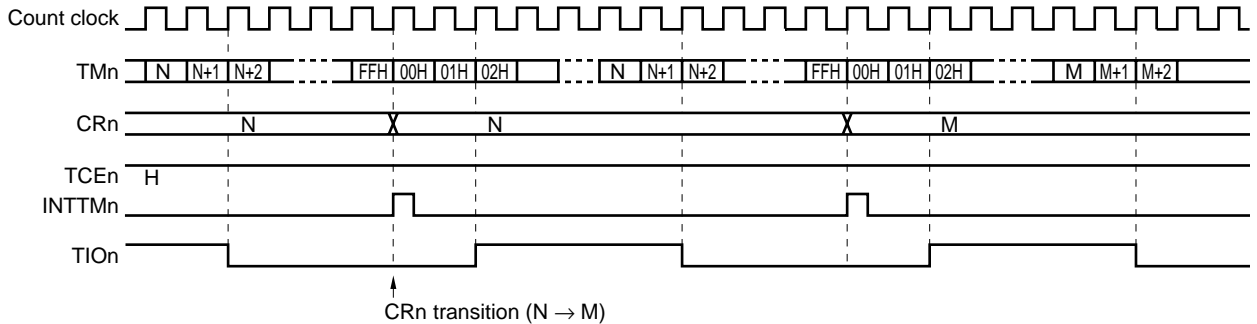

n = 2, 3

9.5 8-Bit Timer/Event Counters 2 and 3 Cautions

(1) Timer start errors

An error with a maximum of one clock may occur concerning the time required for a match signal to be generated after timer start. This is because 8-bit counter n (TM_n) is started asynchronously with the count pulse.

Figure 9-10. Timer n Start Timing

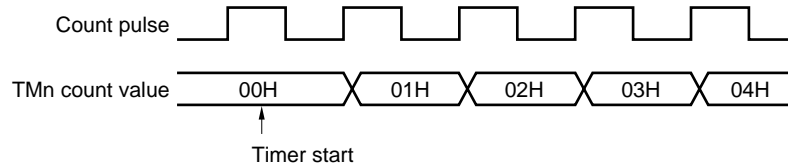

$n = 2, 3$

(2) Operation after compare register change during timer count operation

If the values after the 8-bit compare register n (CR_n) is changed are smaller than the value of 8-bit timer register n (TM_n), TM_n continues counting, overflows and then restarts counting from 0. Thus, if the value (M) after CR_n change is smaller than value (N) before the change, it is necessary to restart the timer after changing CR_n .

Figure 9-11. Timing after Compare Register Change during Timer Count Operation

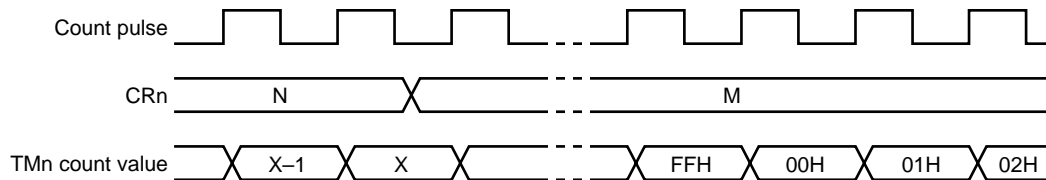

- Remarks**
1. $N > X > M$
 2. $n = 2, 3$

Caution Except when the TIO_n input is selected, always set $TCE_n = 0$ before setting the STOP state.

Remark $n = 2, 3$

(3) TM_n ($n = 2, 3$) reading during timer operation

When TM_n is read during operation, choose a select clock which has a longer high/low level wave because the select clock is stopped temporarily.

CHAPTER 10 WATCH TIMER

10.1 Watch Timer Functions

The watch timer has the following functions.

- Watch timer
- Interval timer

The watch timer and the interval timer can be used simultaneously.

Figure 10-1 shows watch timer block diagram.

Figure 10-1. Watch Timer Block Diagram

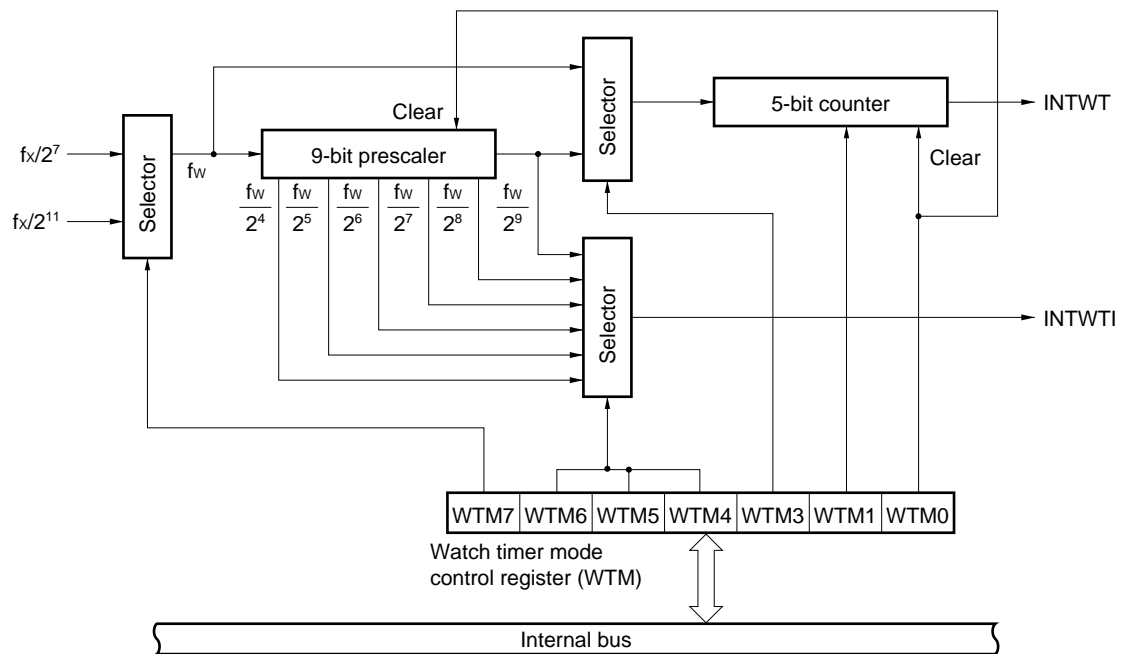

(1) Watch timer

When the main system clock is used, interrupt requests (INTWT) are generated at 0.25 second (at $f_x = 8.38$ -MHz operation) intervals.

(2) Interval timer

Interrupt requests (INTWT) are generated at the preset time interval.

Table 10-1. Interval Timer Interval Time

Interval Time	When Operated at $f_x = 8.38$ MHz
$2^{12} \times 1/f_x$	489 μ s
$2^{13} \times 1/f_x$	978 μ s
$2^{14} \times 1/f_x$	1.96 ms
$2^{15} \times 1/f_x$	3.91 ms
$2^{16} \times 1/f_x$	7.82 ms
$2^{17} \times 1/f_x$	15.65 ms

Remark f_x : Main system clock oscillation frequency

10.2 Watch Timer Configuration

The watch timer consists of the following hardware.

Table 10-2. Watch Timer Configuration

Item	Configuration
Counter	5 bits \times 1
Prescaler	9 bits \times 1
Control register	Watch timer mode control register (WTM)

10.3 Watch Timer Control Register

The watch timer mode control register (WTM) is used to control the watch timer.

- **Watch timer mode control register (WTM)**

This register sets the watch timer count clock, operation enable/disable, prescaler interval time and 5-bit counter operation control.

WTM is set with an 8-bit memory manipulation instruction.

$\overline{\text{RESET}}$ input clears WTM to 00H.

Figure 10-2. Watch Timer Mode Control Register (WTM) Format

Address: FF41H After Reset: 00H R/W

Symbol	7	6	5	4	3	2	1	0
WTM	WTM7	WTM6	WTM5	WTM4	WTM3	0	WTM1	WTM0

WTM7	Watch Timer Count Clock Selection
0	$f_x/2^7$ (65.4 kHz)
1	$f_x/2^{11}$ (4.09 kHz)

WTM6	WTM5	WTM4	Prescaler Interval Time Selection
0	0	0	$2^4/f_w$ (3.91 ms)
0	0	1	$2^5/f_w$ (7.82 ms)
0	1	0	$2^6/f_w$ (15.6 ms)
0	1	1	$2^7/f_w$ (31.2 ms)
1	0	0	$2^8/f_w$ (62.5 ms)
1	0	1	$2^9/f_w$ (125 ms)
Other than above			Setting prohibited

WTM3	Watch Flag Set Time Selection
0	Normal operating mode (flag set at $f_w/2^{14}$)
1	Fast feed operating mode (flag set at $f_w/2^5$)

WTM1	5-bit Counter Operation Control
0	Clear after operation stop
1	Start

WTM0	Watch Timer Operation Control
0	Operation stop (clear both prescaler and timer)
1	Operation enable

- Remarks**
1. f_w : Watch timer clock frequency ($f_x/2^7$ or $f_x/2^{11}$)
 2. f_x : Main system clock oscillation frequency
 3. Figures in parentheses apply to operation with $f_x = 8.38$ MHz, $f_w = 4.09$ kHz.

10.4 Watch Timer Operations

10.4.1 Watch timer operation

When the 8.38-MHz main system clock is used, the timer operates as a watch timer with a 0.25-second interval. The watch timer generates interrupt requests at a constant time interval.

When bit 0 (WTM0) and bit 1 (WTM1) of the watch timer mode control register are set to 1, the count operation starts. When set to 0, the 5-bit counter is cleared and the count operation stops.

For simultaneous operation of the interval timer, zero-second start can be set only for the watch timer by setting WTM1 to 0. However, since the 9-bit prescaler is not cleared the first overflow of the watch timer (INTWWT) after zero-second start may include an error of up to $2^9 \times 1/f_w$.

10.4.2 Interval timer operation

The watch timer operates as interval timer which generates interrupt request repeatedly at an interval of the preset count value.

The interval time can be selected with bits 4 to 6 (WTM4 to WTM6) of the watch timer mode control register (WTM).

Table 10-3. Interval Timer Interval Time

WTM6	WTM5	WTM4	Interval Time	When Operated at $f_w = 65.4 \text{ kHz}$	When Operated at $f_w = 4.09 \text{ kHz}$
0	0	0	$2^4 \times 1/f_w$	244 μs	3.91 ms
0	0	1	$2^5 \times 1/f_w$	489 μs	7.81 ms
0	1	0	$2^6 \times 1/f_w$	978 μs	15.6 ms
0	1	1	$2^7 \times 1/f_w$	1.96 ms	31.3 ms
1	0	0	$2^8 \times 1/f_w$	3.91 ms	62.5 ms
1	0	1	$2^9 \times 1/f_w$	7.82 ms	125 ms
Other than above			Setting prohibited		

Remark f_w : Watch timer clock frequency

Figure 10-3. Operation Timing of Watch Timer/Interval Timer

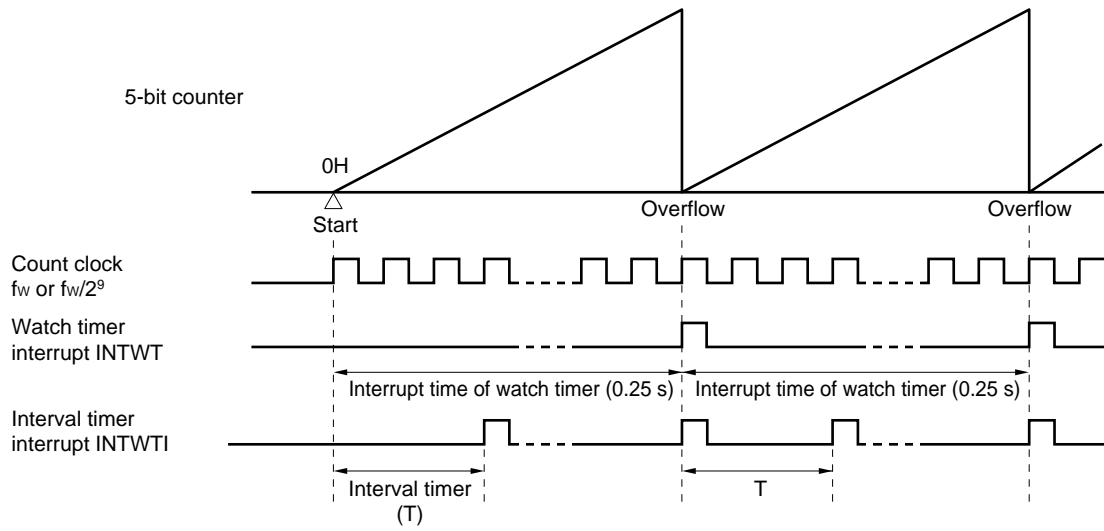

Remark f_w : Watch timer clock frequency
 () : $f_w = 4.09 \text{ kHz}$ ($f_x = 8.38 \text{ MHz}$)

[MEMO]

CHAPTER 11 WATCHDOG TIMER

11.1 Watchdog Timer Functions

The watchdog timer has the following functions.

- Watchdog timer
- Interval timer

Caution Select the watchdog timer mode or the interval timer mode with the watchdog timer mode register (WDTM).

Figure 11-1 shows the watchdog timer block diagram.

Figure 11-1. Watchdog Timer Block Diagram

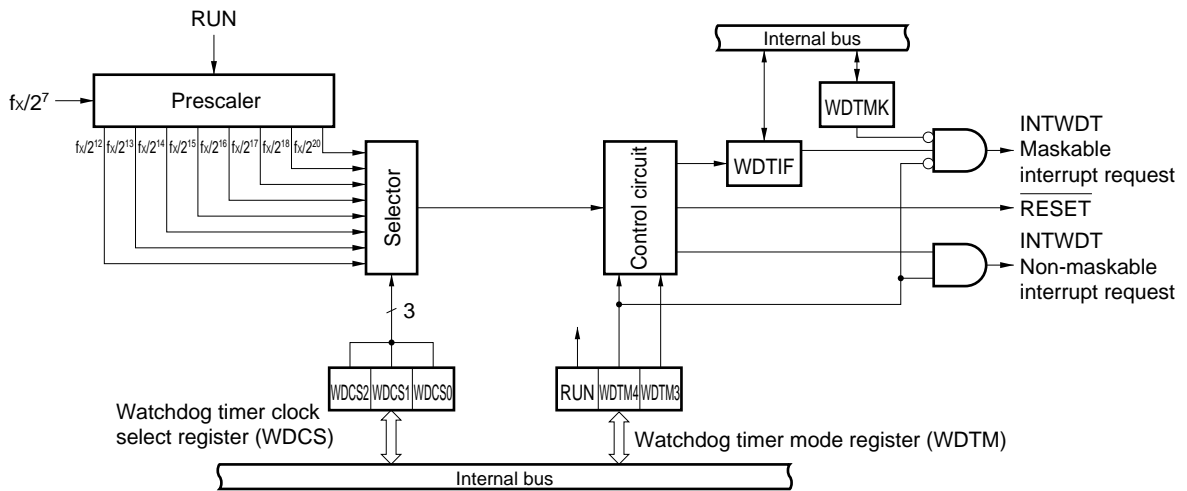

(1) Watchdog timer mode

A runaway is detected. Upon detection of the runaway, a non-maskable interrupt request or $\overline{\text{RESET}}$ can be generated.

Table 11-1. Watchdog Timer Runaway Detection Time

Runaway Detection Time
$2^{12} \times 1/f_x$ (489 μs)
$2^{13} \times 1/f_x$ (978 μs)
$2^{14} \times 1/f_x$ (1.96 ms)
$2^{15} \times 1/f_x$ (3.91 ms)
$2^{16} \times 1/f_x$ (7.82 ms)
$2^{17} \times 1/f_x$ (15.6 ms)
$2^{18} \times 1/f_x$ (31.3 ms)
$2^{20} \times 1/f_x$ (125 ms)

- Remarks**
1. f_x : Main system clock oscillation frequency
 2. Figures in parentheses apply to operation with $f_x = 8.38$ MHz.

(2) Interval timer mode

Interrupt requests are generated at preset time intervals.

Table 11-2. Interval Time

Interval Time
$2^{12} \times 1/f_x$ (489 μs)
$2^{13} \times 1/f_x$ (978 μs)
$2^{14} \times 1/f_x$ (1.96 ms)
$2^{15} \times 1/f_x$ (3.91 ms)
$2^{16} \times 1/f_x$ (7.82 ms)
$2^{17} \times 1/f_x$ (15.6 ms)
$2^{18} \times 1/f_x$ (31.3 ms)
$2^{20} \times 1/f_x$ (125 ms)

- Remarks**
1. f_x : Main system clock oscillation frequency
 2. Figures in parentheses apply to operation with $f_x = 8.38$ MHz.

11.2 Watchdog Timer Configuration

The watchdog timer consists of the following hardware.

Table 11-3. Watchdog Timer Configuration

Item	Configuration
Control register	Watchdog timer clock select register (WDCS) Watchdog timer mode register (WDTM)

11.3 Watchdog Timer Control Registers

The following two types of registers are used to control the watchdog timer.

- Watchdog timer clock select register (WDCS)
- Watchdog timer mode register (WDTM)

(1) Watchdog timer clock select register (WDCS)

This register sets overflow time of the watchdog timer and the interval timer.

WDCS is set with an 8-bit memory manipulation instruction.

$\overline{\text{RESET}}$ input clears WDCS to 00H.

Figure 11-2. Watchdog Timer Clock Select Register (WDCS) Format

Address: FF42H After Reset: 00H R/W

Symbol	7	6	5	4	3	2	1	0
WDCS	0	0	0	0	0	WDCS2	WDCS1	WDCS0

WDCS2	WDCS1	WDCS0	Overflow Time of Watchdog Timer/Interval Timer
0	0	0	$2^{12}/f_x$ (489 μ s)
0	0	1	$2^{13}/f_x$ (978 μ s)
0	1	0	$2^{14}/f_x$ (1.96 ms)
0	1	1	$2^{15}/f_x$ (3.91 ms)
1	0	0	$2^{16}/f_x$ (7.82 ms)
1	0	1	$2^{17}/f_x$ (15.6 ms)
1	1	0	$2^{18}/f_x$ (31.3 ms)
1	1	1	$2^{20}/f_x$ (125 ms)

- Cautions**
1. When rewriting WDCS to other data, stop the timer operation beforehand.
 2. Bits 3 to 7 must be set to 0.

- Remarks**
1. f_x : Main system clock oscillation frequency
 2. Figures in parentheses apply to operation with $f_x = 8.38$ MHz

(2) Watchdog timer mode register (WDTM)

This register sets the watchdog timer operating mode and enables/disables counting.

WDTM is set with a 1-bit or 8-bit memory manipulation instruction.

$\overline{\text{RESET}}$ input clears WDTM to 00H.

Figure 11-3. Watchdog Timer Mode Register (WDTM) Format

Address: FFF9H After Reset: 00H R/W

Symbol	7	6	5	4	3	2	1	0
WDTM	RUN	0	0	WDTM4	WDTM3	0	0	0

RUN	Watchdog Timer Operation Mode Selection Note 1
0	Count stop
1	Counter is cleared and counting starts

WDTM4	WDTM3	Watchdog Timer Operation Mode Selection Note 2
0	×	Interval timer mode (Maskable interrupt request occurs upon generation of an overflow)
1	0	Watchdog timer mode 1 (Non-maskable interrupt request occurs upon generation of an overflow)
1	1	Watchdog timer mode 2 (Reset operation is activated upon generation of an overflow)

- Notes**
- Once set to 1, RUN cannot be cleared to 0 by software.
Thus, once counting starts, it can only be stopped by $\overline{\text{RESET}}$ input.
 - Once set to 1, WDTM3 and WDTM4 cannot be cleared to 0 by software.

- Cautions**
- When 1 is set in RUN so that the watchdog timer is cleared, the actual overflow time is up to 0.5% shorter than the time set by the watchdog timer clock select register.
 - To use watchdog timer modes 1 and 2, make sure that the interrupt request flag (WDTIF) is 0, and then set WDTM4 to 1.
If WDTM4 is set to 1 when WDTIF is 1, the non-maskable interrupt request occurs, regardless of the contents of WDTM3.

Remark ×: don't care

11.4 Watchdog Timer Operations

11.4.1 Watchdog timer operation

When bit 4 (WDTM4) of the watchdog timer mode register (WDTM) is set to 1, the watchdog timer is operated to detect any runaways.

Watchdog timer starts by setting bit 7 (RUN) of WDTM to 1. After the watchdog timer is started, set RUN to 1 within the set runaway time interval. The watchdog timer can be cleared and counting is started.

If RUN is not set to 1 and the runaway detection time is past, system reset or a non-maskable interrupt request is generated according to the WDTM bit 3 (WDTM3) value.

The watchdog timer continues operating in the HALT mode but it stops in the STOP mode. Thus, set RUN to 1 before the STOP mode is set, clear the watchdog timer and then execute the STOP instruction.

Caution The actual runaway detection time may be shorter than the set time by a maximum of 0.5%.

Table 11-4. Watchdog Timer Runaway Detection Time

Runaway Detection Time
$2^{12} \times 1/f_x$ (489 μ s)
$2^{13} \times 1/f_x$ (978 μ s)
$2^{14} \times 1/f_x$ (1.96 ms)
$2^{15} \times 1/f_x$ (3.91 ms)
$2^{16} \times 1/f_x$ (7.82 ms)
$2^{17} \times 1/f_x$ (15.6 ms)
$2^{18} \times 1/f_x$ (31.3 ms)
$2^{20} \times 1/f_x$ (125 ms)

- Remarks**
1. f_x : Main system clock oscillation frequency
 2. Figures in parentheses apply to operation with $f_x = 8.38$ MHz.

11.4.2 Interval timer operation

The watchdog timer operates as an interval timer which generates interrupt request repeatedly at an interval of the preset count value when bit 3 (WDTM3) and bit 4 (WDTM4) of the watchdog timer mode register (WDTM) are set to 1 and 0, respectively.

When the watchdog timer operates as interval timer, the interrupt mask flag (WDTMK) and priority specify flag (WDTPR) are validated and the maskable interrupt request (INTWDT) can be generated. Among maskable interrupts, the INTWDT default has the highest priority.

The interval timer continues operating in the HALT mode but it stops in STOP mode. Thus, set RUN to 1 before the STOP mode is set, clear the interval timer and then execute the STOP instruction.

- Cautions**
1. Once bit 4 (WDTM4) of WDTM is set to 1 (with the watchdog timer mode selected), the interval timer mode is not set unless $\overline{\text{RESET}}$ input is applied.
 2. The interval time just after setting with WDTM may be shorter than the set time by a maximum of 0.5%.

Table 11-5. Interval Timer Interval Time

Interval Time
$2^{12} \times 1/f_x$ (489 μs)
$2^{13} \times 1/f_x$ (978 μs)
$2^{14} \times 1/f_x$ (1.96 ms)
$2^{15} \times 1/f_x$ (3.91 ms)
$2^{16} \times 1/f_x$ (7.82 ms)
$2^{17} \times 1/f_x$ (15.6 ms)
$2^{18} \times 1/f_x$ (31.3 ms)
$2^{20} \times 1/f_x$ (125 ms)

- Remarks**
1. f_x : Main system clock oscillation frequency
 2. Figures in parentheses apply to operation with $f_x = 8.38$ MHz.

CHAPTER 12 CLOCK OUTPUT CONTROL CIRCUIT

12.1 Clock Output Control Circuit Functions

The clock output control circuit is intended for carrier output during remote controlled transmission and clock output for supply to peripheral LSIs. The clock selected with the clock output selection register (CKS) is output from the PCL/SGOA/P60 pin.

Figure 12-1 shows the clock output control circuit (CKU) block diagram.

Figure 12-1. Clock Output Control Circuit Block Diagram

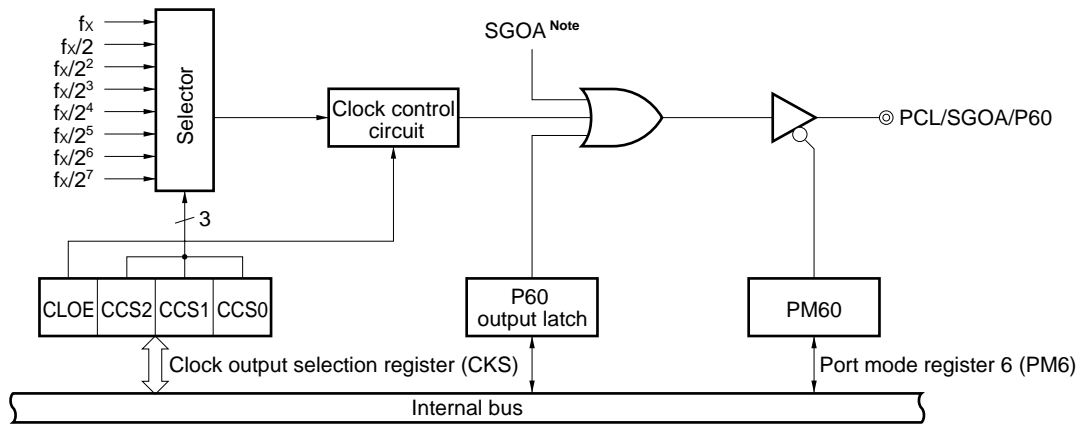

Note SGOA: Sound generator amplitude signal

12.2 Clock Output Control Circuit Configuration

The clock output control circuit (CKU) consists of the following hardware.

Table 12-1. Clock Output Control Circuit Configuration

Item	Configuration
Control register	Clock output selection register (CKS) Port mode register 6 (PM6)

12.3 Clock Output Control Circuit Control Registers

The following two types of registers are used to control the CKU.

- Clock output selection register (CKS)
- Port mode register 6 (PM6)

(1) Clock output selection register (CKS)

This register sets output clock.

CKS is set with a 1-bit or 8-bit memory manipulation instruction.

$\overline{\text{RESET}}$ input clears CKS to 00H.

Figure 12-2. Clock Output Selection Register (CKS) Format

Address: FF40H After Reset: 00H R/W

Symbol	7	6	5	4	3	2	1	0
CKS	0	0	0	CLOE	0	CCS2	CCS1	CCS0

CLOE	PCL Output Enable/Disable Specification
0	Stop clock division circuit operation.
1	Enable clock division circuit operation.

CCS2	CCS1	CCS0	PCL Output Clock Selection
0	0	0	f_x (8.38 MHz)
0	0	1	$f_x/2$ (4.19 MHz)
0	1	0	$f_x/2^2$ (2.09 MHz)
0	1	1	$f_x/2^3$ (1.04 MHz)
1	0	0	$f_x/2^4$ (524 kHz)
1	0	1	$f_x/2^5$ (262 kHz)
1	1	0	$f_x/2^6$ (131 kHz)
1	1	1	$f_x/2^7$ (65.5 kHz)

- Cautions**
1. When rewriting CKS to other data, stop the timer operation beforehand.
 2. Bit 3 and bits 5 to 7 must be set to 0.

- Remarks**
1. f_x = main system clock oscillation frequency
 2. Figures in parentheses apply to operation with $f_x = 8.38$ MHz.

(2) Port mode register 6 (PM6)

This register sets port 6 input/output in 1-bit units.

When using the P60/PCL/SOGA pin for clock output, set PM60 and the output latch of P60 to 0.

PM6 is set with a 1-bit or 8-bit memory manipulation instruction.

RESET input sets PM6 to FFH.

Figure 12-3. Port Mode Register 6 (PM6) Format

Address: FF26H After Reset: FFH R/W

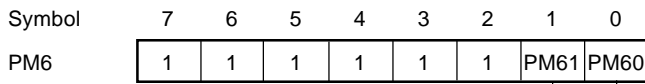

PM6n	P6n Pin Input/Output Mode Selection (n = 0 , 1)
0	Output mode (output buffer ON)
1	Input mode (output buffer OFF)

12.4 Clock Output Control Circuit Operation

12.4.1 Clock output operation

To output the clock pulse, follow the procedure described below.

- <1> Select the clock pulse output frequency with bits 0 to 3 (CCS0 to CCS3) of the clock output selection register (CKS) (clock pulse output in disabled status).
- <2> Set bit 3 (SGOB) of the sound generator control register (SGCR) to 1 (SGOF output in disabled status).
- <3> Set the P60 output latch to 0.
- <4> Set bit 0 (PM60) of port mode register 6 to 0 (set to output mode).
- <5> Set bit 4 (CLOE) of CKS to 1, and enable clock output.

Remark The clock output control circuit is designed not to output pulses with a small width during output enable/disable switching of the clock output. As shown in Figure 12-4, be sure to start output from the low period of the clock (marked with * in the figure below). When stopping output, do so after securing high level of the clock.

Figure 12-4. Remote Control Output Application Example

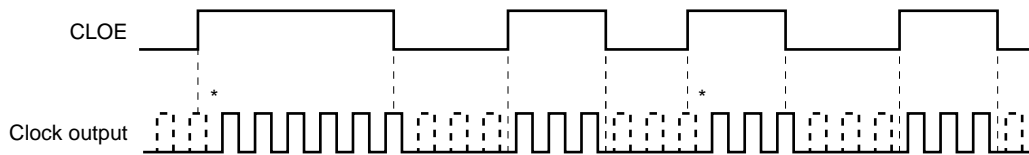

CHAPTER 13 A/D CONVERTER

13.1 A/D Converter Functions

The A/D converter is an 8-bit resolution converter that converts analog inputs into digital values. It can control up to 5 analog input channels (ANI0 to ANI4).

This A/D converter has the following functions:

(1) A/D conversion with 8-bit resolution

One channel of analog input is selected from ANI0 to ANI4, and A/D conversion is repeatedly executed with a resolution of 8 bits. Each time the conversion has been completed, interrupt request (INTAD) is generated.

(2) Power-fail detection function

This function is to detect a voltage drop in the battery of an automobile. The result of A/D conversion (value of the ADCR1 register) and the value of PFT register (PFT: power-fail compare threshold value register) are compared. If the condition for comparison is satisfied, INTAD is generated.

Figure 13-1. A/D Converter Block Diagram

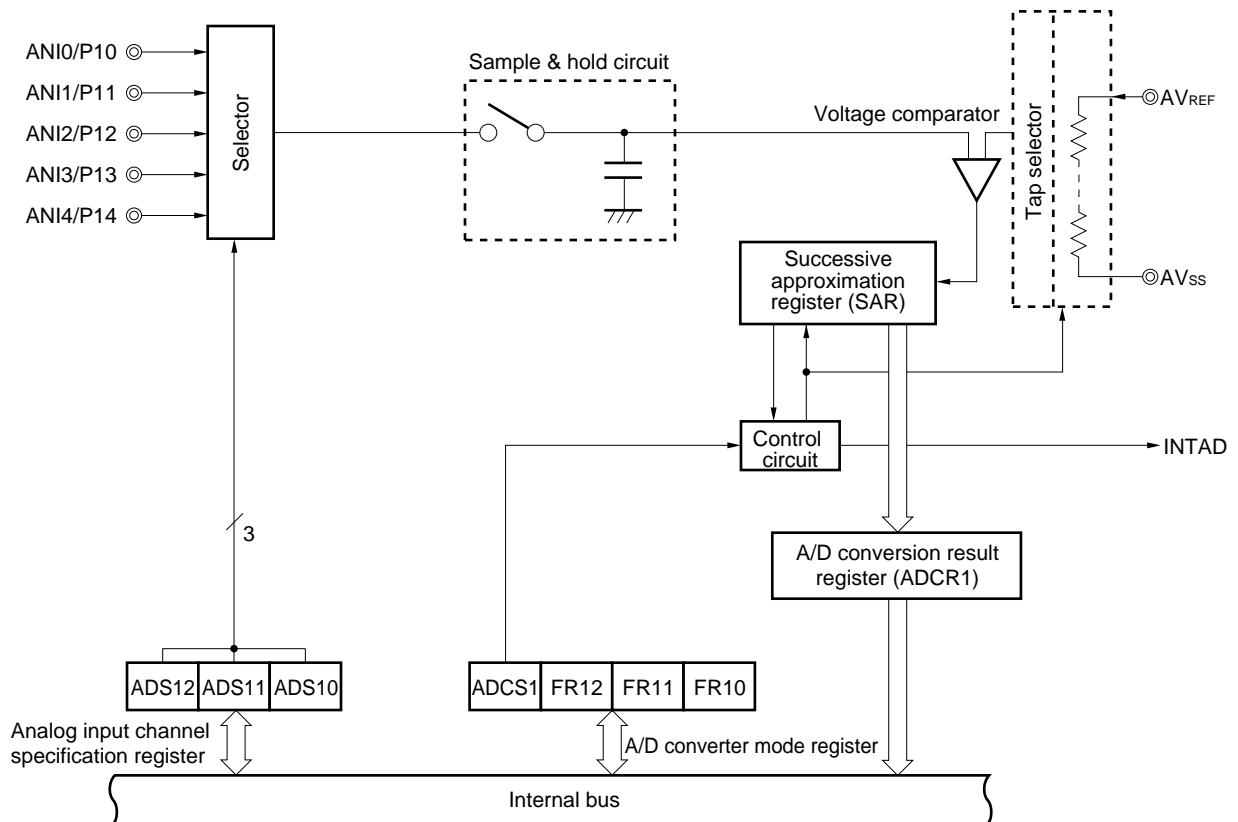
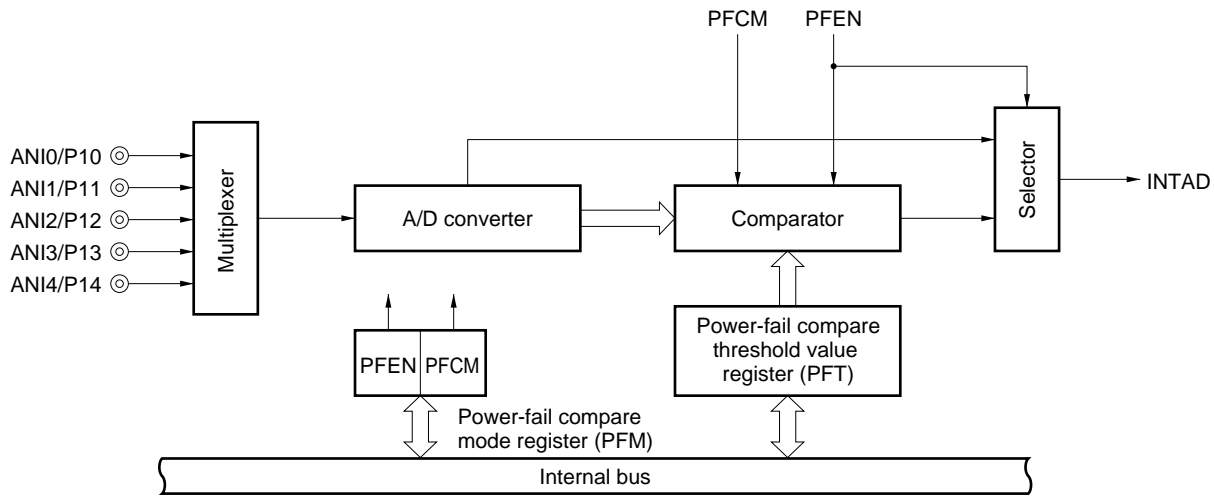

Figure 13-2. Power-Fail Detection Function Block Diagram



13.2 A/D Converter Configuration

A/D converter consists of the following hardware.

Table 13-1. A/D Converter Configuration

Item	Configuration
Analog input	5 channels (ANI0 to ANI4)
Register	Successive approximation register (SAR) A/D conversion result register (ADCR1)
Control register	A/D converter mode register (ADM1) Analog input channel specification register (ADS1) Power-fail compare mode register (PFM) Power-fail compare threshold value register (PFT)

(1) Successive approximation register (SAR)

This register compares the analog input voltage value to the voltage tap (compare voltage) value applied from the series resistor string, and holds the result from the most significant bit (MSB).

When up to the least significant bit (LSB) is set (end of A/D conversion), the SAR contents are transferred to the A/D conversion result register.

(2) A/D conversion result register (ADCR1)

This register holds the A/D conversion result. Each time A/D conversion ends, the conversion result is loaded from the successive approximation register.

ADCR1 is read with an 8-bit memory manipulation instruction.

$\overline{\text{RESET}}$ input clears ADCR1 to 00H.

Caution When write operation is executed to A/D converter mode register (ADM1) and analog input channel specification register (ADS1), the contents of ADCR1 are undefined. Read the conversion result before write operation is executed to ADM1, ADS1. If a timing other than the above is used, the correct conversion result may not be read.

(3) Sample & hold circuit

The sample & hold circuit samples each analog input sequentially applied from the input circuit, and sends it to the voltage comparator. This circuit holds the sampled analog input voltage value during A/D conversion.

(4) Voltage comparator

The voltage comparator compares the analog input to the series resistor string output voltage.

(5) Series resistor string

The series resistor string is in AV_{REF} to AV_{SS} , and generates a voltage to be compared to the analog input.

(6) ANI0 to ANI4 pins

These are five analog input pins to input analog signals to undergo A/D conversion to the A/D converter. ANI0 to ANI4 are alternate-function pins that can also be used for digital input.

Caution Use ANI0 to ANI4 input voltages within the specification range. If a voltage higher than AV_{REF} or lower than AV_{SS} is applied (even if within the absolute maximum rating range), the conversion value of that channel will be undefined and the conversion values of other channels may also be affected.

(7) AV_{REF} pin (Shared with AV_{DD} pin)

This pin inputs the A/D converter reference voltage.

This pin also functions as an analog power supply pin. Supply power to this pin when the A/D converter is used. It converts signals input to ANI0 to ANI4 into digital signals according to the voltage applied between AV_{REF} and AV_{SS} .

The current flowing in the series resistor string can be reduced by setting the voltage to be input to the AV_{REF} pin to AV_{SS} level in the standby mode.

(8) AV_{SS} pin

This is the GND potential pin of the A/D converter. Always keep it at the same potential as the V_{SS} pin even when not using the A/D converter.

13.3 A/D Converter Control Registers

The following 4 types of registers are used to control A/D converter.

- A/D converter mode register (ADM1)
- Analog input channel specification register (ADS1)
- Power-fail compare mode register (PFM)
- Power-fail compare threshold value register (PFT)

(1) A/D converter mode register (ADM1)

This register sets the conversion time for analog input to be A/D converted, conversion start/stop and external trigger. ADM1 is set with an 8-bit memory manipulation instruction.

$\overline{\text{RESET}}$ input clears ADM1 to 00H.

Figure 13-3. A/D Converter Mode Register (ADM1) Format

Address: FF80H After Reset: 00H R/W

Symbol	7	6	5	4	3	2	1	0
ADM1	ADCS1	0	FR12	FR11	FR10	0	0	0

ADCS1	A/D Conversion Operation Control
0	Stop conversion operation.
1	Enable conversion operation.

FR12	FR11	FR10	Conversion Time Selection Note
0	0	0	144/fx
0	0	1	120/fx
0	1	0	96/fx
1	0	0	288/fx
1	0	1	240/fx
1	1	0	192/fx
Other than above			Setting prohibited

Note Set so that the A/D conversion time is 19.1 μs or more.

Caution Bits 0 to 2 and bit 6 must be set to 0.

Remark fx: Main system clock oscillation frequency

(2) Analog input channel specification register (ADS1)

This register specifies the analog voltage input port for A/D conversion.

ADS1 is set with an 8-bit memory manipulation instruction.

$\overline{\text{RESET}}$ input clears ADS1 to 00H.

Figure 13-4. Analog Input Channel Specification Register (ADS1) Format

Address: FF81H After Reset: 00H R/W

Symbol	7	6	5	4	3	2	1	0
ADS1	0	0	0	0	0	ADS12	ADS11	ADS10

ADS12	ADS11	ADS10	Analog Input Channel Specification
0	0	0	ANI0
0	0	1	ANI1
0	1	0	ANI2
0	1	1	ANI3
1	0	0	ANI4
Other than above			Setting prohibited

Caution Bits 3 to 7 must be set to 0.

(3) Power-fail compare mode register (PFM)

The power-fail compare mode register (PFM) controls a comparison operation.

$\overline{\text{RESET}}$ input clears PFM to 00H.

Figure 13-5. Power-Fail Compare Mode Register (PFM) Format

Address: FF82H After Reset: 00H R/W

Symbol	7	6	5	4	3	2	1	0
PFM	PFEN	PFCM	0	0	0	0	0	0

PFEN	Enables Power-Fail Comparison
0	Disables power-fail comparison (used as normal A/D converter)
1	Enables power-fail comparison (used to detect power failure)

PFCM		Power-Fail Compare Mode Selection
0	$\text{ADCR1} \geq \text{PFT}$	Generates interrupt request signal INTAD
	$\text{ADCR1} < \text{PFT}$	Does not generate interrupt request signal INTAD
1	$\text{ADCR1} \geq \text{PFT}$	Does not generate interrupt request signal INTAD
	$\text{ADCR1} < \text{PFT}$	Generates interrupt request signal INTAD

Caution Bits 0 to 5 must be set to 0.

(4) Power-fail compare threshold value register (PFT)

The power-fail compare threshold value register (PFT) sets a threshold value against which the result of A/D conversion is to be compared.

PFT is set with an 8-bit memory manipulation instruction.

$\overline{\text{RESET}}$ input clears PFT to 00H.

13.4 A/D Converter Operations

13.4.1 Basic operations of A/D converter

- <1> Select one channel for A/D conversion with the analog input channel specification register (ADS1).
- <2> The voltage input to the selected analog input channel is sampled by the sample & hold circuit.
- <3> When sampling has been done for a certain time, the sample & hold circuit is placed in the hold state and the input analog voltage is held until the A/D conversion operation is ended.
- <4> Set bit 7 of the successive approximation register (SAR) so that the tap selector sets the series resistor string voltage tap to $(1/2) AV_{REF}$.
- <5> The voltage difference between the series resistor string voltage tap and analog input is compared with the voltage comparator. If the analog input is greater than $(1/2) AV_{REF}$, the MSB of SAR remains set. If the analog input is smaller than $(1/2) AV_{REF}$, the MSB is reset.
- <6> Next, bit 6 of SAR is automatically set, and the operation proceeds to the next comparison. The series resistor string voltage tap is selected according to the preset value of bit 7, as described below.
 - Bit 7 = 1: $(3/4) AV_{REF}$
 - Bit 7 = 0: $(1/4) AV_{REF}$The voltage tap and analog input voltage are compared and bit 6 of SAR is manipulated as follows.
 - Analog input voltage \geq Voltage tap: Bit 6 = 1
 - Analog input voltage $<$ Voltage tap: Bit 6 = 0
- <7> Comparison is continued in this way up to bit 0 of SAR.
- <8> Upon completion of the comparison of 8 bits, an effective digital result value remains in SAR, and the result value is transferred to and latched in the A/D conversion result register (ADCR1).
At the same time, the A/D conversion end interrupt request (INTAD) can also be generated.

Figure 13-6. Basic Operation of 8-Bit A/D Converter

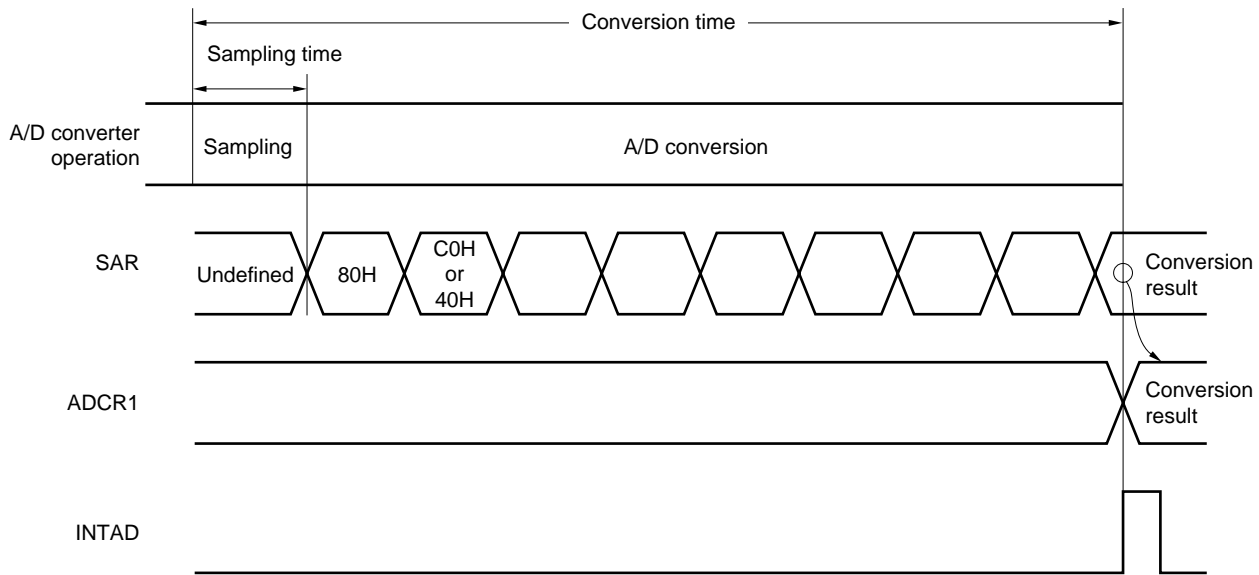

A/D conversion operations are performed continuously until bit 7 (ADCS1) of the A/D converter mode register (ADM1) is reset (to 0) by software.

If a write operation to the ADM1 and analog input channel specification register (ADS1) is performed during an A/D conversion operation, the conversion operation is initialized, and if the ADCS1 bit is set (to 1), conversion starts again from the beginning.

$\overline{\text{RESET}}$ input sets the A/D conversion result register (ADCR1) to 00H.

13.4.2 Input voltage and conversion results

The relation between the analog input voltage input to the analog input pins (ANI0 to ANI4) and the A/D conversion result (stored in the A/D conversion result register (ADCR1)) is shown by the following expression.

$$ADCR1 = \text{INT} \left(\frac{V_{\text{IN}}}{AV_{\text{REF}}} \times 256 + 0.5 \right)$$

or

$$(ADCR1 - 0.5) \times \frac{AV_{\text{REF}}}{256} \leq V_{\text{IN}} < (ADCR1 + 0.5) \times \frac{AV_{\text{REF}}}{256}$$

where, INT() : Function which returns integer part of value in parentheses

V_{IN} : Analog input voltage

AV_{REF} : AV_{REF} pin voltage

ADCR1 : A/D conversion result register (ADCR1) value

Figure 13-7 shows the relation between the analog input voltage and the A/D conversion result.

Figure 13-7. Relation between Analog Input Voltage and A/D Conversion Result

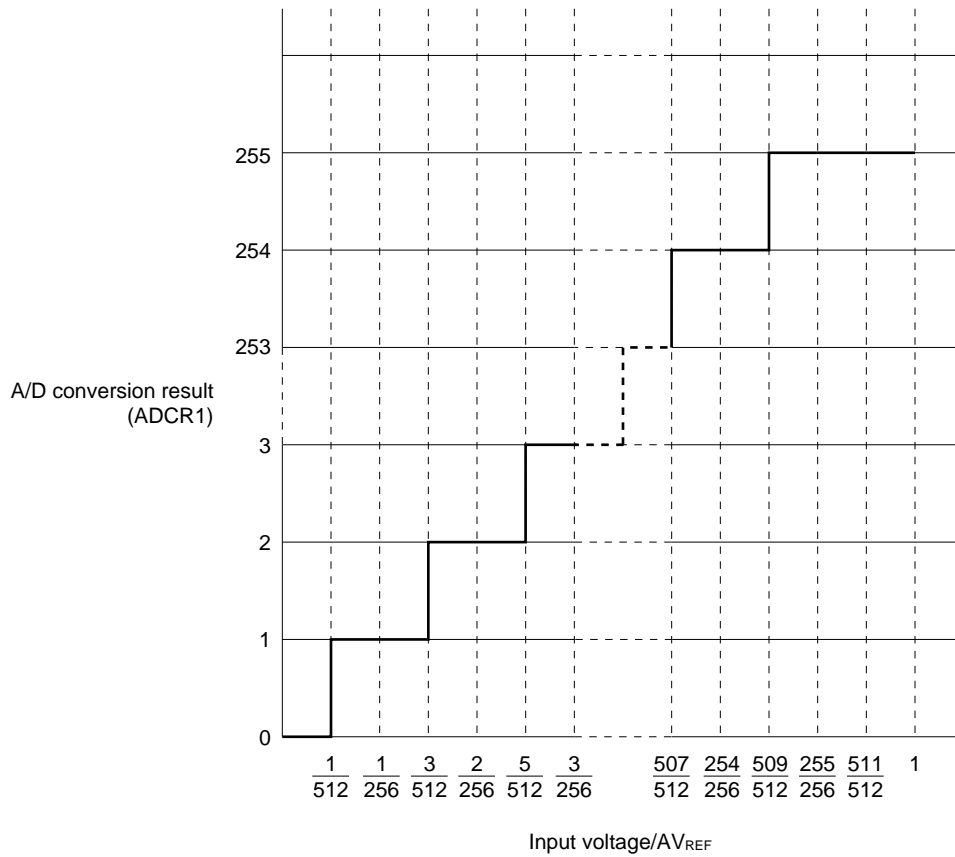

13.4.3 A/D converter operation mode

The operation mode of the A/D converter is the select mode. One analog input channel is selected from among ANI0 to ANI4 with the analog input channel specification register (ADS1) and A/D conversion is performed.

The following two types of functions can be selected by setting the PFEN flag of the PFM register.

- (1) Normal 8-bit A/D converter (PFEN = 0)
- (2) Power-fail detection function (PFEN = 1)

(1) A/D conversion (when PFEN = 0)

When bit 7 (ADCS1) of the A/D converter mode register (ADM1) is set to 1 and bit 7 of the power-fail compare mode register (PFM) is set to 0, A/D conversion of the voltage applied to the analog input pin specified with the analog input channel specification register (ADS1) starts.

Upon the end of the A/D conversion, the conversion result is stored in the A/D conversion result register (ADCR1), and the interrupt request signal (INTAD) is generated. After one A/D conversion operation is started and ended, the next conversion operation is immediately started. A/D conversion operations are repeated until new data is written to ADS1.

If ADS1 is rewritten during A/D conversion operation, the A/D conversion operation under execution is stopped, and A/D conversion of a newly selected analog input channel is started.

If data with ADCS1 set to 0 is written to ADM1 during A/D conversion operation, the A/D conversion operation stops immediately.

(2) Power-fail detection function (when PFEN = 1)

When bit 7 (ADCS1) of the A/D converter mode register (ADM1) and bit 7 (PFEN) of the power-fail compare mode register (PFM) are set to 1, A/D conversion of the voltage applied to the analog input pin specified with the analog input channel specification register (ADS1) starts.

Upon the end of the A/D conversion, the conversion result is stored in the A/D conversion result register (ADCR1), compared with the value of the power-fail compare threshold value register (PFT), and INTAD is generated under the condition specified by the PFCM flag of the PFM register.

Caution When executing power-fail comparison, the interrupt request signal (INTAD) is not generated on completion of the first conversion after ADCS1 has been set to 1. INTAD is valid from completion of the second conversion.

Figure 13-8. A/D Conversion

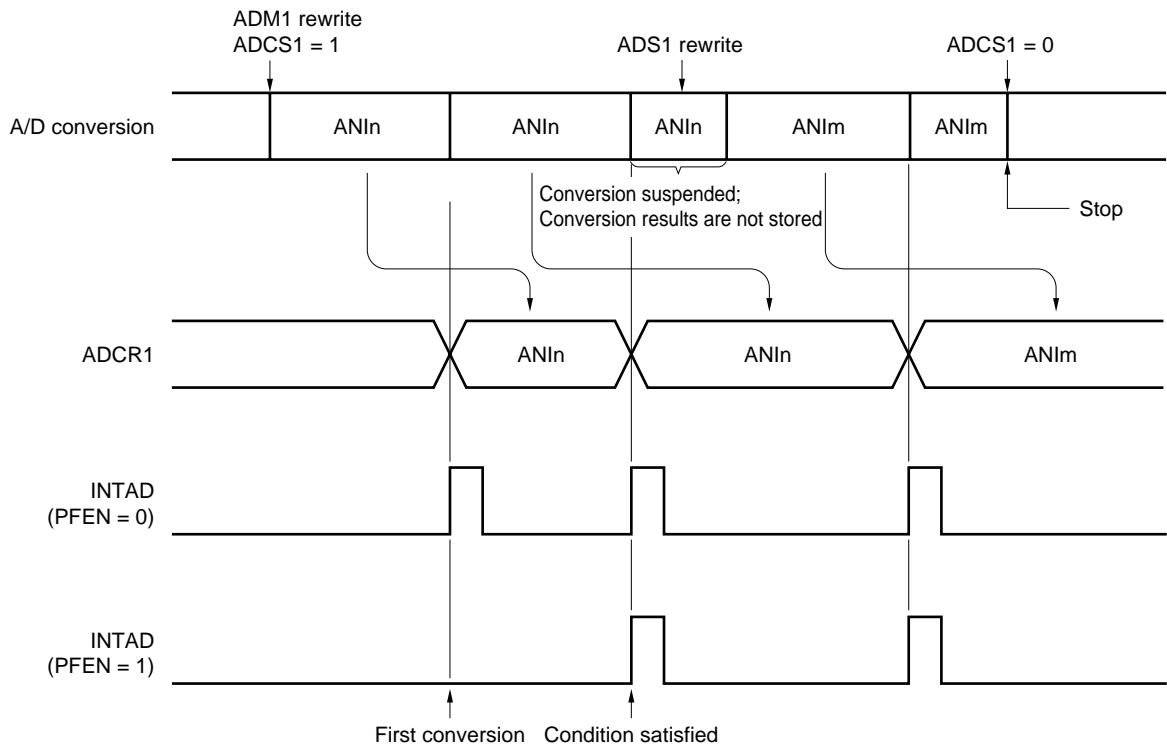

- Remarks**
1. $n = 0, 1, \dots, 4$
 2. $m = 0, 1, \dots, 4$

13.5 A/D Converter Cautions

(1) Current consumption in standby mode

A/D converter stops operating in the standby mode. At this time, current consumption can be reduced by setting bit 7 (ADCS1) of the A/D converter mode register (ADM1) to 0 to stop conversion.

Figure 13-9 shows how to reduce the current consumption in the standby mode.

Figure 13-9. Example of Method of Reducing Current Consumption in Standby Mode

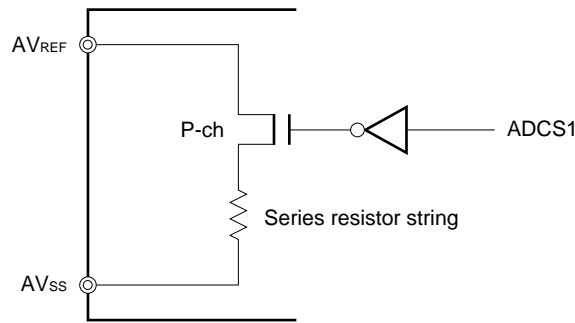

(2) Input range of ANI0 to ANI4

The input voltages of ANI0 to ANI4 should be within the specification range. In particular, if a voltage higher than AV_{REF} or lower than AV_{SS} is input (even if within the absolute maximum rating range), the conversion value of that channel will be undefined and the conversion values of other channels may also be affected.

(3) Contending operations

<1> Contention between A/D conversion result register (ADCR1) write and ADCR1 read by instruction upon the end of conversion

ADCR1 read is given priority. After the read operation, the new conversion result is written to ADCR1.

<2> Contention between ADCR1 write and A/D converter mode register (ADM1) write or analog input channel specification register (ADS1) write upon the end of conversion

ADM1 or ADS1 write is given priority. ADCR1 write is not performed, nor is the conversion end interrupt request signal (INTAD) generated.

(4) Noise countermeasures

To maintain 8-bit resolution, attention must be paid to noise input to pin AV_{REF} and pins $ANI0$ to $ANI4$. Because the effect increases in proportion to the output impedance of the analog input source, it is recommended that a capacitor be connected externally as shown in Figure 13-10 to reduce noise.

Figure 13-10. Analog Input Pin Connection

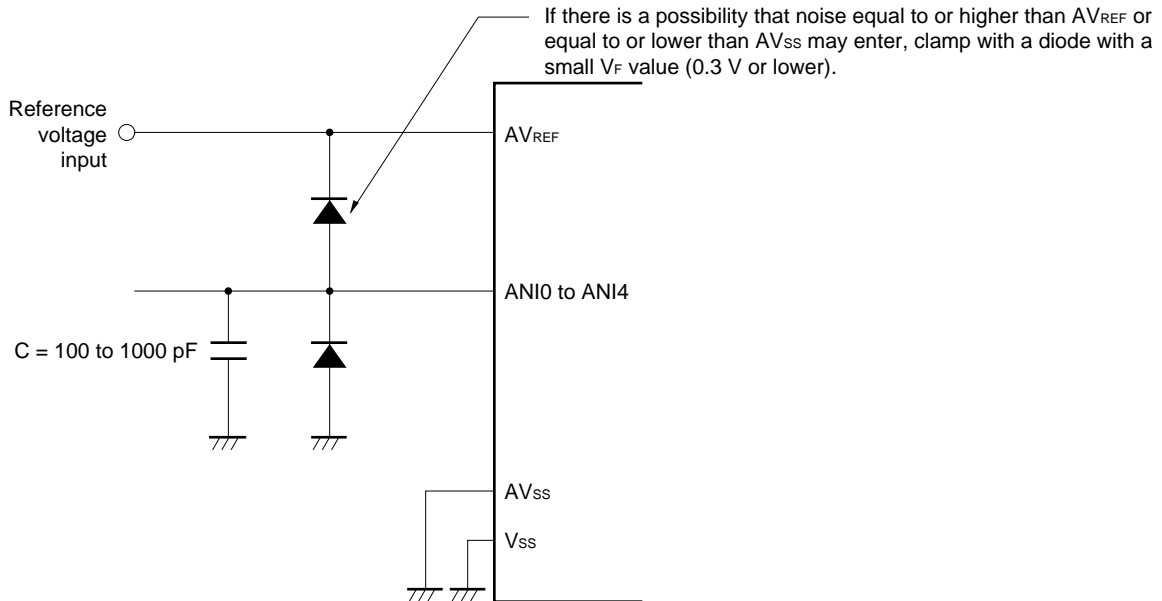
**(5) $ANI0$ to $ANI4$**

The analog input pins ($ANI0$ to $ANI4$) also function as input port pins ($P10$ to $P14$).

When A/D conversion is performed with any of pins $ANI0$ to $ANI4$ selected, do not execute a port input instruction while conversion is in progress, as this may reduce the conversion resolution.

Also, if digital pulses are applied to a pin adjacent to the pin in the process of A/D conversion, the expected A/D conversion value may not be obtainable due to coupling noise. Therefore, avoid applying pulses to pins adjacent to the pin undergoing A/D conversion.

(6) AV_{REF} pin input impedance

A series resistor string of approximately 21 k Ω is connected between the AV_{REF} pin and the AV_{SS} pin.

Therefore, if the output impedance of the reference voltage is high, this will result in parallel connection to the series resistor string between the AV_{REF} pin and the AV_{SS} pin, and there will be a large reference voltage error.

(7) Interrupt request flag (ADIF)

The interrupt request flag (ADIF) is not cleared even if the analog input channel specification register (ADS1) is changed.

Caution is therefore required since, if a change of analog input pin is performed during A/D conversion, the A/D conversion result and conversion end interrupt request flag for the pre-change analog input may be set just before the ADS1 rewrite, and when ADIF is read immediately after the ADS1 rewrite, ADIF may be set despite the fact that the A/D conversion for the post-change analog input has not ended.

When the A/D conversion is stopped and then resumed, clear ADIF before the A/D conversion operation is resumed.

Figure 13-11. A/D Conversion End Interrupt Request Generation Timing

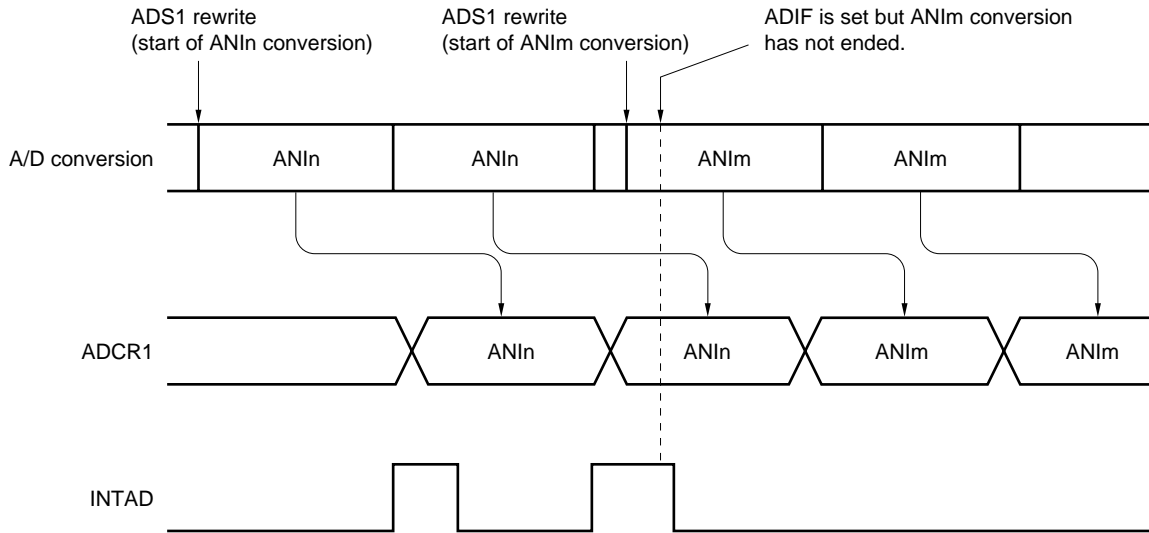

- Remarks**
1. $n = 0, 1, \dots, 4$
 2. $m = 0, 1, \dots, 4$

(8) Read of A/D conversion result register (ADCR1)

When write operation is executed to A/D converter mode register (ADM1) and analog input channel specification register (ADS1), the contents of ADCR1 are undefined. Read the conversion result before write operation is executed to ADM1, ADS1. If a timing other than the above is used, the correct conversion result may not be read.

★ 13.6 Cautions on Emulation

(1) D/A converter mode register (DAM1)

To perform debugging with an in-circuit emulator (IE-78K0-NS), the D/A converter mode register (DAM1) must be set. DAM1 is a register used to set a probe board (IE-780974-NS-EM1).

DAM1 is used when the power-fail detection function is used. Unless DAM1 is set, the power-fail detection function cannot be used. DAM1 is a write-only register.

Because the IE-780974-NS-EM1 uses an external analog comparator and a D/A converter to implement part of the power-fail detection function, the reference voltage must be controlled. Therefore, set bit 0 (DACE) of DAM1 to 1 when using the power-fail detection function.

Figure 13-12. D/A Converter Mode Register (DAM1) Format

Address: FF89H After Reset: 00H W

Symbol	7	6	5	4	3	2	1	0
DAM1	0	0	0	0	0	0	0	DACE

DACE	Reference Voltage Control
0	Disabled
1	Enabled (when power-fail detection function is used)

Cautions

- DAM1 is a special register that must be set when debugging is performed with an in-circuit emulator. Even if this register is used, the operation of the μ PD780973 Subseries is not affected. However, delete the instruction that manipulates this register from the program at the final stage of debugging.**

- Bits 7 to 1 must be set to 0.**

(2) A/D converter of IE-780974-NS-EM1

The A/D converter of the IE-780974-NS-EM1 may not satisfy the rating of the first A/D conversion value right after A/D conversion has been started.

The above applies only to the IE-780974-NS-EM1 and does not affect the operation of the μ PD780973 Subseries.

[MEMO]

CHAPTER 14 SERIAL INTERFACE UART

14.1 UART Functions

The serial interface UART has the following two modes.

(1) Operation stop mode

This mode is used when serial transfers are not performed to reduce power consumption. For details, see **14.4.1 Operation stop mode**.

(2) Asynchronous serial interface (UART) mode

This mode enables full-duplex operation wherein one byte of data is transmitted and received after the start bit. The on-chip dedicated UART baud rate generator enables communications using a wide range of selectable baud rates.

The UART baud rate generator can also be used to generate a MIDI-standard baud rate (31.25 kbps).

For details, see **14.4.2 Asynchronous serial interface (UART) mode**.

Figure 14-1 shows the UART block diagram.

Figure 14-1. UART Block Diagram

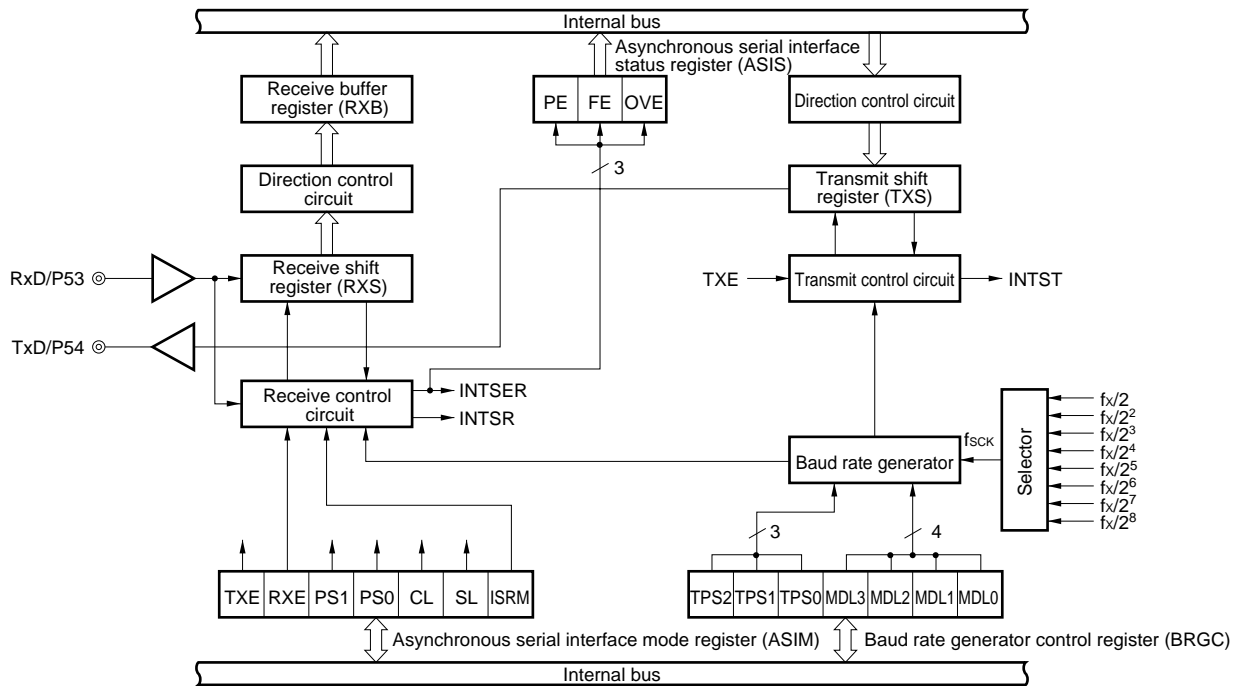

14.2 UART Configuration

The UART consists of the following hardware.

Table 14-1. UART Configuration

Item	Configuration
Registers	Transmit shift register (TXS) Receive shift register (RXS) Receive buffer register (RXB)
Control registers	Asynchronous serial interface mode register (ASIM) Asynchronous serial interface status register (ASIS) Baud rate generator control register (BRGC)

(1) Transmit shift register (TXS)

This is the register for setting transmit data. Data written to TXS is transmitted as serial data.

When the data length is set as 7 bits, bits 0 to 6 of the data written to TXS are transmitted as transmit data. Writing data to TXS starts the transmit operation.

TXS is written with an 8-bit memory manipulation instruction. It cannot be read.

When $\overline{\text{RESET}}$ is input, its value is FFH.

Caution Do not write to TXS during a transmit operation.

The same address is assigned to TXS and the receive buffer register (RXB). A read operation reads values from RXB.

(2) Receive shift register (RXS)

This register converts serial data input via the RxD pin to parallel data. When one byte of data is received at this register, the receive data is transferred to the receive buffer register (RXB).

RXS cannot be manipulated directly by a program.

(3) Receive buffer register (RXB)

This register is used to hold receive data. When one byte of data is received, one byte of new receive data is transferred from the receive shift register (RXS).

When the data length is set as 7 bits, receive data is transferred to bits 0 to 6 of RXB. In RXB, the MSB must be set to 0.

RXB is read with an 8-bit memory manipulation instruction. It cannot be written to.

When $\overline{\text{RESET}}$ is input, its value is FFH.

Caution The same address is assigned to RXB and the transmit shift register (TXS). During a write operation, values are written to TXS.

(4) Transmit control circuit

The transmit control circuit controls transmit operations, such as adding a start bit, parity bit, and stop bit to data that is written to the transmit shift register (TXS), based on the values set to the asynchronous serial interface mode register (ASIM).

(5) Receive control circuit

The receive control circuit controls receive operations based on the values set to the asynchronous serial interface mode register (ASIM). During a receive operation, it performs error checking, such as for parity errors, and sets various values to the asynchronous serial interface status register (ASIS) according to the type of error that is detected.

14.3 UART Control Registers

The UART uses the following three types of registers for control functions.

- Asynchronous serial interface mode register (ASIM)
- Asynchronous serial interface status register (ASIS)
- Baud rate generator control register (BRGC)

(1) Asynchronous serial interface mode register (ASIM)

This is an 8-bit register that controls UART's serial transfer operations.

ASIM is set with a 1-bit or 8-bit memory manipulation instruction.

$\overline{\text{RESET}}$ input clears the value to 00H.

Figure 14-2 shows the format of ASIM.

Caution In UART mode, set the port mode register (PM5X) as follows. Besides that, set all output latches to 0.

- **When receiving**
Set P53 (RxD) to the input mode (PM53 = 1)
- **When transmitting**
Set P54 (TxD) to the output mode (PM54 = 0)
- **When transceiving**
Set P53 to the input mode and P54 to the output mode

Figure 14-2. Asynchronous Serial Interface Mode Register (ASIM) Format

Address: FF85H After Reset: 00H R/W

Symbol	7	6	5	4	3	2	1	0
ASIM	TXE	RXE	PS1	PS0	CL	SL	ISRM	0

TXE	RXE	Operation Mode
0	0	Operation stop
0	1	UART mode (receive only)
1	0	UART mode (transmit only)
1	1	UART mode (transmit and receive)

PS1	PS0	Parity Bit Specification
0	0	No parity
0	1	Zero parity always added during transmission No parity detection during reception (parity errors do not occur)
1	0	Odd parity
1	1	Even parity

CL	Character Length Specification
0	7 bits
1	8 bits

SL	Stop Bit Length Specification for Transmit Data
0	1 bit
1	2 bits

ISRM	Receive Completion Interrupt Control when Error Occurs
0	Receive completion interrupt is issued when an error occurs
1	Receive completion interrupt is not issued when an error occurs

- Cautions**
1. Do not switch the operation mode until after the current serial transmit/receive operation has stopped.
 2. Bit 0 must be set to 0.

(2) Asynchronous serial interface status register (ASIS)

When a receive error occurs during UART mode, this register indicates the type of error.

ASIS is read with an 8-bit memory manipulation instruction.

When $\overline{\text{RESET}}$ is input, its value is 00H.

Figure 14-3. Asynchronous Serial Interface Status Register (ASIS) Format

Address: FF86H After Reset: 00H R

Symbol	7	6	5	4	3	2	1	0
ASIS	0	0	0	0	0	PE	FE	OVE

PE	Parity Error Flag
0	No parity error
1	Parity error (Transmit data parity does not match)

FE	Framing Error Flag
0	No framing error
1	Framing error Note 1 (Stop bit not detected)

OVE	Overrun Error Flag
0	No overrun error
1	Overrun error Note 2 (Next receive operation was completed before data was read from receive buffer register)

- Notes**
1. Even if a stop bit length of two bits has been set to bit 2 (SL) in the asynchronous serial interface mode register (ASIM), stop bit detection during a receive operation only applies to a stop bit length of 1 bit.
 2. Be sure to read the contents of the receive buffer register (RXB) when an overrun error has occurred.
Until the contents of RXB are read, further overrun errors will occur when receiving data.

(3) Baud rate generator control register (BRGC)

This register sets the serial clock for UART.

BRGC is set with an 8-bit memory manipulation instruction.

When $\overline{\text{RESET}}$ is input, its value is 00H.

Figure 14-4 shows the format of BRGC.

Figure 14-4. Baud Rate Generator Control Register (BRGC) Format

Address: FF87H After Reset: 00H R/W

Symbol	7	6	5	4	3	2	1	0
BRGC	0	TPS2	TPS1	TPS0	MDL3	MDL2	MDL1	MDL0

(fx = 8.38 MHz)

TPS2	TPS1	TPS0	Source Clock Selection for 5-bit Counter	n
0	0	0	$f_x/2$	1
0	0	1	$f_x/2^2$	2
0	1	0	$f_x/2^3$	3
0	1	1	$f_x/2^4$	4
1	0	0	$f_x/2^5$	5
1	0	1	$f_x/2^6$	6
1	1	0	$f_x/2^7$	7
1	1	1	$f_x/2^8$	8

MDL3	MDL2	MDL1	MDL0	Input Clock Selection for Baud Rate Generator	k
0	0	0	0	$f_{sck}/16$	0
0	0	0	1	$f_{sck}/17$	1
0	0	1	0	$f_{sck}/18$	2
0	0	1	1	$f_{sck}/19$	3
0	1	0	0	$f_{sck}/20$	4
0	1	0	1	$f_{sck}/21$	5
0	1	1	0	$f_{sck}/22$	6
0	1	1	1	$f_{sck}/23$	7
1	0	0	0	$f_{sck}/24$	8
1	0	0	1	$f_{sck}/25$	9
1	0	1	0	$f_{sck}/26$	10
1	0	1	1	$f_{sck}/27$	11
1	1	0	0	$f_{sck}/28$	12
1	1	0	1	$f_{sck}/29$	13
1	1	1	0	$f_{sck}/30$	14
1	1	1	1	Setting prohibited	—

Cautions 1. Writing to BRGC during a communication operation may cause abnormal output from the baud rate generator and disable further communication operations. Therefore, do not write to BRGC during a communication operation.

2. Bit 7 must be set to 0.

Remarks 1. f_{sck} : Source clock for 5-bit counter

2. n : Value set via TPS0 to TPS2 ($1 \leq n \leq 8$)

3. k : Value set via MDL0 to MDL3 ($0 \leq k \leq 14$)

14.4 UART Operations

This section explains the two modes of the UART.

14.4.1 Operation stop mode

This mode is used when serial transfers are not performed to reduce power consumption. In the operation stop mode, P53/RxD and P54/TxD pins can be used as ordinary ports.

(1) Register settings

Operation stop mode settings are made via the asynchronous serial interface mode register (ASIM). ASIM is set with a 1-bit or 8-bit memory manipulation instruction. When $\overline{\text{RESET}}$ is input, its value is 00H.

Address: FF85H After Reset: 00H R/W

Symbol	7	6	5	4	3	2	1	0
ASIM	TXE	RXE	PS1	PS0	CL	SL	ISRM	0

TXE	RXE	Operation Mode	RxD/P53 Pin Function	TxD/P54 Pin Function
0	0	Operation stop	Port function	Port function
0	1	UART mode (receive only)	Serial function	Port function
1	0	UART mode (transmit only)	Port function	Serial function
1	1	UART mode (transmit and receive)	Serial function	Serial function

- Cautions**
1. Do not switch the operation mode until after the current serial transmit/receive operation has stopped.
 2. Bit 0 must be set to 0.

14.4.2 Asynchronous serial interface (UART) mode

This mode enables full-duplex operation wherein one byte of data is transmitted or received after the start bit. The on-chip dedicated UART baud rate generator enables communications using a wide range of selectable baud rates.

The UART baud rate generator can also be used to generate a MIDI-standard baud rate (31.25 kbps).

(1) Register settings

UART mode settings are made via the asynchronous serial interface mode register (ASIM), asynchronous serial interface status register (ASIS), and the baud rate generator control register (BRGC).

(a) Asynchronous serial interface mode register (ASIM)

ASIM is set with a 1-bit or 8-bit memory manipulation instruction.

When $\overline{\text{RESET}}$ is input, its value is 00H.

Caution In UART mode, set the port mode register (PM5X) as follows. Besides that, set all output latches to 0.

- **When receiving**
Set P53 (RxD) to the input mode (PM53 = 1)
- **When transmitting**
Set P54 (TxD) to the output mode (PM54 = 0)
- **When transeiving**
Set P53 to the input mode and P54 to the output mode

Address: FF85H After Reset: 00H R/W

Symbol	7	6	5	4	3	2	1	0
ASIM	TXE	RXE	PS1	PS0	CL	SL	ISRM	0

TXE	RXE	Operation Mode	RxD/P53 Pin Function	TxD/P54 Pin Function
0	0	Operation stop	Port function	Port function
0	1	UART mode (receive only)	Serial function	Port function
1	0	UART mode (transmit only)	Port function	Serial function
1	1	UART mode (transmit and receive)	Serial function	Serial function

PS1	PS0	Parity Bit Specification
0	0	No parity
0	1	Zero parity always added during transmission No parity detection during reception (parity errors do not occur)
1	0	Odd parity
1	1	Even parity

CL	Character Length Specification
0	7 bits
1	8 bits

SL	Stop Bit Length Specification for Transmit Data
0	1 bit
1	2 bits

ISRM	Receive Completion Interrupt Control when Error Occurs
0	Receive completion interrupt is issued when an error occurs
1	Receive completion interrupt is not issued when an error occurs

Cautions 1. Do not switch the operation mode until after the current serial transmit/receive operation has stopped.

2. Bit 0 must be set to 0.

(b) Asynchronous serial interface status register (ASIS)

ASIS is read with an 8-bit memory manipulation instruction.

When $\overline{\text{RESET}}$ is input, its value is 00H.

Address: FF86H After Reset: 00H R

Symbol	7	6	5	4	3	2	1	0
ASIS	0	0	0	0	0	PE	FE	OVE

PE	Parity Error Flag
0	No parity error
1	Parity error (Transmit data parity does not match)

FE	Framing Error Flag
0	No framing error
1	Framing error Note 1 (Stop bit not detected)

OVE	Overrun Error Flag
0	No overrun error
1	Overrun error Note 2 (Next receive operation was completed before data was read from receive buffer register)

- Notes**
1. Even if a stop bit length of two bits has been set to bit 2 (SL) in the asynchronous serial interface mode register (ASIM), stop bit detection during a receive operation only applies to a stop bit length of 1 bit.
 2. Be sure to read the contents of the receive buffer register (RXB) when an overrun error has occurred.
Until the contents of RXB are read, further overrun errors will occur when receiving data.

(c) Baud rate generator control register (BRGC)

BRGC is set with an 8-bit memory manipulation instruction.

When $\overline{\text{RESET}}$ is input, its value is 00H.

Address: FF87H After Reset: 00H R/W

Symbol	7	6	5	4	3	2	1	0
BRGC	0	TPS2	TPS1	TPS0	MDL3	MDL2	MDL1	MDL0

(fx = 8.38 MHz)

TPS2	TPS1	TPS0	Source Clock Selection for 5-bit Counter	n
0	0	0	$fx/2$	1
0	0	1	$fx/2^2$	2
0	1	0	$fx/2^3$	3
0	1	1	$fx/2^4$	4
1	0	0	$fx/2^5$	5
1	0	1	$fx/2^6$	6
1	1	0	$fx/2^7$	7
1	1	1	$fx/2^8$	8

MDL3	MDL2	MDL1	MDL0	Input Clock Selection for Baud Rate Generator	k
0	0	0	0	$fsck/16$	0
0	0	0	1	$fsck/17$	1
0	0	1	0	$fsck/18$	2
0	0	1	1	$fsck/19$	3
0	1	0	0	$fsck/20$	4
0	1	0	1	$fsck/21$	5
0	1	1	0	$fsck/22$	6
0	1	1	1	$fsck/23$	7
1	0	0	0	$fsck/24$	8
1	0	0	1	$fsck/25$	9
1	0	1	0	$fsck/26$	10
1	0	1	1	$fsck/27$	11
1	1	0	0	$fsck/28$	12
1	1	0	1	$fsck/29$	13
1	1	1	0	$fsck/30$	14
1	1	1	1	Setting prohibited	—

- Cautions**
1. Writing to BRGC during a communication operation may cause abnormal output from the baud rate generator and disable further communication operations. Therefore, do not write to BRGC during a communication operation.
 2. Bit 7 must be set to 0.

- Remarks**
1. $fsck$: Source clock for 5-bit counter
 2. n : Value set via TPS0 to TPS2 ($1 \leq n \leq 8$)
 3. k : Value set via MDL0 to MDL3 ($0 \leq k \leq 14$)

The transmit/receive clock that is used to generate the baud rate is obtained by dividing the main system clock.

- **Use of main system clock to generate a transmit/receive clock for baud rate**

The main system clock is divided to generate the transmit/receive clock. The baud rate generated by the main system clock is determined according to the following formula.

$$[\text{Baud rate}] = \frac{f_x}{2^{n+1}(k + 16)} \text{ [Hz]}$$

f_x : Main system clock oscillation frequency

n : Value set via TPS0 to TPS2 ($1 \leq n \leq 8$)

For details, see Table 14-2.

k : Value set via MDL0 to MDL3 ($0 \leq k \leq 14$)

Table 14-2 shows the relation between the 5-bit counter's source clock assigned to bits 4 to 6 (TPS0 to TPS2) of BRGC and the "n" value in the above formula.

Table 14-2. Relation between 5-bit Counter's Source Clock and "n" Value

TPS2	TPS1	TPS0	5-bit Counter's Source Clock Selection	n
0	0	0	$f_x/2$	1
0	0	1	$f_x/2^2$	2
0	1	0	$f_x/2^3$	3
0	1	1	$f_x/2^4$	4
1	0	0	$f_x/2^5$	5
1	0	1	$f_x/2^6$	6
1	1	0	$f_x/2^7$	7
1	1	1	$f_x/2^8$	8

Remark f_x : Main system clock oscillation frequency ($f_x = 8.38 \text{ MHz}$)

• **Error tolerance range for baud rates**

The tolerance range for baud rates depends on the number of bits per frame and the counter's division rate $[1/(16 + k)]$.

Table 14-3 describes the relation between the main system clock and the baud rate and Figure 14-5 shows an example of a baud rate error tolerance range.

Table 14-3. Relation between Main System Clock and Baud Rate

Baud rate (bps)	$f_x = 8.386 \text{ MHz}$	
	BRGC Set Value	Error (%)
600	7BH	1.10
1200	6BH	1.10
2400	5BH	1.10
4800	4BH	1.10
9600	3BH	1.10
19200	2BH	-1.3
31250	21H	1.10
38400	1BH	1.10
76800	0BH	1.10
115200	01H	1.03

Remark f_x : Main system clock oscillation frequency

Figure 14-5. Error Tolerance (when $k = 0$) including Sampling Errors

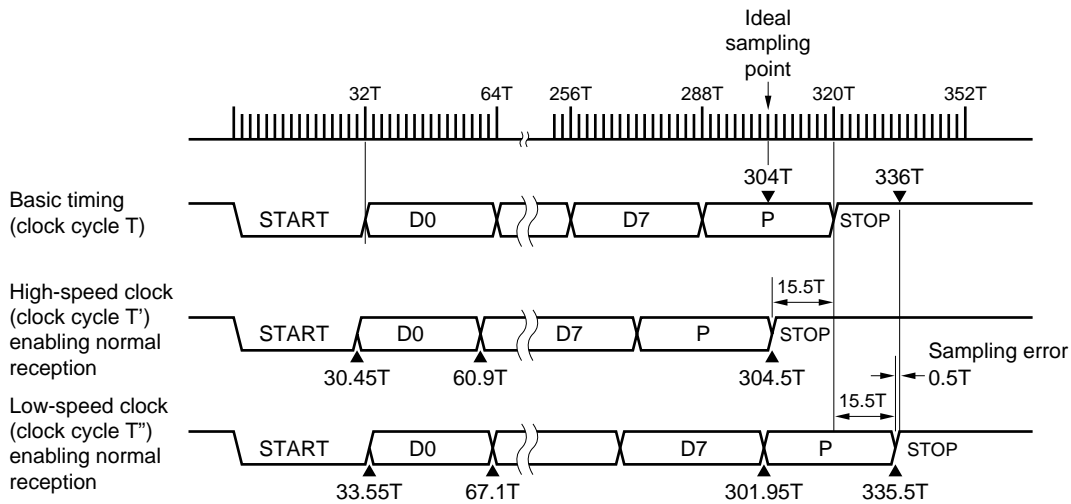

Remark T : 5-bit counter's source clock cycle

$$\text{Baud rate error tolerance (when } k = 0) = \frac{\pm 15.5}{320} \times 100 = 4.8438 \%$$

(2) Communication operations**(a) Data format**

As shown in Figure 14-6, the format of the transmit/receive data consists of a start bit, character bits, a parity bit, and one or more stop bits.

The asynchronous serial interface mode register (ASIM) is used to set the character bit length, parity selection, and stop bit length within each data frame.

Figure 14-6. Format of Transmit/Receive Data in Asynchronous Serial Interface

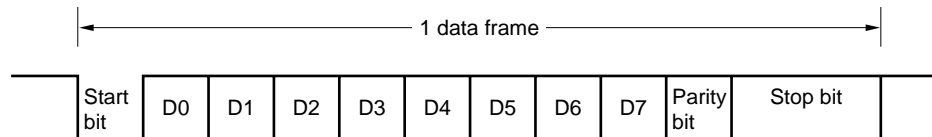

- Start bit 1 bit
- Character bits ... 7 bits or 8 bits
- Parity bit Even parity, odd parity, zero parity, or no parity
- Stop bit(s) 1 bit or 2 bits

When “7 bits” is selected as the number of character bits, only the low-order 7 bits (bits 0 to 6) are valid, so that during a transmission the highest bit (bit 7) is ignored and during reception the highest bit (bit 7) must be set to “0”.

The asynchronous serial interface mode register (ASIM) and the baud rate generator control register (BRGC) are used to set the serial transfer rate.

If a receive error occurs, information about the receive error can be recognized by reading the asynchronous serial interface status register (ASIS).

(b) Parity types and operations

The parity bit is used to detect bit errors in transfer data. Usually, the same type of parity bit is used by the transmitting and receiving sides. When odd parity or even parity is set, errors in the parity bit (the odd-number bit) can be detected. When zero parity or no parity is set, errors are not detected.

(i) Even parity

- During transmission

The number of bits in transmit data that includes a parity bit is controlled so that there are an even number of “1” bits. The value of the parity bit is as follows.

If the transmit data contains an odd number of “1” bits : the parity bit value is “1”

If the transmit data contains an even number of “1” bits: the parity bit value is “0”

- During reception

The number of “1” bits is counted among the receive data that include a parity bit, and a parity error occurs when the result is an odd number.

(ii) Odd parity

- During transmission

The number of bits in transmit data that includes a parity bit is controlled so that there is an odd number of “1” bits. The value of the parity bit is as follows.

If the transmit data contains an odd number of “1” bits : the parity bit value is “0”

If the transmit data contains an even number of “1” bits: the parity bit value is “1”

- During reception

The number of “1” bits is counted among the receive data that include a parity bit, and a parity error occurs when the result is an even number.

(iii) Zero parity

During transmission, the parity bit is set to “0” regardless of the transmit data.

During reception, the parity bit is not checked. Therefore, no parity errors will occur regardless of whether the parity bit is a “0” or a “1”.

(iv) No parity

No parity bit is added to the transmit data.

During reception, receive data is regarded as having no parity bit. Since there is no parity bit, no parity errors will occur.

(c) Transmission

The transmit operation is started when transmit data is written to the transmit shift register (TXS). A start bit, parity bit, and stop bit(s) are automatically added to the data.

Starting the transmit operation shifts out the data in TXS, thereby emptying TXS, after which a transmit completion interrupt (INTST) is issued.

The timing of the transmit completion interrupt is shown in Figure 14-7.

Figure 14-7. Timing of Asynchronous Serial Interface Transmit Completion Interrupt

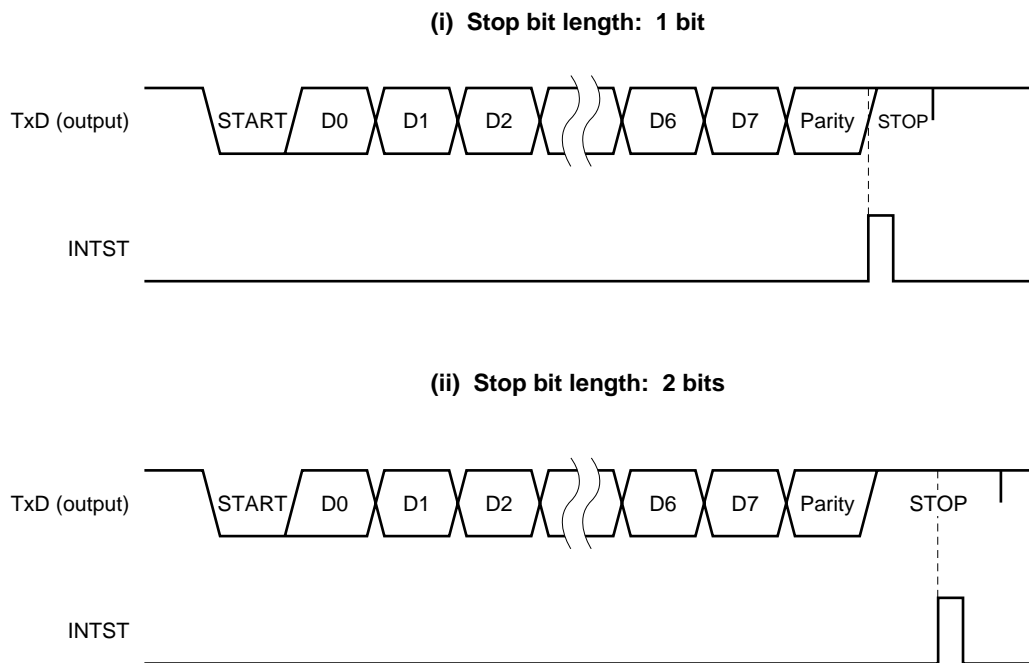

Caution Do not rewrite the asynchronous serial interface mode register (ASIM) during a transmit operation. Rewriting to the ASIM register during a transmit operation may disable further transmit operations (in such case, enter a **RESET** to restore normal operation). Whether or not a transmit operation is in progress can be determined by software using the transmit completion interrupt (INTST) or the interrupt request flag (STIF) that is set by INTST.

(d) Reception

The receive operation is enabled when “1” is set to bit 6 (RXE) of the asynchronous serial interface mode register (ASIM), and input via the RxD pin is sampled.

The serial clock specified by ASIM is used when sampling the RxD pin.

When the RxD pin goes low, the 5-bit counter begins counting and the start timing signal for data sampling is output when half of the specified baud rate time has elapsed. If sampling the RxD pin input with this start timing signal yields a low-level result, a start bit is recognized, after which the 5-bit counter is initialized and starts counting and data sampling begins. After the start bit is recognized, the character data, parity bit, and one-bit stop bit are detected, at which point reception of one data frame is completed.

Once reception of one data frame is completed, the receive data in the shift register is transferred to the receive buffer register (RXB) and a receive completion interrupt (INTSR) occurs.

Even if an error has occurred, the receive data in which the error occurred is still transferred to RXB. INTSR occurs if bit 1 (ISRM) of ASIM is cleared to 0 on occurrence of an error. If the ISRM bit is set to 1, INTSR does not occur (see Figure 14-9).

If the RXE bit is reset (to “0”) during a receive operation, the receive operation is stopped immediately. At this time, the contents of RXB and ASIS do not change, nor does INTSR or INTSER occur.

Figure 14-8 shows the timing of the asynchronous serial interface receive completion interrupt.

Figure 14-8. Timing of Asynchronous Serial Interface Receive Completion Interrupt

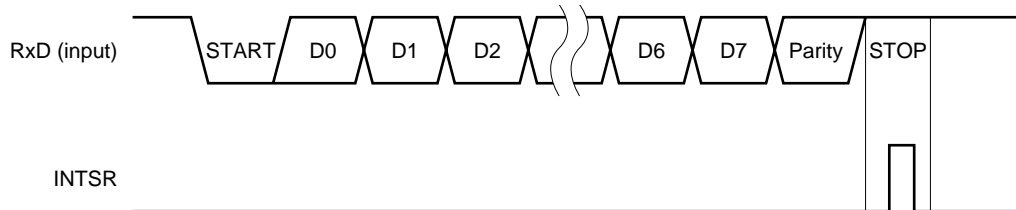

Caution Be sure to read the contents of the receive buffer register (RXB) even when a receive error has occurred. Overrun errors will occur during the next data receive operations and the receive error status will remain until the contents of RXB are read.

(e) Receive errors

Three types of errors can occur during a receive operation: parity error, framing error, or overrun error. If, as the result of data reception, an error flag is set to the asynchronous serial interface status register (ASIS), a receive error interrupt (INTSER) will occur. Receive error interrupts are generated before receive interrupts (INTSR). Table 14-4 lists the causes behind receive errors.

As part of receive error interrupt (INTSER) servicing, the contents of ASIS can be read to determine which type of error occurred during the receive operation (see Table 14-4 and Figure 14-9).

The contents of ASIS are reset (to "0") when the receive buffer register (RXB) is read or when the next data is received (if the next data contains an error, another error flag will be set).

Table 14-4. Causes of Receive Errors

Receive Error	Cause	ASIS Value
Parity error	Parity specified during transmission does not match parity of receive data	04H
Framing error	Stop bit was not detected	02H
Overrun error	Reception of the next data was completed before data was read from the receive buffer register	01H

Figure 14-9. Receive Error Timing

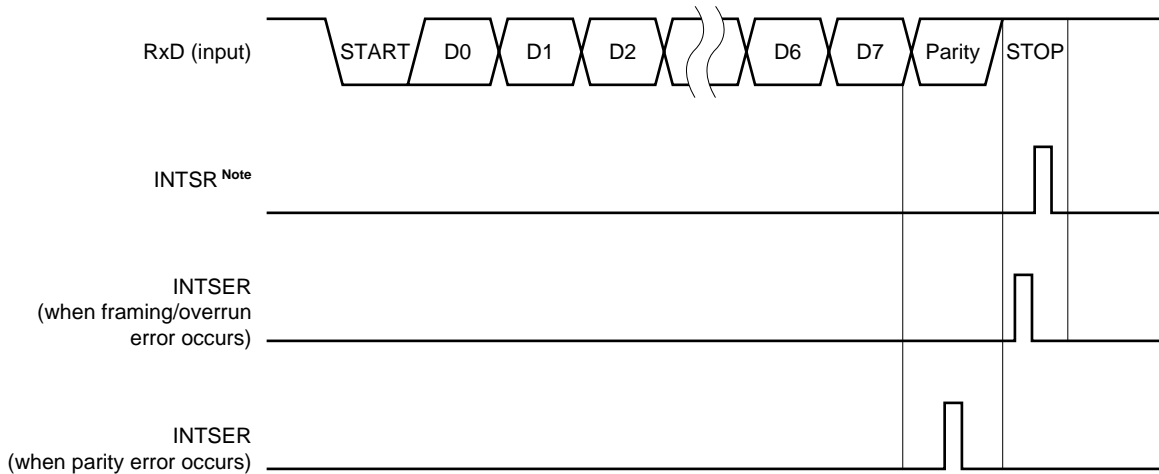

Note If a reception error occurs when bit 1 (ISRM) of the asynchronous serial interface mode register (ASIM) is set to 1, INTSR does not occur.

- Cautions**
- 1. The contents of asynchronous serial interface status register (ASIS) are reset (to "0") when the receive buffer register (RXB) is read or when the next data is received. To obtain information about the error, be sure to read the contents of ASIS before reading RXB.**
 - 2. Be sure to read the contents of the receive buffer register (RXB) even when a receive error has occurred. Overrun errors will occur during the next data receive operations and the receive error status will remain until the contents of RXB are read.**

[MEMO]

CHAPTER 15 SERIAL INTERFACE SIO3

15.1 SIO3 Functions

The serial interface SIO3 has the following two modes.

(1) Operation stop mode

This mode is used when serial transfers are not performed. For details, see **15.4.1 Operation stop mode**.

(2) 3-wire serial I/O mode (fixed as MSB first)

This is an 8-bit data transfer mode using three lines: a serial clock line ($\overline{\text{SCK}}$), serial output line (SO), and serial input line (SI).

Since simultaneous transmit and receive operations are enabled in 3-wire serial I/O mode, the processing time for data transfers is reduced.

The first bit in the 8-bit data in serial transfers is fixed as the MSB.

3-wire serial I/O mode is useful for connection to a peripheral I/O device that includes a clock-synchronous serial interface, a display controller, etc. For details, see **15.4.2 Three-wire serial I/O mode**.

Figure 15-1 shows the SIO3 block diagram.

Figure 15-1. SIO3 Block Diagram

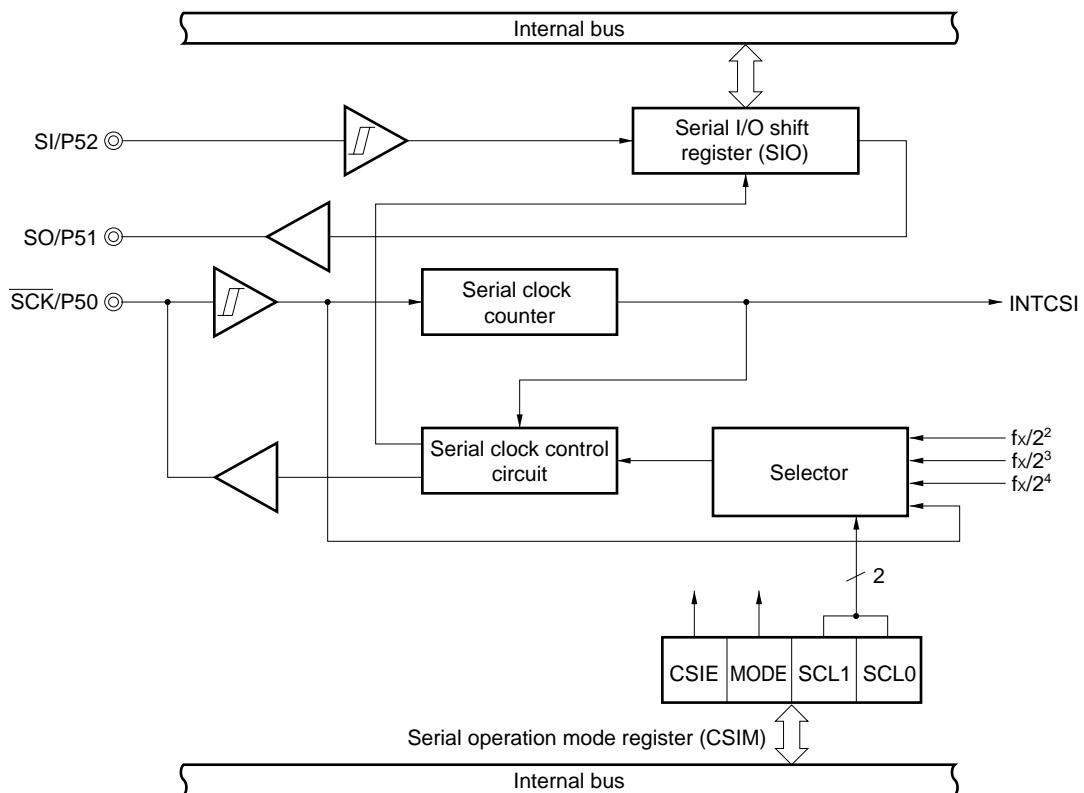

15.2 SIO3 Configuration

The SIO3 consists of the following hardware.

Table 15-1. SIO3 Configuration

Item	Configuration
Register	Serial I/O shift register (SIO)
Control register	Serial operation mode register (CSIM)

(1) Serial I/O shift register (SIO)

This is an 8-bit register that performs parallel-serial conversion and serial transmit/receive (shift operations) synchronized with the serial clock.

SIO is set with an 8-bit memory manipulation instruction.

When "1" is set to bit 7 (CSIE) of the serial operation mode register (CSIM), a serial operation can be started by writing data to or reading data from SIO.

When transmitting, data written to SIO is output via the serial output (SO).

When receiving, data is read from the serial input (SI) and written to SIO.

The $\overline{\text{RESET}}$ signal resets the register value to 00H.

Caution Do not access SIO during a transfer operation unless the access is triggered by a transfer start (Read is disabled when MODE = 0 and write is disabled when MODE = 1).

15.3 SIO3 Control Register

The SIO3 uses the following type of register for control functions.

- Serial operation mode register (CSIM)

(1) Serial operation mode register (CSIM)

This register is used to enable or disable SIO3's serial clock, operation modes, and specific operations.

CSIM is set with a 1-bit or 8-bit memory manipulation instruction.

The $\overline{\text{RESET}}$ input resets the value to 00H.

Caution In the 3-wire serial I/O mode, set the port mode register (PM5X) as follows. Besides that, set all output latches to 0.

- When serial clock output (Master transmit or Master receive)
Set P50 ($\overline{\text{SCK}}$) to the output mode (PM50 = 0)
- When serial clock input (Slave transmit or Slave receive)
Set P50 to the input mode (PM50 = 1)
- When transmit/transceive mode
Set P51 (SO) to the output mode (PM51 = 0)
- When receive mode
Set P52 (SI) to the input mode (PM52 = 1)

Figure 15-2. Serial Operation Mode Register (CSIM) Format

Address: FF84H After Reset: 00H R/W

Symbol	7	6	5	4	3	2	1	0
CSIM	CSIE	0	0	0	0	MODE	SCL1	SCL0

CSIE	SIO3 Operation Enable/Disable Specification	
	Shift Register Operation	
0	Operation disable	
1	Operation enable	

MODE	Transfer Operation Mode Flag	
	Operation Mode	
0	Transmit or transmit/receive mode	
1	Receive-only mode	

SCL1	SCL0	Clock Selection ($f_x = 8.38 \text{ MHz}$)
0	0	External clock input
0	1	$f_x/2^2$
1	0	$f_x/2^3$
1	1	$f_x/2^4$

Caution Bits 3 to 6 must be set to 0.

15.4 SIO3 Operations

This section explains the two modes of the SIO3.

15.4.1 Operation stop mode

This mode is used when serial transfers are not performed to reduce power consumption.

In the operation stop mode, the P50/ $\overline{\text{SCK}}$, P51/SO, and P52/SI pins can be used as normal I/O ports as well.

(1) Register settings

Operation stop mode are set via serial operation mode register (CSIM).

CSIM is set with a 1-bit or 8-bit memory manipulation instruction.

The $\overline{\text{RESET}}$ input resets the value to 00H.

Figure 15-3. Serial Operation Mode Register (CSIM) Format

Address: FF84H After Reset: 00H R/W

Symbol	7	6	5	4	3	2	1	0
CSIM	CSIE	0	0	0	0	MODE	SCL1	SCL0

CSIE	SIO3 Operation Enable/Disable Specification
	Shift Register Operation
0	Operation disable
1	Operation enable

Caution Bits 3 to 6 must be set to 0.

15.4.2 Three-wire serial I/O mode

The three-wire serial I/O mode is useful when connecting a peripheral I/O device that includes a clock-synchronous serial interface, a display controller, etc.

This mode executes data transfers via three lines: a serial clock line ($\overline{\text{SCK}}$), serial output line (SO), and serial input line (SI).

(1) Register settings

3-wire serial I/O mode is set via serial operation mode register (CSIM).

CSIM is set with a 1-bit or 8-bit memory manipulation instruction.

The $\overline{\text{RESET}}$ input resets the value to 00H.

Caution In the 3-wire serial I/O mode, set the port mode register (PM5X) as follows. Besides that, set all output latches to 0.

- When serial clock output (Master transmit or Master receive)
Set P50 (SCK) to the output mode (PM50 = 0)
- When serial clock input (Slave transmit or Slave receive)
Set P50 to the input mode (PM50 = 1)
- When transmit/transceive mode
Set P51 (SO) to the output mode (PM51 = 0)
- When receive mode
Set P52 (SI) to the input mode (PM52 = 1)

Figure 15-4. Serial Operation Mode Register (CSIM) Format

Address: FF84H After Reset: 00H R/W

Symbol	7	6	5	4	3	2	1	0
CSIM	CSIE	0	0	0	0	MODE	SCL1	SCL0

CSIE	SIO3 Operation Enable/Disable Specification	
	Shift Register Operation	
0	Operation disable	
1	Operation enable	

MODE	Transfer Operation Mode Flag	
	Operation Mode	
0	Transmit or transmit/receive mode	
1	Receive-only mode	

SCL1	SCL0	Clock Selection (fx = 8.38 MHz)
0	0	External clock input
0	1	$f_x/2^2$
1	0	$f_x/2^3$
1	1	$f_x/2^4$

Caution Bits 3 to 6 must be set to 0.

(2) Communication operations

In the three-wire serial I/O mode, data is transmitted and received in 8-bit units. Each bit of data is transmitted or received in synchronized with the serial clock.

The serial I/O shift register (SIO) is shifted in synchronized with the falling edge of the serial clock. Transmission data is held in the SO latch and is output from the SO pin. Data that is received via the SI pin in synchronized with the rising edge of the serial clock is latched to SIO.

Completion of an 8-bit transfer automatically stops operation of SIO3 and sets a serial transfer completion flag.

Figure 15-5. Three-Wire Serial I/O Mode Timing

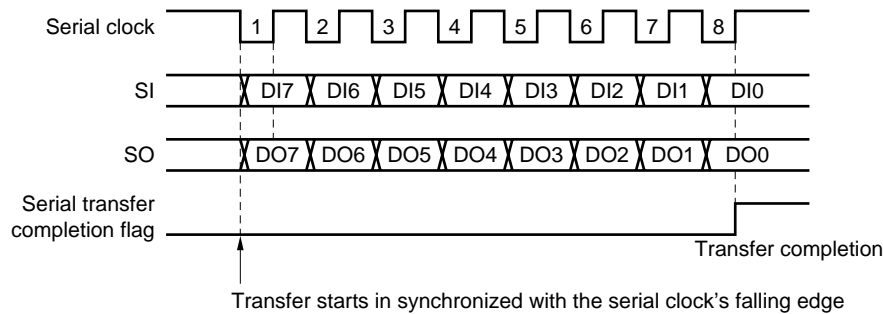
**(3) Transfer start**

A serial transfer starts when the following two conditions have been satisfied and transfer data has been set to serial I/O shift register (SIO).

- SIO3 operation control bit (CSIE) = 1
- After an 8-bit serial transfer, the internal serial clock is either stopped or is set to high level.
- Transmit or transmit/receive mode
 - When CSIE = 1 and MODE = 0, transfer starts when writing to SIO.
- Receive-only mode
 - When CSIE = 1 and MODE = 1, transfer starts when reading from SIO.

Caution After data has been written to SIO, transfer will not start even if the CSIE bit value is set to “1”.

Completion of an 8-bit transfer automatically stops the serial transfer operation and sets a serial transfer completion flag.

CHAPTER 16 LCD CONTROLLER/DRIVER

16.1 LCD Controller/Driver Functions

The functions of the LCD controller/driver incorporated in the μ PD780973 Subseries are shown below.

- (1) Automatic output of segment signals and common signals is possible by automatic reading of the display data memory.
- (2) Display mode
 - 1/4 duty (1/3 bias)
- (3) Any of four frame frequencies can be selected in each display mode.
- (4) Maximum of 20 segment signal outputs (S0 to S19); 4 common signal outputs (COM0 to COM3).
Fifteen of the segment signal outputs can be switched to input/output ports in units of 2 (P81/S19 to P87/S13, P90/S12 to P97/S5).

The maximum number of displayable pixels is shown in Table 16-1.

Table 16-1. Maximum Number of Display Pixels

Bias Method	Time Division	Common Signals Used	Maximum Number of Display Pixels
1/3	4	COM0 to COM3	80 (20 segments \times 4 commons) Note

Note 10 digits on \square type LCD panel with 2 segments/digit.

16.2 LCD Controller/Driver Configuration

The LCD controller/driver consists of the following hardware.

Table 16-2. LCD Controller/Driver Configuration

Item	Configuration
Display outputs	Segment signals : 20 Dedicated segment signals: 5 Segment signal/input/output port alternate function: 14 Segment signal/input/output port/16-bit timer prescaler output alternate function: 1 Common signals : 4 (COM0 to COM3)
Control registers	LCD display mode register (LCDM) LCD display control register (LCDC)

Figure 16-1. LCD Controller/Driver Block Diagram

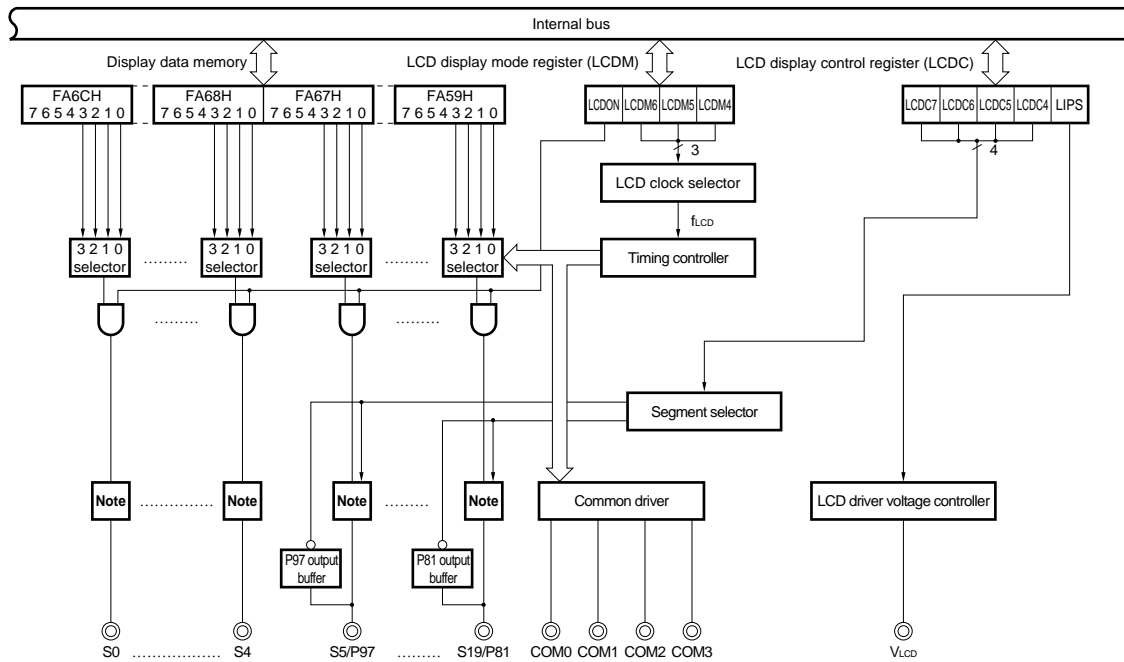

Note Segment driver

Figure 16-2. LCD Clock Select Circuit Block Diagram

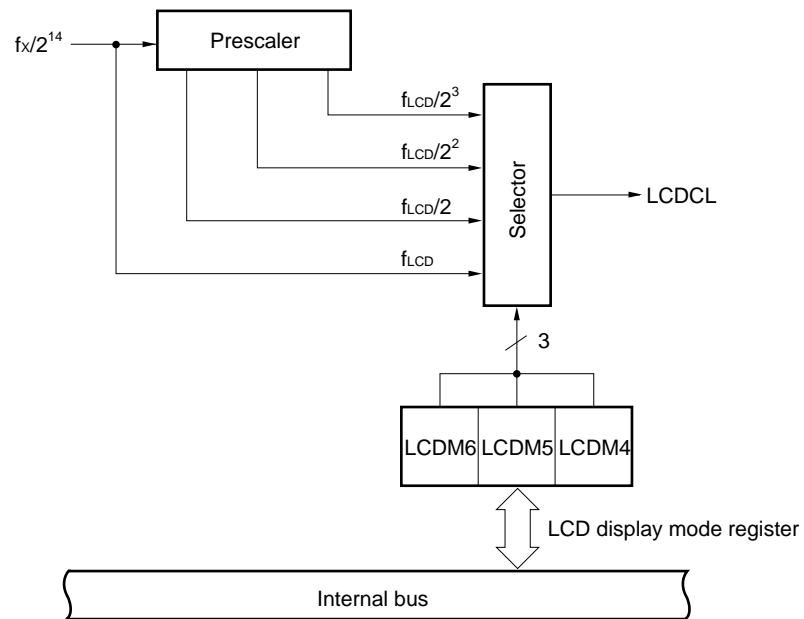

- Remarks**
1. LCDCL : LCD clock
 2. f_{LCD} : LCD clock frequency

16.3 LCD Controller/Driver Control Registers

The LCD controller/driver is controlled by the following two registers.

- LCD display mode register (LCDM)
- LCD display control register (LCDC)

(1) LCD display mode register (LCDM)

This register sets display operation enabling/disabling, the LCD clock, frame frequency.

LCDM is set with a 1-bit or 8-bit memory manipulation instruction.

RESET input clears LCDM to 00H.

Figure 16-3. LCD Display Mode Register (LCDM) Format

Address: FFB0H After Reset: 00H R/W

Symbol	7	6	5	4	3	2	1	0
LCDM	LCDON	LCDM6	LCDM5	LCDM4	0	0	0	0

LCDON	LCD Display Enable/Disable
0	Display off (all segment outputs are non-select signal outputs)
1	Display on

LCDM6	LCDM5	LCDM4	LCD Clock Selection ($f_x = 8.38 \text{ MHz}$)
0	0	0	$f_x/2^{17}$ (64 Hz)
0	0	1	$f_x/2^{16}$ (128 Hz)
0	1	0	$f_x/2^{15}$ (256 Hz)
0	1	1	$f_x/2^{14}$ (512 Hz)
Other than above			Setting prohibited

Remark f_x = Main system clock oscillation frequency

(2) LCD display control register (LCDC)

This register sets cutoff of the current flowing to split resistors for LCD drive voltage generation and switchover between segment output and input/output port functions.

LCDC is set with a 1-bit or 8-bit memory manipulation instruction.

RESET input clears LCDC to 00H.

Figure 16-4. LCD Display Control Register (LCDC) Format

Address: FFB2H After Reset: 00H R/W

Symbol	7	6	5	4	3	2	1	0
LCDC	LCDC7	LCDC6	LCDC5	LCDC4	0	0	0	LIPS

LCDC7	LCDC6	LCDC5	LCDC4	P81/S19 to P97/S5 Pin Functions	
				Port Pins	Segment Pins
0	0	0	0	P81 to P97	None
0	0	0	1	P81 to P95	S5 to S6
0	0	1	0	P81 to P93	S5 to S8
0	0	1	1	P81 to P91	S5 to S10
0	1	0	0	P81 to P87	S5 to S12
0	1	0	1	P81 to P85	S5 to S14
0	1	1	0	P81 to P83	S5 to S16
0	1	1	1	P81	S5 to S18
1	0	0	0	None	S5 to S19
Other than above				Setting prohibited	

LIPS	LCD Driving Power Supply Selection
0	Does not supply power to LCD.
1	Supplies power to LCD from V _{DD} pin.

- Cautions**
- 1. Pins which perform segment output cannot be used as output port pins even if 0 is set in the port mode register.**
 - 2. If a pin which performs segment output is read as a port, its value will be 0.**

16.4 LCD Controller/Driver Settings

LCD controller/driver settings should be performed as shown below.

- <1> Set the initial value in the display data memory (FA59H to FA6CH).
- <2> Set the pins to be used as segment outputs in the LCD display control register (LCDC).
- <3> Set the LCD clock in the LCD display mode register (LCDM).

Next, set data in the display data memory according to the display contents.

16.5 LCD Display Data Memory

The LCD display data memory is mapped onto addresses FA59H to FA6CH. The data stored in the LCD display data memory can be displayed on an LCD panel by the LCD controller/driver.

Figure 16-5 shows the relationship between the LCD display data memory contents and the segment outputs/common outputs.

Any area not used for display can be used as normal RAM.

Figure 16-5. Relationship between LCD Display Data Memory Contents and Segment/Common Outputs

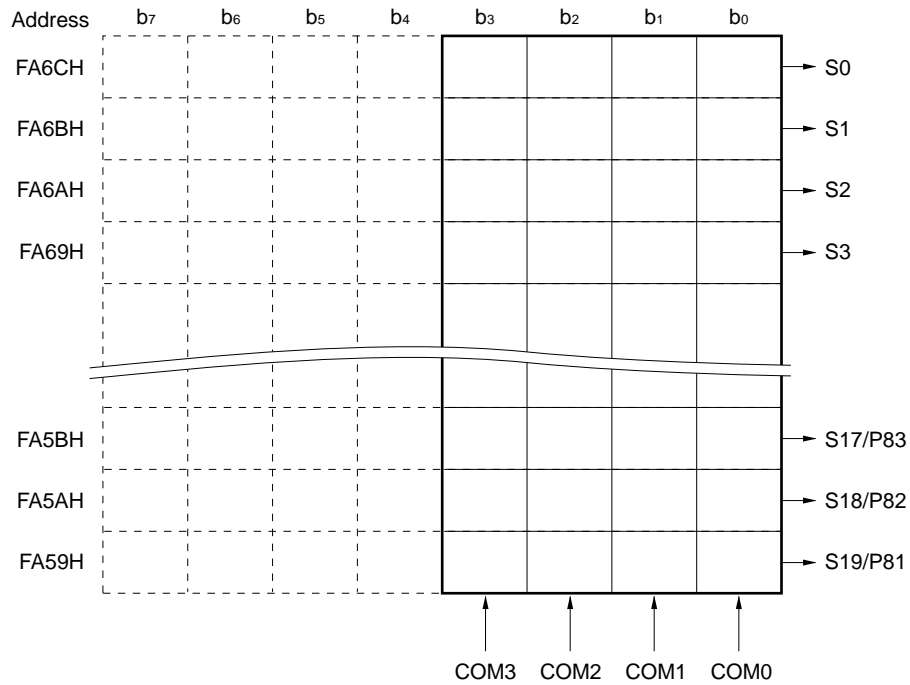

Caution The higher 4 bits of the LCD display data memory do not incorporate memory. Be sure to set them to 0.

16.6 Common Signals and Segment Signals

An individual pixel on an LCD panel lights when the potential difference of the corresponding common signal and segment signal reaches or exceeds a given voltage (the LCD drive voltage V_{LCD}). The light goes off when the potential difference becomes V_{LCD} or lower.

As an LCD panel deteriorates if a DC voltage is applied in the common signals and segment signals, it is driven by AC voltage.

(1) Common signals

For common signals, the selection timing order is as shown in Table 16-3, and operations are repeated with these as the cycle.

Table 16-3. COM Signals

COM signal	COM0	COM1	COM2	COM3
Time division				
4-time division				

(2) Segment signals

Segment signals correspond to a 20-byte LCD display data memory (FA59H to FA6CH). Each display data memory bit 0, bit 1, bit 2, and bit 3 is read in synchronization with the COM0, COM1, COM2 and COM3 timings respectively, and if the value of the bit is 1, it is converted to the selection voltage. If the value of the bit is 0, it is converted to the non-selection voltage and output to a segment pin (S0 to S19) (S18 to S5 have an alternate function as input/output port pins).

Consequently, it is necessary to check what combination of front surface electrodes (corresponding to the segment signals) and rear surface electrodes (corresponding to the common signals) of the LCD panel to be used form the display pattern, and then write bit data corresponding on a one-to-one basis with the pattern to be displayed.

Bits 4 to 7 are fixed at 0.

(3) Common signal and segment signal output waveforms

The voltages shown in Table 16-4 are output in the common signals and segment signals.

The $\pm V_{LCD}$ ON voltage is only produced when the common signal and segment signal are both at the selection voltage; other combinations produce the OFF voltage.

Table 16-4. LCD Drive Voltage

Common \ Segment		Select Level	Non-Select Level
		V_{SS1}, V_{LC0}	V_{LC1}, V_{LC2}
Select level	V_{LC0}, V_{SS1}	$-V_{LCD}, +V_{LCD}$	$-1/3V_{LCD}, +1/3V_{LCD}$
Non-select level	V_{LC2}, V_{LC1}	$-1/3V_{LCD}, +1/3V_{LCD}$	$-1/3V_{LCD}, +1/3V_{LCD}$

Figure 16-6 shows the common signal waveform, and Figure 16-7 shows the common signal and segment signal voltages and phases.

Figure 16-6. Common Signal Waveform

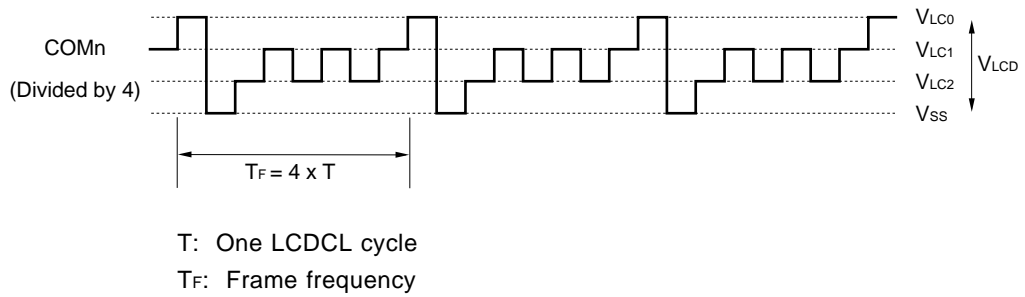
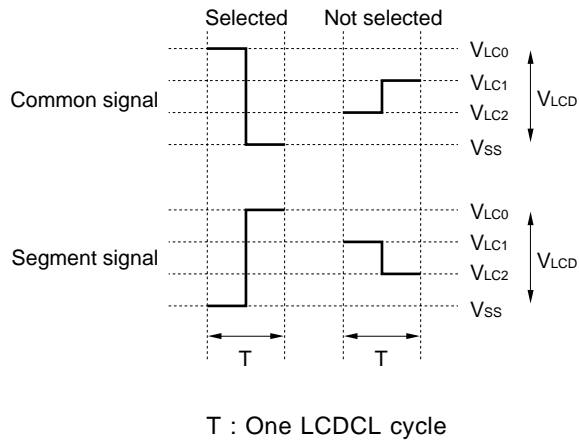

Figure 16-7. Common Signal and Segment Signal Voltages and Phases



16.7 Supplying LCD Drive Voltage V_{LC0} , V_{LC1} , and V_{LC2}

The μ PD780973 Subseries have a split resistor to create an LCD drive voltage, and the drive voltage is fixed to 1/3 bias.

To supply various LCD drive voltages, internal V_{DD} or external V_{LCD} supply voltage can be selected.

Table 16-5. LCD Drive Voltage

Bias Method LCD Drive Voltage	1/3 Bias Method
V_{LC0}	V_{LCD}
V_{LC1}	$2/3 V_{LCD}$
V_{LC2}	$1/3 V_{LCD}$

Figure 16-8 shows an example of supplying an LCD drive voltage from an internal source according to Table 16-5. By using variable resistors r_1 and r_2 , a non-stepwise LCD drive voltage can be supplied.

Figure 16-8. Example of Connection of LCD Drive Power Supply

(a) To supply LCD drive voltage from V_{DD}

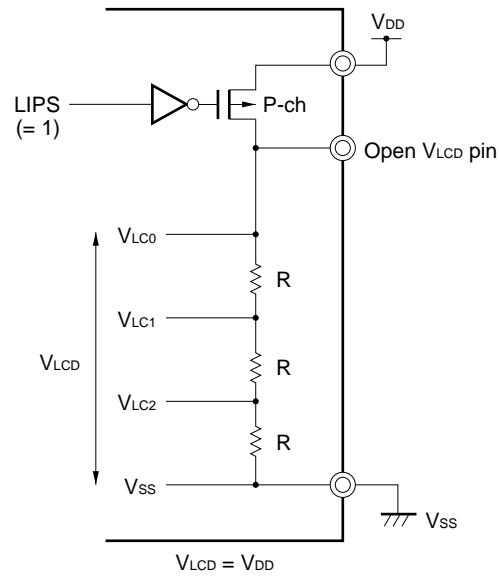

(b) To supply LCD drive voltage from external source

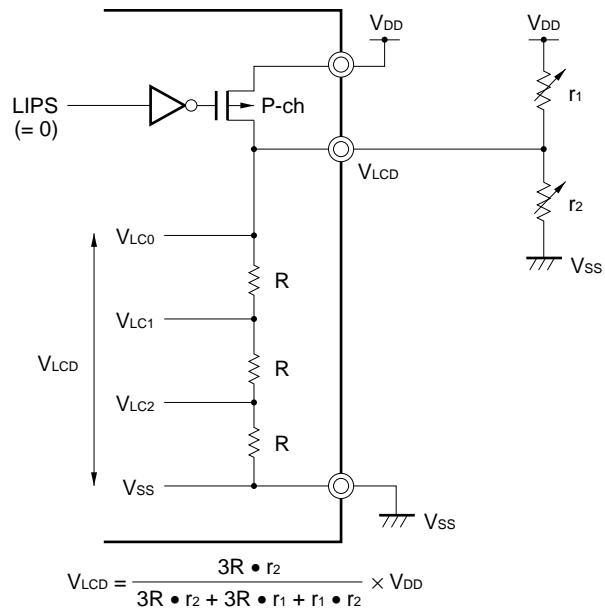

16.8 Display Mode

16.8.1 4-time-division display example

Figure 16-10 shows the connection of a 4-time-division type 10-digit LCD panel with the display pattern shown in Figure 16-9 with the μ PD780973 Subseries segment signals (S0 to S19) and common signals (COM0 to COM3). The display example is “1234567890,” and the display data memory contents (addresses FA59H to FA6CH) correspond to this.

An explanation is given here taking the example of the 5th digit “6” (6). In accordance with the display pattern in Figure 16-9, selection and non-selection voltages must be output to pins S8 and S9 as shown in Table 16-6 at the COM0 to COM3 common signal timings.

Table 16-6. Selection and Non-Selection Voltages (COM0 to COM3)

Segment	S8	S9
Common		
COM0	S	S
COM1	NS	S
COM2	S	S
COM3	NS	S

S: Selection, NS: Non-selection

From this, it can be seen that 0101 must be prepared in the display data memory (address FA64H) corresponding to S8.

Examples of the LCD drive waveforms between S8 and the COM0 and COM1 signals are shown in Figure 16-11 (for the sake of simplicity, waveforms for COM2 and COM3 have been omitted). When S8 is at the selection voltage at the COM0 selection timing, it can be seen that the $+V_{LCD}/-V_{LCD}$ AC square wave, which is the LCD illumination (ON) level, is generated.

Figure 16-9. 4-Time-Division LCD Display Pattern and Electrode Connections

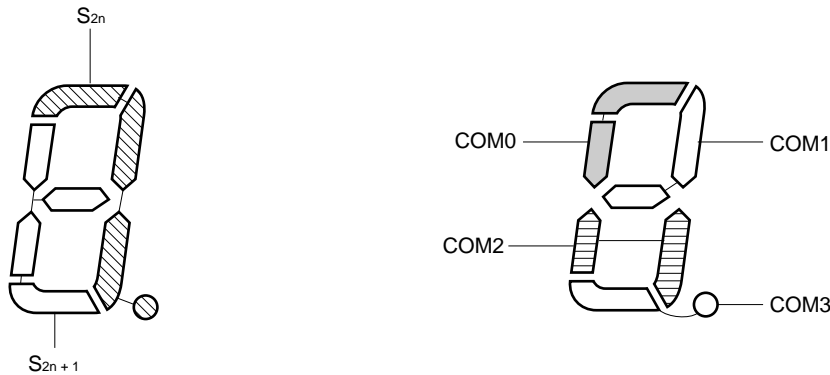

$n = 0$ to 9

Figure 16-10. 4-Time-Division LCD Panel Connection Example

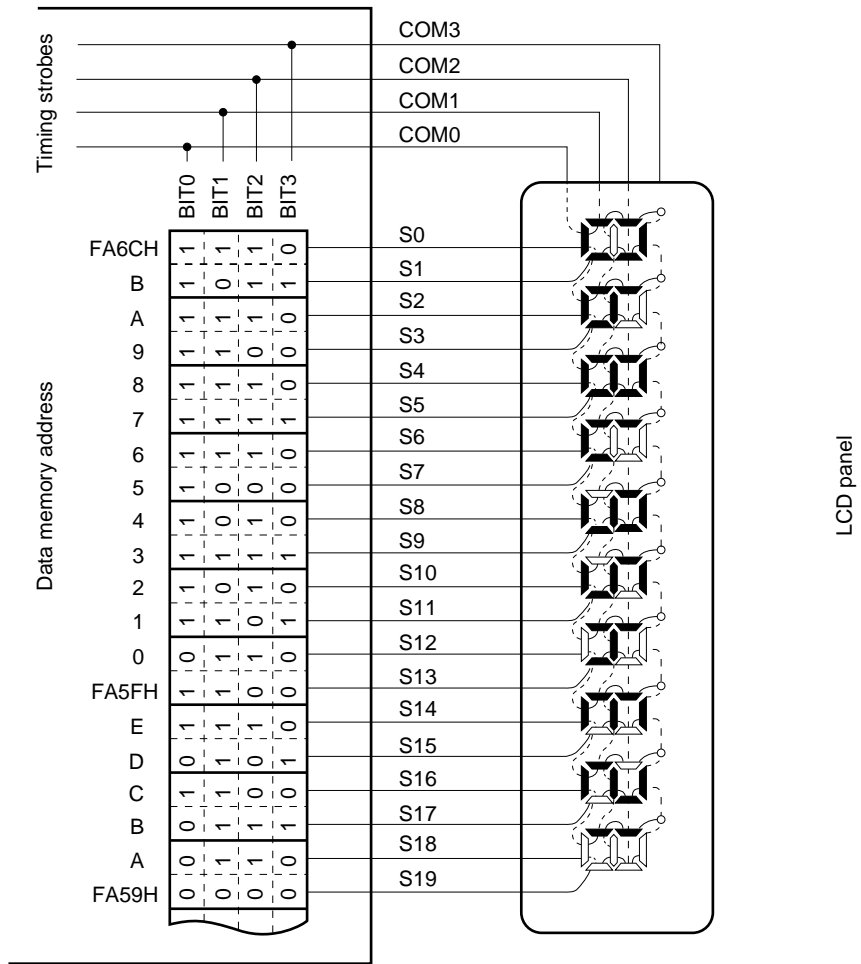
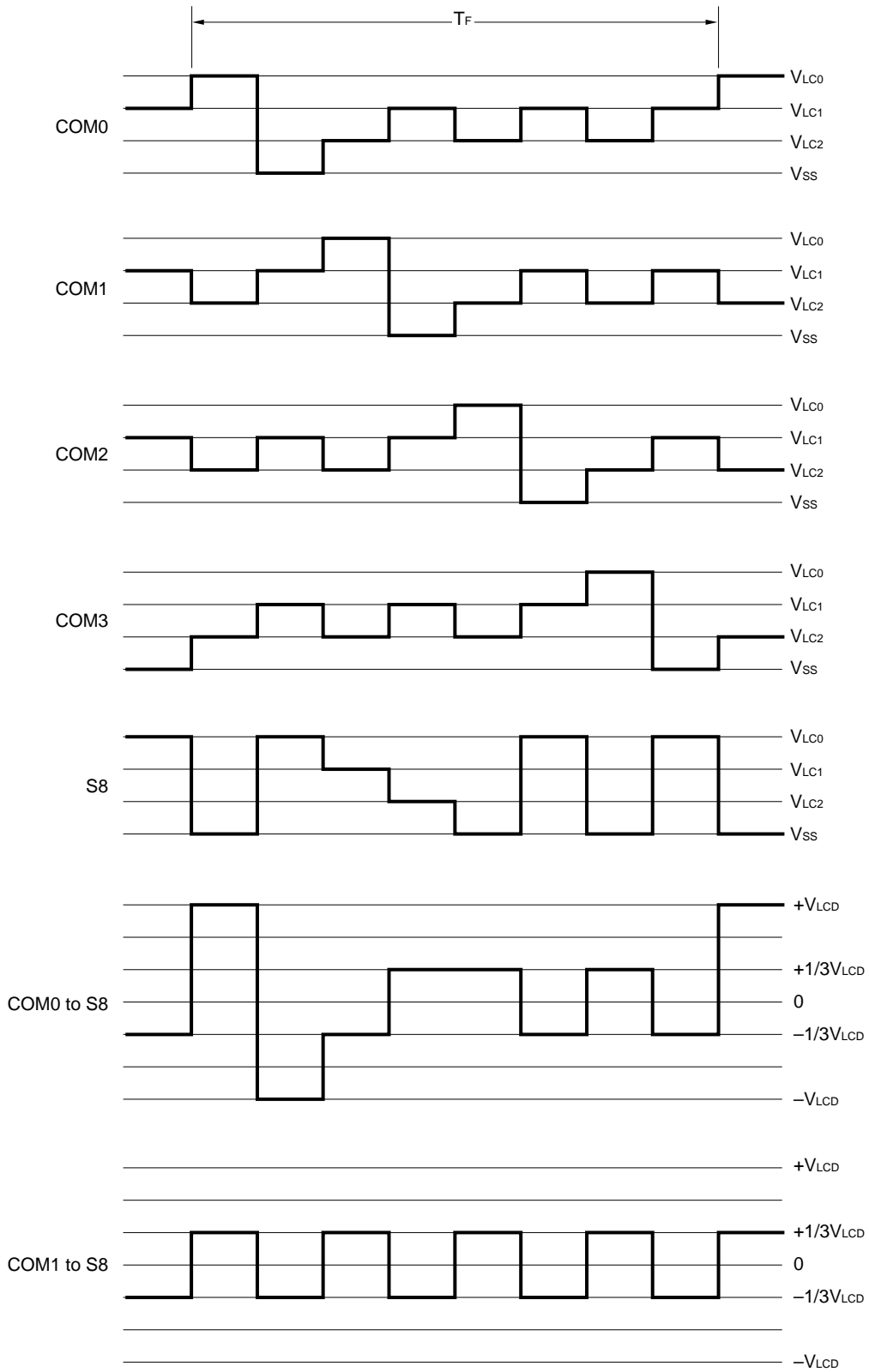

Figure 16-11. 4-Time-Division LCD Drive Waveform Examples (1/3 Bias Method)



★ **16.9 Cautions on Emulation****(1) LCD timer control register (LCDTM)**

To perform debugging with an in-circuit emulator (IE-78K0-NS), the LCD timer control register (LCDTM) must be set. LCDTM is a register used to set a probe board (IE-780974-NS-EM1).

LCDTM is a write-only register that controls supply of the LCD clock. Unless LCDTM is set, the LCD controller/driver does not operate. Therefore, set bit 1 (TMC21) of LCDTM to 1 when using the LCD controller/driver.

Figure 16-12. LCD Timer Control Register (LCDTM) Format

Address: FF4AH After Reset: 00H W

Symbol	7	6	5	4	3	2	1	0
LCDTM	0	0	0	0	0	0	TMC21	0

TMC21	LCD Clock Supply Control
0	LCD controller/driver stop mode (supply of LCD clock is stopped)
1	LCD controller/driver operating mode (supply of LCD clock is enabled)

- Cautions**
- LCDTM is a special register that must be set when debugging is performed with an in-circuit emulator. Even if this register is used, the operation of the μ PD780973 Subseries is not affected. However, delete the instruction that manipulates this register from the program at the final stage of debugging.**
 - Bits 7 to 2, and bit 0 must be set to 0.**

[MEMO]

CHAPTER 17 SOUND GENERATOR

17.1 Sound Generator Function

The sound generator has the function to sound the buzzer from an external speaker, and the following two signals are output.

- ★ **(1) Basic cycle output signal (with/without amplitude)**
 The signal is a buzzer signal with a variable frequency. By setting bits 0 to 2 (SGCLO to SGCL2) of the sound generator control register (SGCR), the signal in a range of 0.25 to 7.7 kHz can be output (when $f_x = 8.38$ MHz). The amplitude of the basic cycle output signal can be varied by ANDing the basic cycle output signal with the 7-bit-resolution PWM signal, to enable control of the buzzer sound volume.
- (2) Amplitude output signal**
 A PWM signal with a 7-bit resolution for variable amplitude can be independently output.

Figure 17-1 shows the sound generator block diagram and Figure 17-2 shows the concept of each signal.

Figure 17-1. Sound Generator Block Diagram

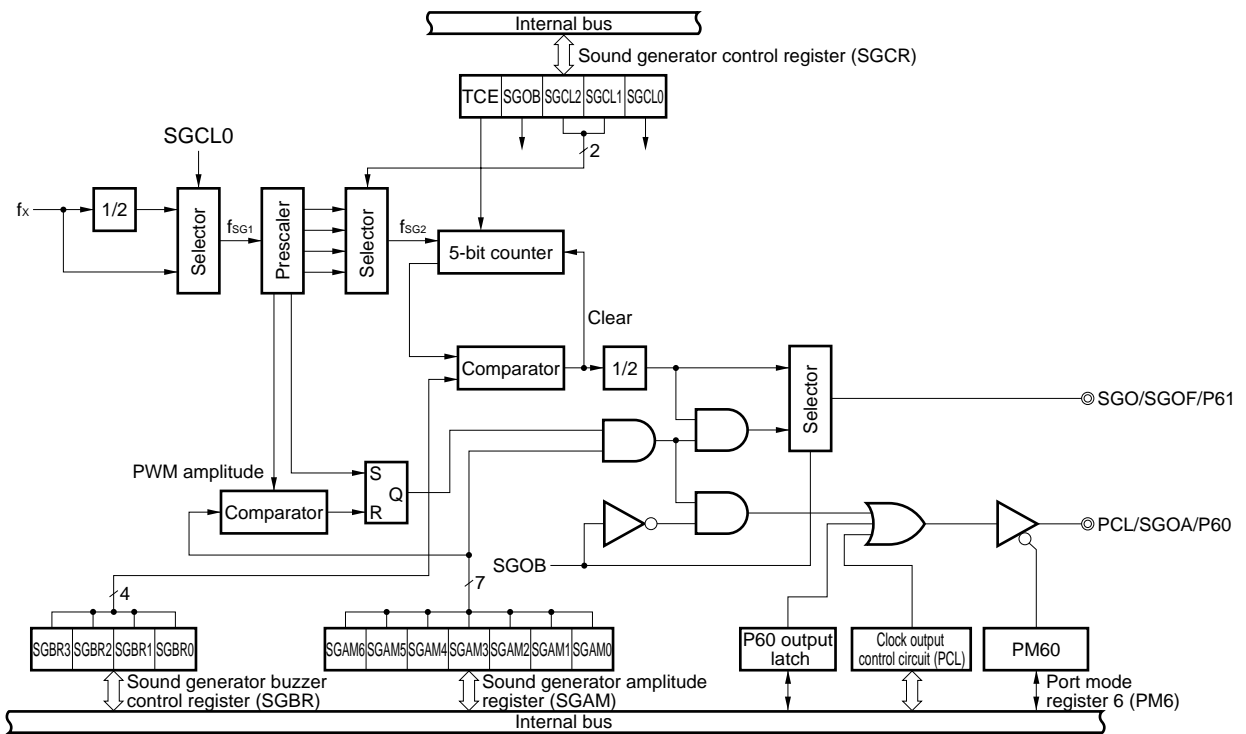
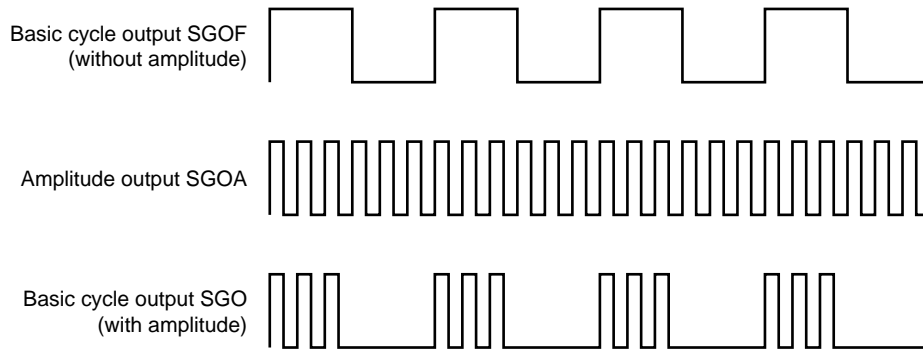

Figure 17-2. Concept of Each Signal



17.2 Sound Generator Configuration

The sound generator consists of the following hardware.

Table 17-1. Sound Generator Configuration

Item	Configuration
Counter	8 bits × 1, 5 bits × 1
SG output	SGO/SGOF (with/without append bit of basic cycle output) SGOA (amplitude output)
Control register	Sound generator control register (SGCR) Sound generator buzzer control register (SGBR) Sound generator amplitude register (SGAM)

17.3 Sound Generator Control Registers

The following three types of registers are used to control the sound generator.

- Sound generator control register (SGCR)
- Sound generator buzzer control register (SGBR)
- Sound generator amplitude register (SGAM)

(1) Sound generator control register (SGCR)

SGCR is a register which sets up the following four types.

- Controls sound generator output
- Selects output of sound generator
- Selects sound generator input frequency f_{SG1}
- Selects 5-bit counter input frequency f_{SG2}

SGCR is set with a 1-bit or 8-bit memory manipulation instruction.

$\overline{\text{RESET}}$ input clears SGCR to 00H.

Figure 17-3 shows the SGCR format.

Figure 17-3. Sound Generator Control Register (SGCR) Format

Address: FF94H After Reset: 00H R/W

Symbol	7	6	5	4	3	2	1	0
SGCR	TCE	0	0	0	SGOB	SGCL2	SGCL1	SGCL0

TCE	Sound Generator Operation Selection
0	Timer operation stopped SGOF/SGO and SGOA for low-level output
1	Sound generator operation SGOF/SGO and SGOA for output

Caution Before setting the TCE bit, set all the other bits.

Remark SGOF: Basic cycle signal (without amplitude)
SGO: Basic cycle signal (with amplitude)
SGOA: Amplitude signal

SGOB	Sound Generator Output Selection
0	Selects SGOF and SGOA outputs
1	Selects SGO and PCL outputs

SGCL2	SGCL1	5-Bit Counter Input Frequency f_{SG2} Selection
0	0	$f_{SG2} = f_{SG1}/2^5$
0	1	$f_{SG2} = f_{SG1}/2^6$
1	0	$f_{SG2} = f_{SG1}/2^7$
1	1	$f_{SG2} = f_{SG1}/2^8$

SGCL0	Sound Generator Input Frequency Selection
0	$f_{SG1} = f_x/2$
1	$f_{SG1} = f_x$

Cautions 1. When rewriting SGCR to other data, stop the timer operation (TCE = 0) beforehand.
2. Bits 4 to 6 must be set to 0.

The maximum and minimum values of the buzzer output frequency are as follows.

SGCL2	SGCL1	SGCL0	Maximum and Minimum Values of Buzzer Output				
			f _{SG2}	f _x = 8 MHz		f _x = 8.38 MHz	
				Max. (kHz)	Min. (kHz)	Max. (kHz)	Min. (kHz)
0	0	0	f _{SG1} /2 ⁶	3.677	1.953	3.851	2.046
0	0	1	f _{SG1} /2 ⁵	7.354	3.906	7.702	4.092
0	1	0	f _{SG1} /2 ⁷	1.838	0.976	1.926	1.024
0	1	1	f _{SG1} /2 ⁶	3.677	1.953	0.481	2.046
1	0	0	f _{SG1} /2 ⁸	0.919	0.488	0.963	0.512
1	0	1	f _{SG1} /2 ⁷	1.838	0.976	1.926	1.024
1	1	0	f _{SG1} /2 ⁹	0.460	0.244	0.481	0.256
1	1	1	f _{SG1} /2 ⁸	0.919	0.488	0.963	0.512

The sound generator output frequency f_{SG} can be calculated by the following expression.

$$f_{SG} = 2^{(SGCL0 - SGCL1 - 2 \times SGCL2 - 7)} \times \{f_x / (SGBR + 17)\}$$

Substitute set 0 or 1 to SGCL0 to SGCL2 in the above expression. Substitute a decimal value to SGBR. Where f_x = 8 MHz, SGCL0 to SGCL2 is (1, 0, 0), and SGBR0 to SGBR3 is (1, 1, 1, 1), SGBR = 15. Therefore,

$$\begin{aligned} f_{SG} &= 2^{(1 - 0 - 2 \times 0 - 7)} \times \{f_x / (15 + 17)\} \\ &= 3.906 \text{ kHz} \end{aligned}$$

(2) Sound generator buzzer control register (SGBR)

SGBR is a register that sets the basic frequency of the sound generator output signal.

SGBR is set with a 1-bit or 8-bit memory manipulation instruction.

$\overline{\text{RESET}}$ input clears SGBR to 00H.

Figure 17-4 shows the SGBR format.

Figure 17-4. Sound Generator Buzzer Control Register (SGBR) Format

Address: FF95H After Reset: 00H R/W

Symbol	7	6	5	4	3	2	1	0
SGBR	0	0	0	0	SGBR3	SGBR2	SGBR1	SGBR0

SGBR3	SGBR2	SGBR1	SGBR0	Buzzer Output Frequency (kHz) ^{Note}	
				f _x = 8 MHz	f _x = 8.38 MHz
0	0	0	0	3.677	3.851
0	0	0	1	3.472	3.637
0	0	1	0	3.290	3.446
0	0	1	1	3.125	3.273
0	1	0	0	2.976	3.117
0	1	0	1	2.841	2.976
0	1	1	0	2.717	2.847
0	1	1	1	2.604	2.728
1	0	0	0	2.500	2.619
1	0	0	1	2.404	2.518
1	0	1	0	2.315	2.425
1	0	1	1	2.232	2.339
1	1	0	0	2.155	2.258
1	1	0	1	2.083	2.182
1	1	1	0	2.016	2.112
1	1	1	1	1.953	2.046

Note Output frequency where SGCL0, SGCL1, and SGCL2 are 0, 0, and 0.

- Cautions 1. When rewriting SGBR to other data, stop the timer operation (TCE = 0) beforehand.**
- 2. Bits 4 to 7 must be set to 0.**

(3) Sound generator amplitude register (SGAM)

SGAM is a register that sets the amplitude of the sound generator output signal.

SGAM is set with a 1-bit or 8-bit memory manipulation instruction.

RESET input clears SGAM to 00H.

Figure 17-5 shows the SGAM format.

Figure 17-5. Sound Generator Amplitude Register (SGAM) Format

Address: FF96H After Reset: 00H R/W

Symbol	7	6	5	4	3	2	1	0
SGAM	0	SGAM6	SGAM5	SGAM4	SGAM3	SGAM2	SGAM1	SGAM0

SGAM6	SGAM5	SGAM4	SGAM3	SGAM2	SGAM1	SGAM0	Amplitude
0	0	0	0	0	0	0	0/128
0	0	0	0	0	0	1	2/128
0	0	0	0	0	1	0	3/128
0	0	0	0	0	1	1	4/128
0	0	0	0	1	0	0	5/128
0	0	0	0	1	0	1	6/128
0	0	0	0	1	1	0	7/128
0	0	0	0	1	1	1	8/128
0	0	0	1	0	0	0	9/128
0	0	0	1	0	0	1	10/128
0	0	0	1	0	1	0	11/128
0	0	0	1	0	1	1	12/128
0	0	0	1	1	0	0	13/128
0	0	0	1	1	0	1	14/128
0	0	0	1	1	1	0	15/128
0	0	0	1	1	1	1	16/128
0	0	1	0	0	0	0	17/128
0	0	1	0	0	0	1	18/128
0	0	1	0	0	1	0	19/128
0	0	1	0	0	1	1	20/128
0	0	1	0	1	0	0	21/128
0	0	1	0	1	0	1	22/128
0	0	1	0	1	1	0	23/128
0	0	1	0	1	1	1	24/128
0	0	1	1	0	0	0	25/128
0	0	1	1	0	0	1	26/128
0	0	1	1	0	1	0	27/128
0	0	1	1	0	1	1	28/128
0	0	1	1	1	0	0	29/128
0	0	1	1	1	0	1	30/128
0	0	1	1	1	1	0	31/128
⋮							⋮
1	1	1	1	1	1	1	128/128

Cautions 1. When rewriting the contents of SGAM, the timer operation does not need to be stopped. However, note that a high level may be output for one period due to rewrite timing.

2. Bit 7 must be set to 0.

17.4 Sound Generator Operations

17.4.1 To output basic cycle signal SGOF (without amplitude)

Select SGOF output by setting bit 3 (SGOB) of the sound generator control register (SGCR) to "0".

The basic cycle signal with a frequency specified by the SGCL0 to SGCL2 and SGBR0 to SGBR3 is output.

At the same time, the amplitude signal with an amplitude specified by the SGAM0 to SGAM6 is output from the SGOA pin.

Figure 17-6. Sound Generator Output Operation Timing

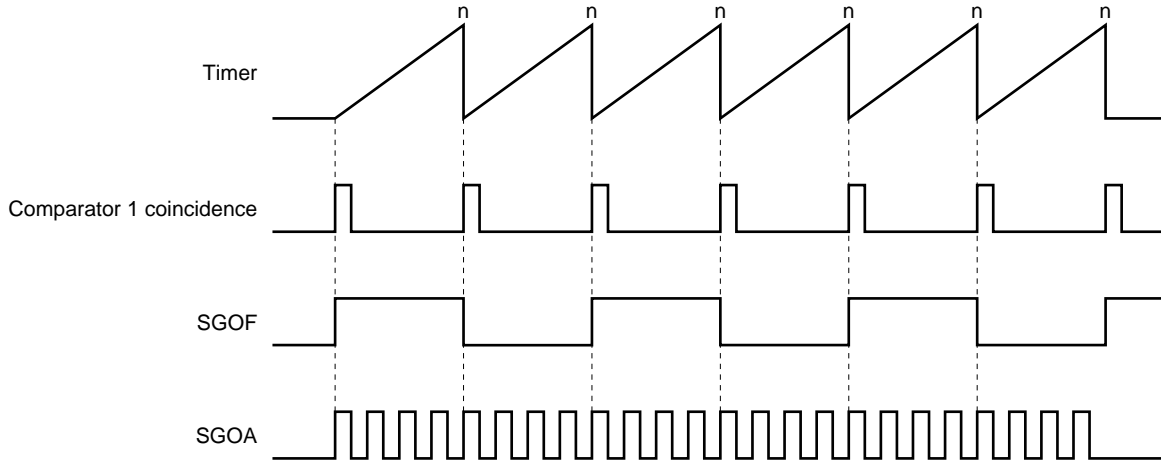

17.4.2 To output basic cycle signal SGO (with amplitude)

Select SGO output by setting bit 3 (SGOB) of the sound generator control register (SGCR) to "1".

The basic cycle signal with a frequency specified by the SGCL0 to SGCL2 and SGBR0 to SGBR3 is output.

When SGO output is selected, the SGOA pin can be used as a PCL output (clock output) or I/O port pin.

Figure 17-7. Sound Generator Output Operation Timing

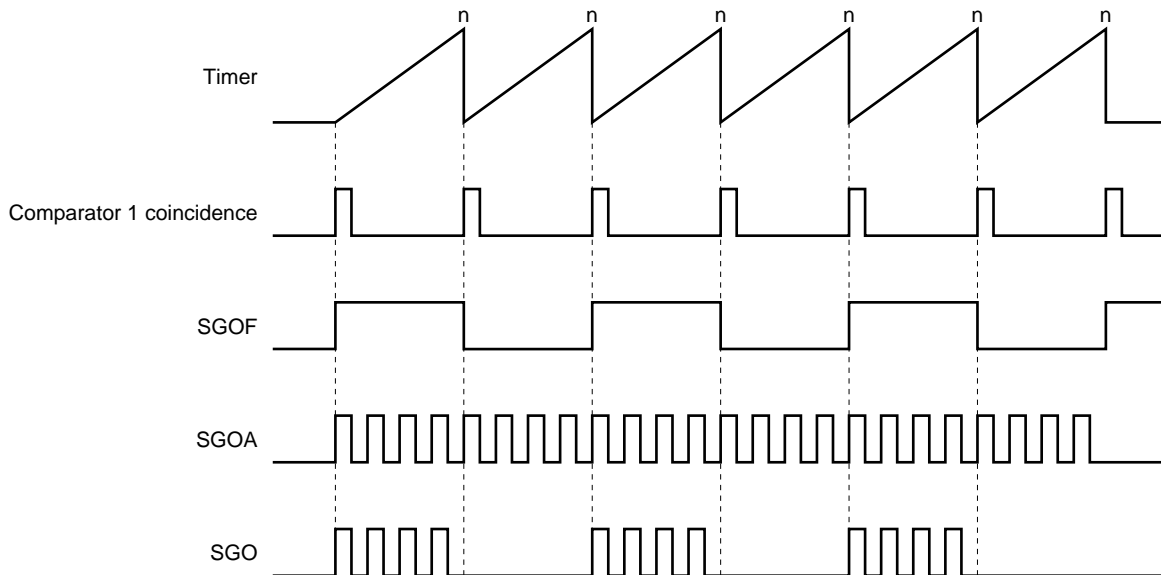

CHAPTER 18 METER CONTROLLER/DRIVER

18.1 Meter Controller/Driver Functions

The meter controller/driver is a function to drive a stepping motor for external meter control or cross coil.

- Can set pulse width with a precision of 8 bits
- Can set pulse width with a precision of 8 + 1 bits with 1-bit addition function
- Can drive up to four 360° type meters

Figure 18-1 shows the block diagram of the meter controller/driver, Figure 18-2 shows 1-bit addition circuit block diagram.

Figure 18-1. Meter Controller/Driver Block Diagram

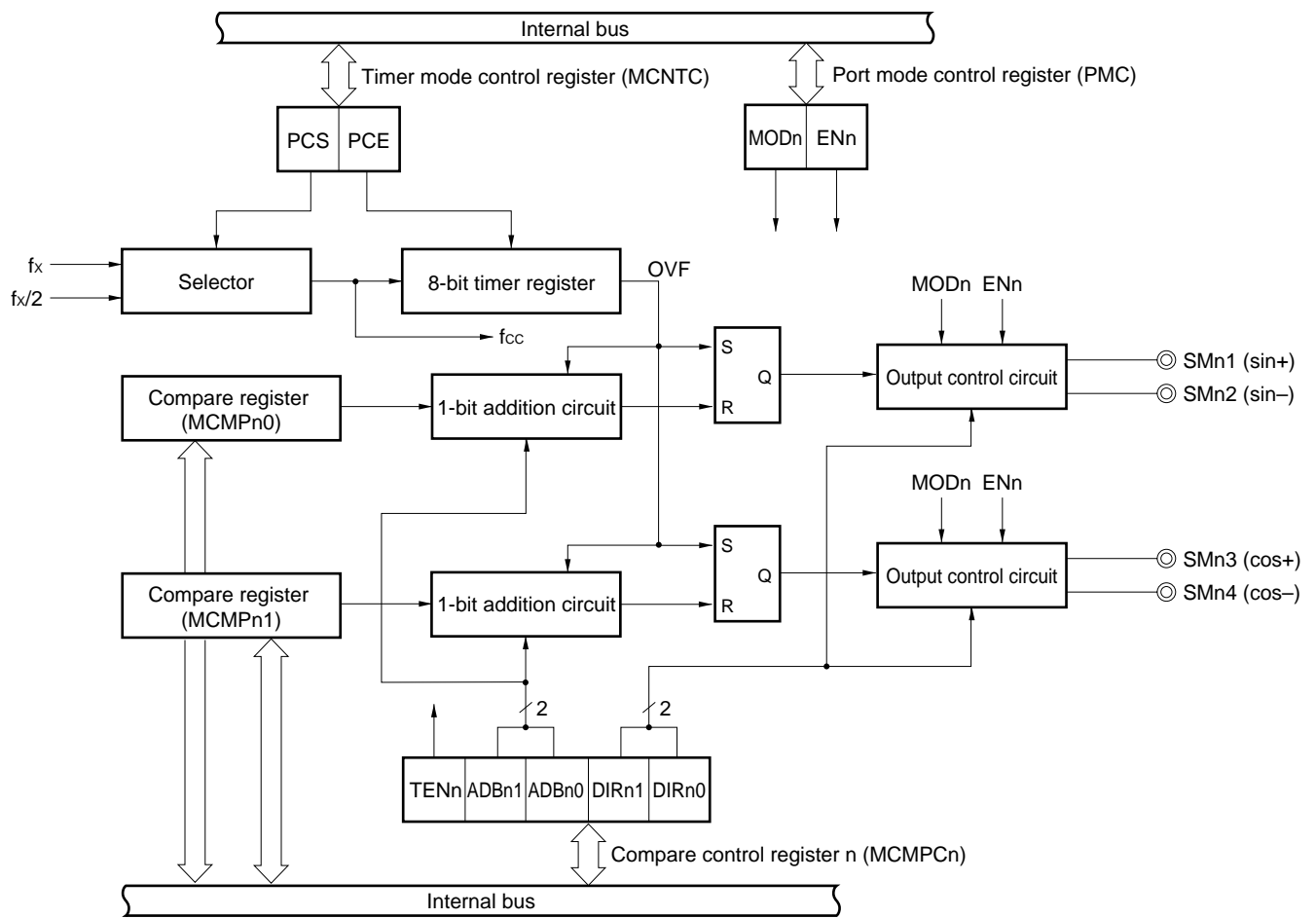

Remark n = 1 to 4

Figure 18-2. 1-Bit Addition Circuit Block Diagram

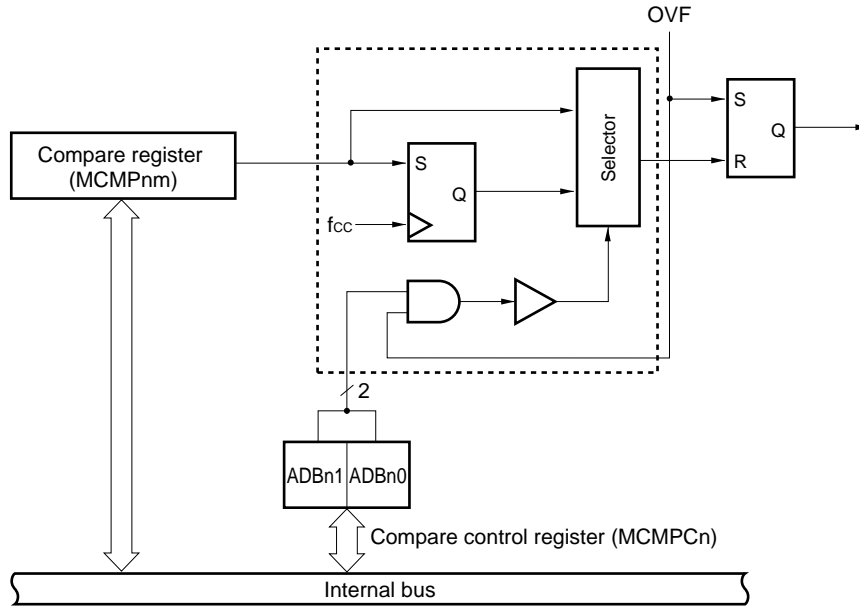

Remark n = 1 to 4, m = 0, 1

18.2 Meter Controller/Driver Configuration

The meter controller/driver consists of the following hardware.

Table 18-1. Meter Controller/Driver Configuration

Item	Configuration
Timer	Free-running up counter (MCNT): 1 channel
Register	Compare register (MCMPn1, MCMPn0): 8 channels
Control registers	Timer mode control register (MCNTC) Compare control register n (MCMPn) Port mode control register (PMC)
Pulse control circuit	1-bit addition circuit/output control circuit

Remark n = 1 to 4

(1) Free running up counter (MCNT)

MCNT is an 8-bit free running up counter, and is a register that executes increment at the rising edge of input clock.

A PWM pulse with a resolution of 8 bits can be output. The duty factor can be set in a range of 0 to 100%. The count value is cleared in the following cases.

- When $\overline{\text{RESET}}$ signal input
- When counter stops (PCE = 0)

- ★ **Cautions**
1. MCNT executes counting operation from 01H to FFH repeatedly. However, it counts from 00H upon operation start.
 2. The PWM output is not output until the first overflow of MCNT.

(2) Compare register n0 (MCMPn0)

MCMPn0 is an 8-bit register that can rewrite compare values through specification of bit 4 (TENn) of the compare control register n (MCMPCn).

$\overline{\text{RESET}}$ input sets this register to 00H and clears hardware to 0.

MCMPn0 is a register that supports read/write only for 8-bit access instructions. MCMPn0 continuously compares its value with the MCNT value. When the above two values match, a match signal of the sin side of meter n is generated.

(3) Compare register n1 (MCMPn1)

MCMPn1 is an 8-bit register that can rewrite compare values through specification of bit 4 (TENn) of the compare control register n (MCMPCn).

$\overline{\text{RESET}}$ input sets this register to 00H and clears hardware to 0.

MCMPn1 is a register that supports read/write only for 8-bit access instructions. MCMPn1 continuously compares its value with the MCNT value. When the above two values match, a match signal of the cos side of meter n is generated.

(4) 1-bit addition circuit

The 1-bit addition circuit repeats 1-bit addition/non-addition to PWM output alternately upon MCNT overflow output, and enables the state of PWM output between current compare value and the next compare value. This circuit is controlled by bits 2 and 3 (ADBn0, ADBn1) of the MCMPCn register.

(5) Output control circuit

This circuit consists of a Pch and Nch drivers and can drive a meter in H bridge configuration by connecting a coil. When a meter is driven in half bridge configuration, the unused pins can be used as normal output port pins.

The relation of the duty factor of the PWM signal output from the SMnm pin is indicated by the following expression (n = 1 to 4, m = 0, 1).

$$\begin{aligned} \text{PWM (duty)} &= \frac{\text{Set value of MCMPnm} \times \text{cycle of MCNT count clock}}{255 \times \text{cycle of MCNT count clock}} \times 100\% \\ &= \frac{\text{Set value of MCMPnm}}{255} \times 100\% \end{aligned}$$

- Cautions**
1. MCMPn0 and MCMPn1 cannot be read or written by a 16-bit access instruction.
 2. MCMPn0 and MCMPn1 are in master-slave configuration, and MCNT is compared with a slave register. The PWM pulse is not output until the first overflow occurs after the counting operation has been started because the compare data is not transferred to the slave.

18.3 Meter Controller/Driver Control Registers

The meter controller/driver is controlled by the following three registers.

- Timer mode control register (MCNTC)
- Compare control register n (MCMPCn)
- Port mode control register (PMC)

Remark n = 1 to 4

(1) Timer mode control register (MCNTC)

MCNTC is an 8-bit register that controls the operation of the free-running up counter (MCNT).

MCNTC is set with an 8-bit memory manipulation instruction.

RESET input clears MCNTC to 00H.

Figure 18-3 shows the MCNTC format.

Figure 18-3. Timer Mode Control Register (MCNTC) Format

Address: FF69H After Reset: 00H R/W

Symbol	7	6	5	4	3	2	1	0
MCNTC	0	0	PCS	PCE	0	0	0	0
PCS	Timer Counter Clock Selection							
0	fx							
1	fx/2							
PCE	Timer Operation Control							
0	Operation stopped (timer value is cleared)							
1	Operation enabled							

- Cautions**
1. When rewriting MCNTC to other data, stop the timer operation (PCE = 0) beforehand.
 2. Bits 0 to 3, 6, and 7 must be set to 0.

(2) Compare control register (MCMPCn)

MCMPCn is an 8-bit register that controls the operation of the compare register and output direction of the PWM pin.

MCMPCn is set with an 8-bit memory manipulation instruction.

RESET input clears MCMPCn to 00H.

Figure 18-4 shows the MCMPCn format.

Figure 18-4. Compare Control Register n (MCMPCn) Format

Address: FF6BH to FF6EH After Reset: 00H R/W

Symbol	7	6	5	4	3	2	1	0
MCMPCn (n = 1 to 4)	0	0	0	TENn	ADbn1	ADbn0	DIRn1	DIRn0

TENn Note	Enables Transfer by Register from Master to Slave
0	Disables data transfer from master to slave. New data can be written.
1	Transfer data from master to slave when MCNT overflows. New data cannot be written.

ADbn1	Control of 1-bit addition circuit (cos side of meter n)
0	No 1-bit addition to PWM output
1	1-bit addition to PWM output

ADbn0	Control of 1-bit addition circuit (sin side of meter n)
0	No 1-bit addition to PWM output
1	1-bit addition to PWM output

Note TENn functions as a control bit and status flag.

As soon as the timer overflows and PWM data is output, TENn is cleared to “0” by hardware.

The relation among the DIRn1 and DIRn0 bits of the MCMPCn register and output pin is shown below.

DIRn1	DIRn0	Direction Control Bit			
		SMn1	SMn2	SMn3	SMn4
0	0	PWM	0	PWM	0
0	1	PWM	0	0	PWM
1	0	0	PWM	0	PWM
1	1	0	PWM	PWM	0

Caution Bits 5 to 7 must be set to 0.

(3) Port mode control register (PMC)

PMC is an 8-bit register that specifies PWM/PORT output.

PMC is set with an 8-bit memory manipulation instruction.

RESET input clears PMC to 00H.

Figure 18-5 shows the PMC format.

Figure 18-5. Port Mode Control Register (PMC) Format

Address: FF6AH After Reset: 00H R/W

Symbol	7	6	5	4	3	2	1	0
PMC	MOD4	MOD3	MOD2	MOD1	EN4	EN3	EN2	EN1
	MOD4	Meter 4 Full/Half Bridge Selection						
	0	Meter 4 output is full bridge.						
	1	Meter 4 output is half bridge.						
	MOD3	Meter 3 Full/Half Bridge Selection						
	0	Meter 3 output is full bridge.						
	1	Meter 3 output is half bridge.						
	MOD2	Meter 2 Full/Half Bridge Selection						
	0	Meter 2 output is full bridge.						
	1	Meter 2 output is half bridge.						
	MOD1	Meter 1 Full/Half Bridge Selection						
	0	Meter 1 output is full bridge.						
	1	Meter 1 output is half bridge.						
	EN4	Meter 4 Port/PWM Mode Selection						
	0	Meter 4 output is in port mode.						
	1	Meter 4 output is in PWM mode.						
	EN3	Meter 3 Port/PWM Mode Selection						
	0	Meter 3 output is in port mode.						
	1	Meter 3 output is in PWM mode.						
	EN2	Meter 2 Port/PWM Mode Selection						
	0	Meter 2 output is in port mode.						
	1	Meter 2 output is in PWM mode.						
	EN1	Meter 1 Port/PWM Mode Selection						
	0	Meter 1 output is in port mode.						
	1	Meter 1 output is in PWM mode.						

The relation among the ENn and MODn bits of the PMC register, DIRn1 and DIRn0 bits of the MCMPCn register, and output pins is shown below.

ENn	MODn	DIRn1	DIRn0	SMn1 (sin+)	SMn2 (sin-)	SMn3 (cos+)	SMn4 (cos-)	Mode
0	×	×	×	PORT	PORT	PORT	PORT	Port mode
1	0	0	0	PWM	0	PWM	0	PWM mode full bridge
1	0	0	1	PWM	0	0	PWM	
1	0	1	0	0	PWM	0	PWM	
1	0	1	1	0	PWM	PWM	0	
1	1	0	0	PWM	PORT	PWM	PORT	PWM mode half bridge
1	1	0	1	PWM	PORT	PORT	PWM	
1	1	1	0	PORT	PWM	PORT	PWM	
1	1	1	1	PORT	PWM	PWM	PORT	

DIRn1 and DIRn0 mean the quadrant of sin and cos, and DIRn1, DIRn0 = 00 through 11 correspond to quadrants 1 through 4, respectively. The PWM signal is output to the specific pin of the + and – polarities of sin and cos of each quadrant.

When ENn = 0, all the output pins are used as port pins regardless of MODn, DIRn1, and DIRn0.

When ENn = 1 and MODn = 0, the full bridge mode is set, and 0 is output to a pin that does not output a PWM signal.

When ENn = 1 and MODn = 1, the half bridge mode is set, and the pin that does not output a PWM signal is used as a port pin.

Caution The output polarity of the PWM output changes when MCNT overflows.

18.4 Meter Controller/Driver Operations

18.4.1 Basic operation of free-running up counter (MCNT)

The free-running up counter is counted up by the count clock selected by the PCS bit of the timer mode control register.

The value of MCNT is cleared by $\overline{\text{RESET}}$ input.

The counting operation is enabled or disabled by the PCE bit of the timer mode control register (MCNTC).

Figure 18-6 shows the timing from count start to restart.

Figure 18-6. Restart Timing after Count Stop (Count Start→Count Stop→Count Start)

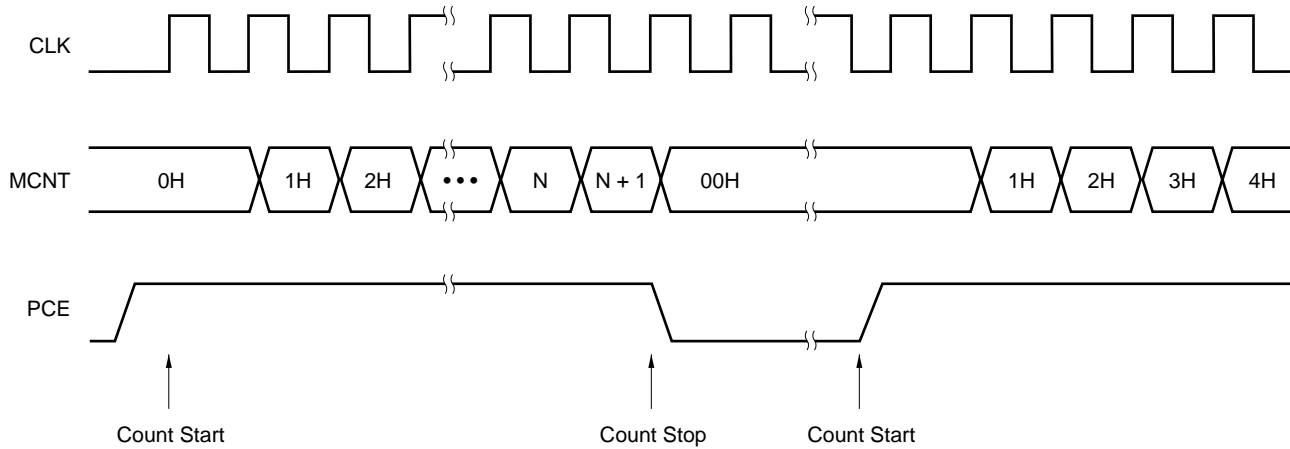

Remark N = 00H to FFH

18.4.2 To update PWM data

Confirm that bit 4 (TENn) of MCMPn is 0, and then set 8-bit PWM data to MCMPn1 and MCMPn0, and bits 2 and 3 (ADbn1 and ADbn0) of MCMPn, and at the same time, set TENn to 1.

The data will be automatically transferred to the slave latch when the timer overflows, and the PWM data becomes valid. At the same time, TENn is automatically cleared to 0.

18.4.3 Operation of 1-bit addition circuit

Figure 18-7. Timing in 1-Bit Addition Circuit Operation

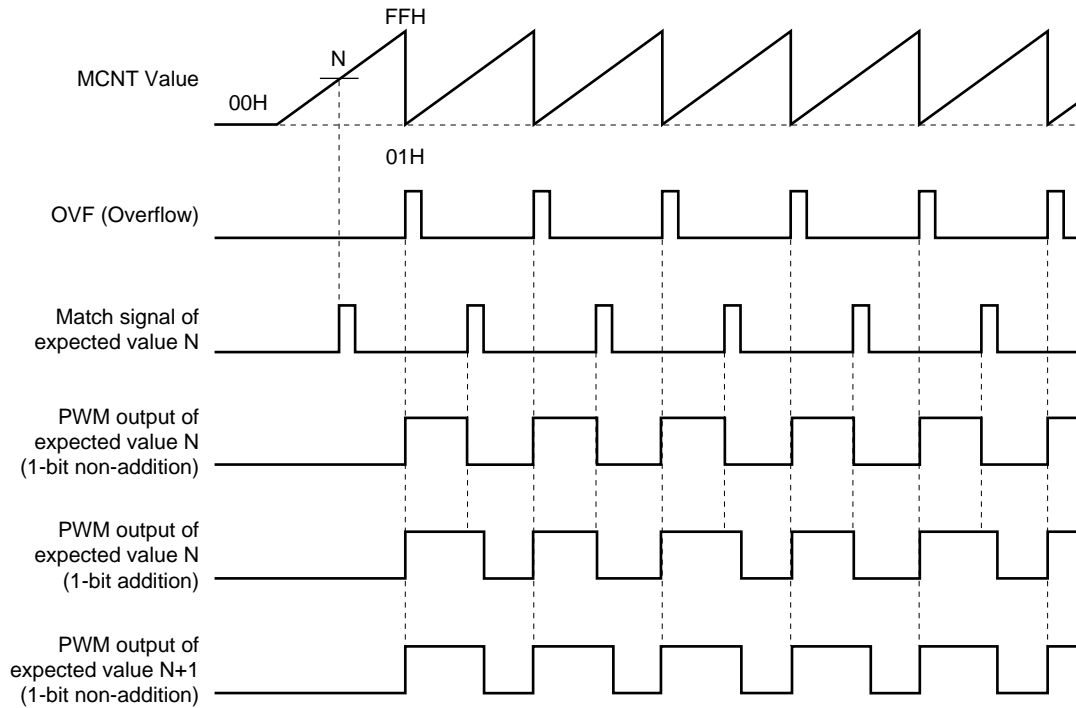

The 1-bit addition mode repeats 1-bit addition/non-addition to PWM output alternately upon MCNT overflow output, and enables the state of PWM output between current compare value N and the next compare value N+1. In this mode, 1-bit addition to the PWM output is set by setting ADBn of the MCMPCn register to 1, and 1-bit non-addition (normal output) is set by setting ADBn to 0.

Remark n = 1 to 4

18.4.4 PWM output operation (output with 1 clock shifted)

Figure 18-8. Timing of Output with 1 Clock Shifted

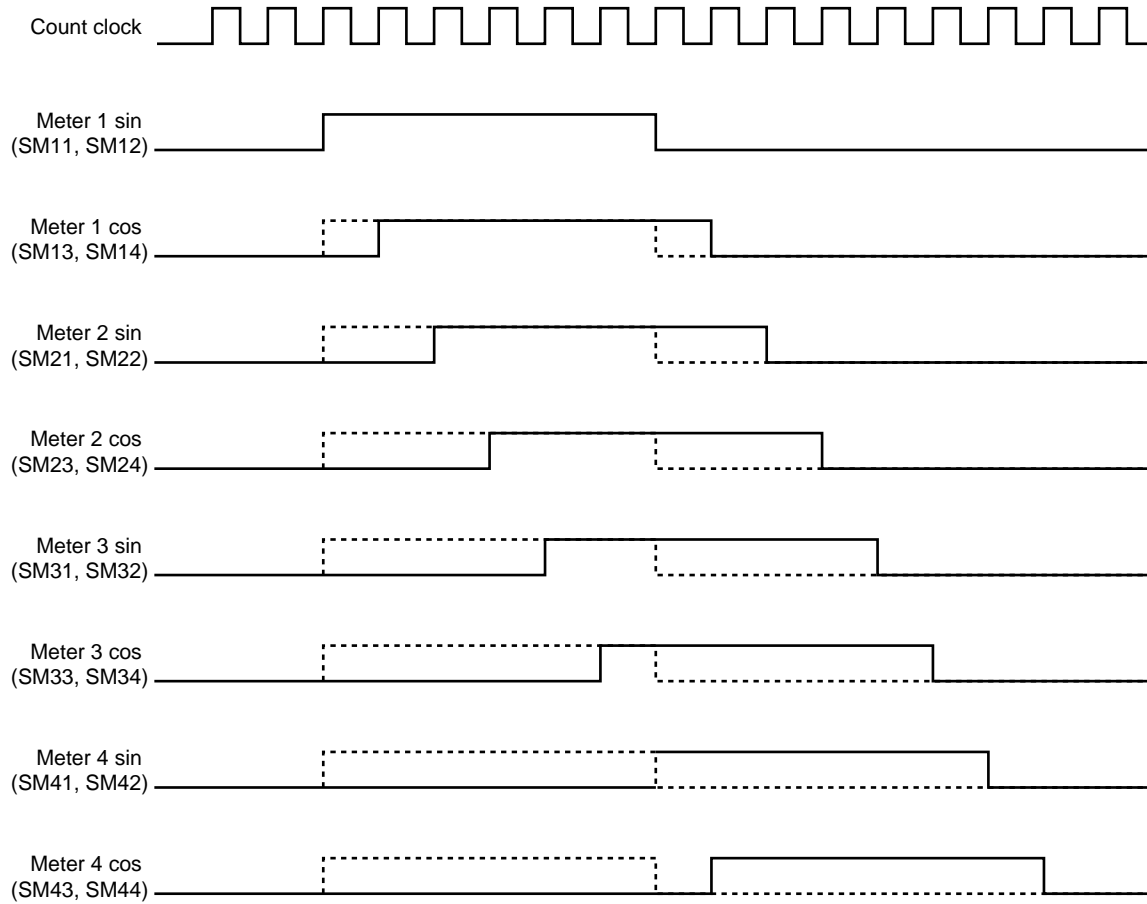

If the wave of sin and cos of meters 1 to 4 rises and falls internally as indicated by the broken line, the SM11 to SM44 pins always shift the count clock by 1 clock and output signals, in order to prevent V_{DD}/GND from fluctuating.

CHAPTER 19 INTERRUPT FUNCTIONS

19.1 Interrupt Function Types

The following three types of interrupt functions are used.

(1) Non-maskable interrupt

This interrupt is acknowledged unconditionally even in the interrupt disabled state. It does not undergo priority control and is given top priority over all other interrupt requests.

A standby release signal is generated.

One interrupt request from the watchdog timer is incorporated as a non-maskable interrupt.

(2) Maskable interrupts

These interrupts undergo mask control. Maskable interrupts can be divided into a high interrupt priority group and a low interrupt priority group by setting the priority specify flag registers (PR0L, PR0H, PR1L).

Multiple high priority interrupts can be applied to low priority interrupts. If two or more interrupts with the same priority are simultaneously generated, each interrupt has a predetermined priority (see **Table 19-1**).

A standby release signal is generated.

Three external interrupt requests and sixteen internal interrupt requests are incorporated as maskable interrupts.

(3) Software interrupt

This is a vectored interrupt to be generated by executing the BRK instruction. It is acknowledged even in the interrupt disabled state. The software interrupt does not undergo interrupt priority control.

19.2 Interrupt Sources and Configuration

A total of 21 interrupt sources exist among non-maskable, maskable, and software interrupts (see **Table 19-1**).

Table 19-1. Interrupt Source List

Interrupt Type	Note 1 Default Priority	Interrupt Source		Internal/ External	Vector Table Address	Basic Configuration Type Note 2
		Name	Trigger			
Non-maskable	—	INTWDT	Watchdog timer overflow (with non-maskable interrupt selected)	Internal	0004H	(A)
Maskable	0	INTWDT	Watchdog timer overflow (with interval timer selected)			Internal
	1	INTAD	End of A/D conversion			
	2	INTOVF	16-bit timer overflow			
	3	INTTM00	TI00 valid edge detection			
	4	INTTM01	TI01 valid edge detection			
	5	INTTM02	TI02 valid edge detection			
	6	INTP0	Pin input edge detection	External	0010H 0012H 0014H	(D)
	7	INTP1				
	8	INTP2				
	9	INTCSI	End of serial interface SIO3 transfer	Internal	0016H 0018H 001AH 001CH 001EH 0020H 0022H 0024H 0026H 0028H	(B)
	10	INTSER	Generation of serial interface UART receive error			
	11	INTSR	End of serial interface UART reception			
	12	INTST	End of serial interface UART transmission			
	13	INTTM1	Generation of 8-bit timer register and capture register (CR1) match signal			
	14	INTTM2	Generation of 8-bit timer register and capture register (CR2) match signal			
	15	INTTM3	Generation of 8-bit timer register and capture register (CR3) match signal			
	16	INTWE	End of EEPROM write			
	17	INTWTI	Watch timer overflow			
18	INTWT	Reference time interval signal from watch timer				
Software	—	BRK	BRK instruction execution	—	003EH	(E)

Notes 1. The default priority is the priority applicable when two or more maskable interrupt requests are generated simultaneously. 0 is the highest priority, and 18 is the lowest.

2. Basic configuration types (A) to (E) correspond to (A) to (E) in Figure 19-1.

Figure 19-1. Basic Configuration of Interrupt Function (1/2)

(A) Internal non-maskable interrupt

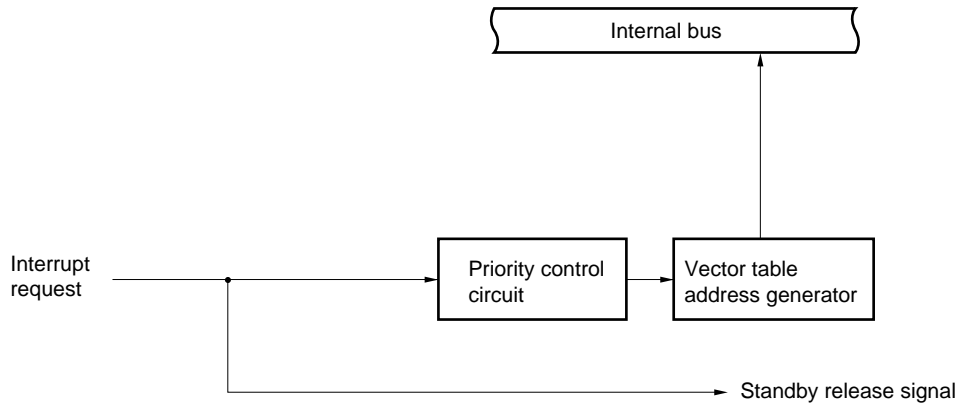

(B) Internal maskable interrupt

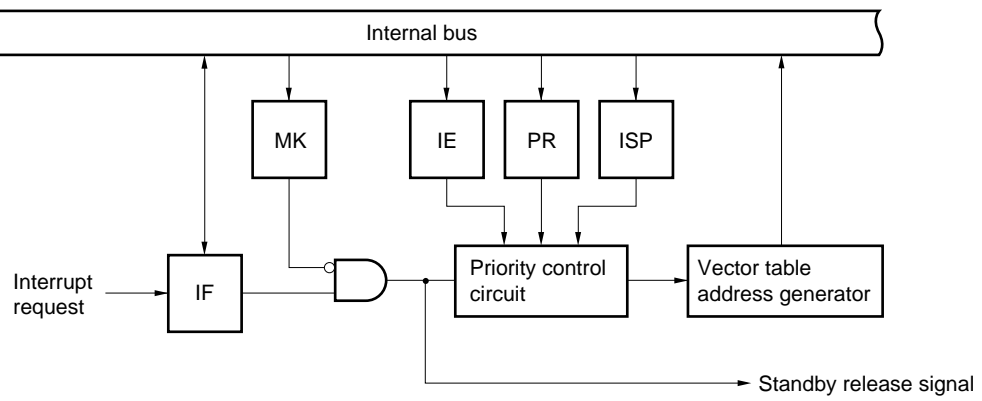

(C) External maskable interrupt (16-bit timer capture input)

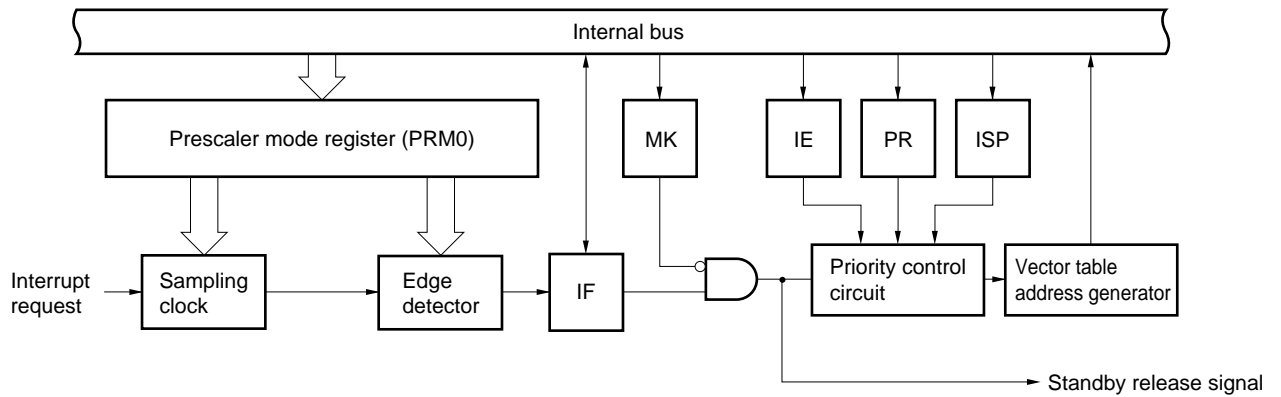
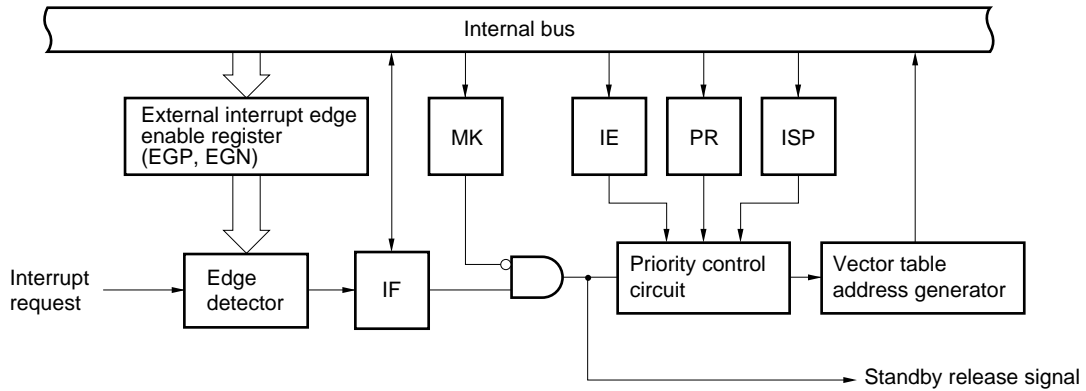
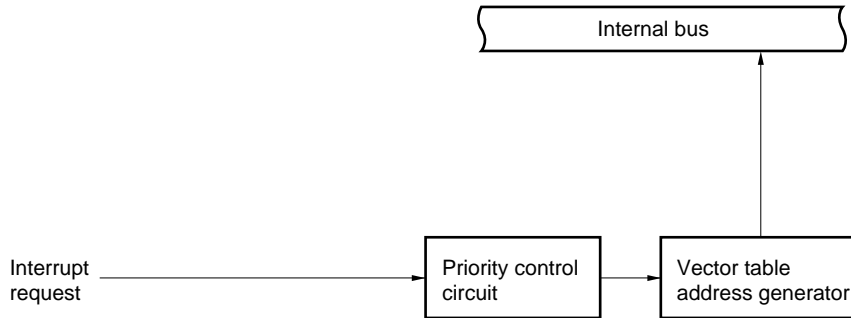

Figure 19-1. Basic Configuration of Interrupt Function (2/2)

(D) External maskable interrupt (except 16-bit timer capture input)



(E) Software interrupt



- IF : Interrupt request flag
- IE : Interrupt enable flag
- ISP : In-service priority flag
- MK : Interrupt mask flag
- PR : Priority specify flag

19.3 Interrupt Function Control Registers

The following 7 types of registers are used to control the interrupt functions.

- Interrupt request flag register (IF0L, IF0H, IF1L)
- Interrupt mask flag register (MK0L, MK0H, MK1L)
- Priority specify flag register (PR0L, PR0H, PR1L)
- External interrupt rising edge enable register (EGP)
- External interrupt falling edge enable register (EGN)
- Prescaler mode register (PRM0)
- Program status word (PSW)

Table 19-2 gives a list of interrupt request flags, interrupt mask flags, and priority specify flags corresponding to interrupt request sources.

Table 19-2. Flags Corresponding to Interrupt Request Sources

Interrupt Source	Interrupt Request Flag		Interrupt Mask Flag		Priority Specify Flag	
	Flag	Register	Flag	Register	Flag	Register
INTWDT	WDTIF	IF0L	WDTMK	MK0L	WDTPR	PR0L
INTAD	ADIF		ADMK			
INTOVF	OVFIF		OVFMK			
INTTM00	TMIF00		TMMK00			
INTTM01	TMIF01		TMMK01			
INTTM02	TMIF02		TMMK02			
INTP0	PIF0		PMK0			
INTP1	PIF1		PMK1			
INTP2	PIF2	IF0H	PMK2	MK0H	PPR2	PR0H
INTCSI	CSIIF		CSIMK			
INTSER	SERIF		SERMK			
INTSR	SRIF		SRMK			
INTST	STIF		STMK			
INTTM1	TMIF1		TMMK1			
INTTM2	TMIF2		TMMK2			
INTTM3	TMIF3		TMMK3			
INTWE	WEIF	IF1L	WEMK	MK1L	WEPR	PR1L
INTWT1	WTIIF		WTIMK			
INTWT	WTIF		WTMK			

Remark The WDTIF, WDTMK, and WDTPR flags are interrupt control flags when the watchdog timer is used as an interval timer.

(1) Interrupt request flag registers (IF0L, IF0H, IF1L)

The interrupt request flags are set to 1 when the corresponding interrupt request is generated or an instruction is executed. They are cleared to 0 when an instruction is executed upon acknowledgment of an interrupt request or upon application of $\overline{\text{RESET}}$ input.

IF0L, IF0H, and IF1L are set with a 1-bit or 8-bit memory manipulation instruction. When IF0L and IF0H are combined to form 16-bit register IF0, they are set with a 16-bit memory manipulation instruction.

$\overline{\text{RESET}}$ input sets these registers to 00H.

Figure 19-2. Interrupt Request Flag Register (IF0L, IF0H, IF1L) Format

Address: FFE0H After Reset: 00H R/W

Symbol	7	6	5	4	3	2	1	0
IF0L	PIF1	PIF0	TMIF02	TMIF01	TMIF00	OVFIF	ADIF	WDTIF

Address: FFE1H After Reset: 00H R/W

Symbol	7	6	5	4	3	2	1	0
IF0H	TMIF3	TMIF2	TMIF1	STIF	SRIF	SERIF	CSIIF	PIF2

Address: FFE2H After Reset: 00H R/W

Symbol	7	6	5	4	3	2	1	0
IF1L	0	0	0	0	0	WTIF	WTIIF	WEIF

XXIFX	Interrupt Request Flag
0	No interrupt request signal is generated
1	Interrupt request signal is generated, interrupt request status

- Cautions**
1. The WDTIF flag is R/W enabled only when the watchdog timer is used as the interval timer. If watchdog timer mode 1 is used, set the WDTIF flag to 0.
 2. Be sure to set 0 to IF1L bits 3 to 7.

(2) Interrupt mask flag registers (MK0L, MK0H, MK1L)

The interrupt mask flags are used to enable/disable the corresponding maskable interrupt service. MK0L, MK0H, and MK1L are set with a 1-bit or 8-bit memory manipulation instruction. When MK0L and MK0H are combined to form a 16-bit register MK0, they are set with a 16-bit memory manipulation instruction. RESET input sets these registers to FFH.

Figure 19-3. Interrupt Mask Flag Register (MK0L, MK0H, MK1L) Format

Address: FFE4H After Reset: FFH R/W

Symbol	7	6	5	4	3	2	1	0
MK0L	PMK1	PMK0	TMMK02	TMMK01	TMMK00	OVFMK	ADMK	WDTMK

Address: FFE5H After Reset: FFH R/W

Symbol	7	6	5	4	3	2	1	0
MK0H	TMMK3	TMMK2	TMMK1	STMK	SRMK	SERMK	CSIMK	PMK2

Address: FFE6H After Reset: FFH R/W

Symbol	7	6	5	4	3	2	1	0
MK1L	1	1	1	1	1	WTMK	WTIMK	WEMK

XXMKX	Interrupt Servicing Control
0	Interrupt servicing enabled
1	Interrupt servicing disabled

- Cautions**
1. If the watchdog timer is used in watchdog timer mode 1, the contents of the WDTMK flag become undefined when read.
 2. Because port 0 pins have an alternate function as external interrupt request input, when the output level is changed by specifying the output mode of the port function, an interrupt request flag is set. Therefore, 1 should be set in the interrupt mask flag before using the output mode.
 3. Be sure to set 1 to MK1L bits 3 to 7.

(3) Priority specify flag registers (PR0L, PR0H, PR1L)

The priority specify flag registers are used to set the corresponding maskable interrupt priority orders. PR0L, PR0H, and PR1L are set with a 1-bit or 8-bit memory manipulation instruction. If PR0L and PR0H are combined to form 16-bit register PR0, they are set with a 16-bit memory manipulation instruction. RESET input sets these registers to FFH.

Figure 19-4. Priority Specify Flag Register (PR0L, PR0H, PR1L) Format

Address: FFE8H After Reset: FFH R/W

Symbol	7	6	5	4	3	2	1	0
PR0L	PPR1	PPR0	TMPR02	TMPR01	TMPR00	OVFPR	ADPR	WDTPR

Address: FFE9H After Reset: FFH R/W

Symbol	7	6	5	4	3	2	1	0
PR0H	TMPR3	TMPR2	TMPR1	STPR	SRPR	SERPR	CSIPR	PPR2

Address: FFEAH After Reset: FFH R/W

Symbol	7	6	5	4	3	2	1	0
PR1L	1	1	1	1	1	WTPR	WTIPR	WEPR

XXPRX	Priority Level Selection
0	High priority level
1	Low priority level

- Cautions**
1. When the watchdog timer is used in the watchdog timer mode 1, set 1 in the WDTPR flag.
 2. Be sure to set 1 to PR1L bits 3 to 7.

(4) External interrupt rising edge enable register (EGP), external interrupt falling edge enable register (EGN)

These registers specify the valid edge for INT_{P0} to INT_{P2}.

EGP and EGN are set with a 1-bit or 8-bit memory manipulation instruction.

$\overline{\text{RESET}}$ input sets these registers to 00H.

Figure 19-5. External Interrupt Rising Edge Enable Register (EGP), External Interrupt Falling Edge Enable Register (EGN) Format

Address: FF48H After Reset: 00H R/W

Symbol	7	6	5	4	3	2	1	0
EGP	0	0	0	0	0	EGP2	EGP1	EGP0

Address: FF49H After Reset: 00H R/W

Symbol	7	6	5	4	3	2	1	0
EGN	0	0	0	0	0	EGN2	EGN1	EGN0

EGP _n	EGN _n	INT _{Pn} Pin Valid Edge Selection (n = 0 to 2)
0	0	Interrupt disable
0	1	Falling edge
1	0	Rising edge
1	1	Both rising and falling edges

(5) Prescaler mode register (PRM0)

This register specifies the valid edge for TI00/P40 to TI02/P42 pins input.

PRM0 is set with an 8-bit memory manipulation instruction.

$\overline{\text{RESET}}$ input sets this register to 00H.

Figure 19-6. Prescaler Mode Register (PRM0) Format

Address: FF70H After Reset: 00H R/W

Symbol	7	6	5	4	3	2	1	0
PRM0	ES21	ES20	ES11	ES10	ES01	ES00	PRM01	PRM00

ES21	ES20	TI02 Valid Edge Selection
0	0	Falling edge
0	1	Rising edge
1	0	Setting prohibited
1	1	Both rising and falling edges

ES11	ES10	TI01 Valid Edge Selection
0	0	Falling edge
0	1	Rising edge
1	0	Setting prohibited
1	1	Both rising and falling edges

ES01	ES00	TI00 Valid Edge Selection
0	0	Falling edge
0	1	Rising edge
1	0	Setting prohibited
1	1	Both rising and falling edges

Caution Set the valid edge of the TI00/P40 to TI02/P42 pins after setting bit 2 of 16-bit timer mode control register 0 (TMC0) to 0 to stop the timer operation.

(6) Program status word (PSW)

The program status word is a register to hold the instruction execution result and the current status for an interrupt request. The IE flag to set maskable interrupt enable/disable and the ISP flag to control multiple processing are mapped.

Besides 8-bit read/write, this register can carry out operations with a bit manipulation instruction and dedicated instructions (EI and DI). When a vectored interrupt request is acknowledged, if the BRK instruction is executed, the contents of PSW are automatically saved into a stack and the IE flag is reset to 0. If a maskable interrupt request is acknowledged, the contents of the priority specify flag of the acknowledged interrupt are transferred to the ISP flag. The PSW contents are also saved into the stack with the PUSH PSW instruction. They are reset from the stack with the RETI, RETB, and POP PSW instructions.

$\overline{\text{RESET}}$ input sets PSW to 02H.

Figure 19-7. Program Status Word Format

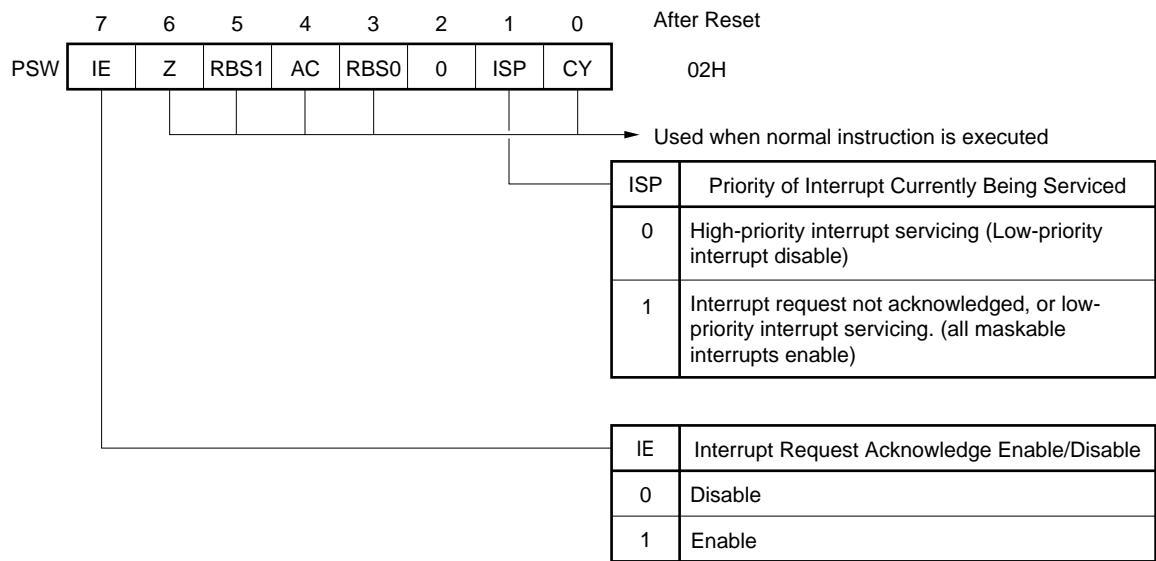

19.4 Interrupt Servicing Operations

19.4.1 Non-maskable interrupt request acknowledge operation

A non-maskable interrupt request is unconditionally acknowledged even if in an interrupt acknowledge disable state. It does not undergo interrupt priority control and has highest priority over all other interrupts.

If a non-maskable interrupt request is acknowledged, the contents are saved into the stacks in the order of PSW, then PC, the IE flag and ISP flag are reset (to 0), and the contents of the vector table are loaded into PC and branched.

A new non-maskable interrupt request generated during execution of a non-maskable interrupt servicing program is acknowledged after the current execution of the non-maskable interrupt servicing program is terminated (following RETI instruction execution) and one main routine instruction is executed. However, if a new non-maskable interrupt request is generated twice or more during non-maskable interrupt servicing program execution, only one non-maskable interrupt request is acknowledged after termination of the non-maskable interrupt servicing program execution. Figures 19-8, 19-9, and 19-10 show the flowchart of the non-maskable interrupt request generation through acknowledge, acknowledge timing of non-maskable interrupt request, and acknowledge operation at multiple non-maskable interrupt request generation, respectively.

Figure 19-8. Non-Maskable Interrupt Request Generation to Acknowledge Flowchart

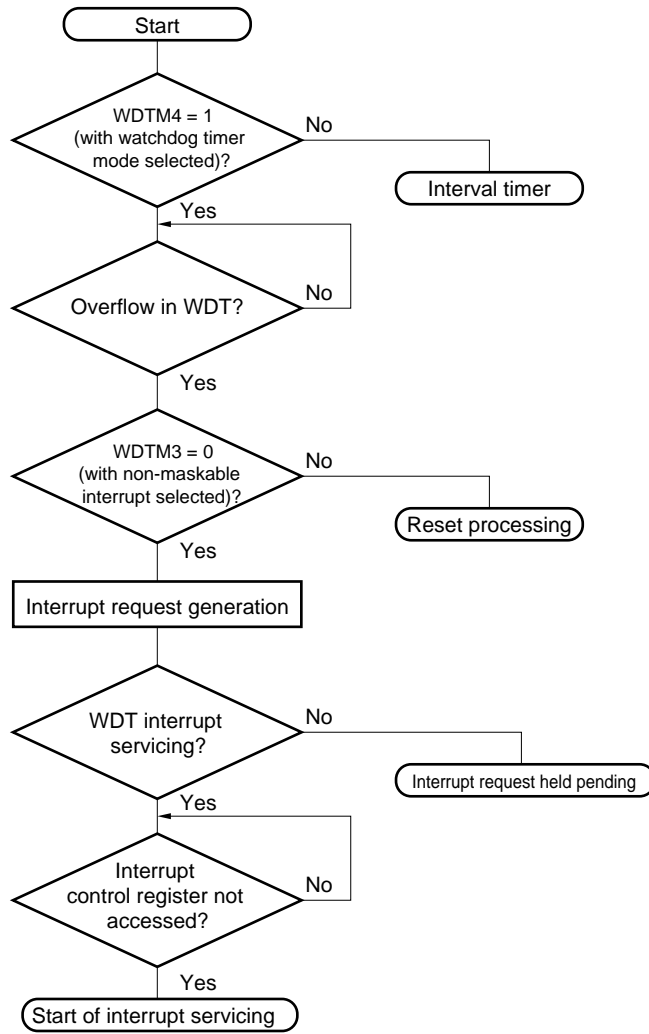

WDTM: Watchdog timer mode register
 WDT : Watchdog timer

Figure 19-9. Non-Maskable Interrupt Request Acknowledge Timing

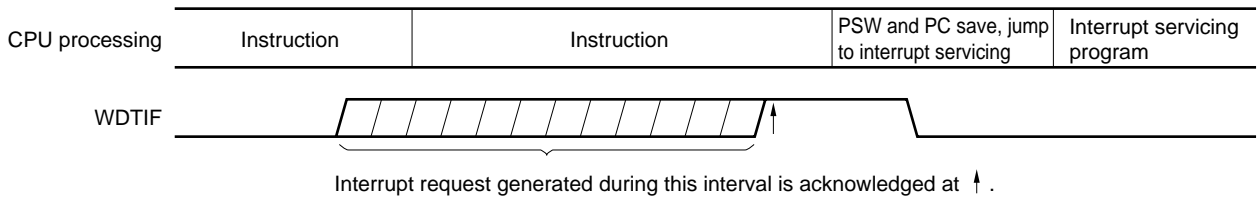

WDTIF: Watchdog timer interrupt request flag

Figure 19-10. Non-Maskable Interrupt Request Acknowledge Operation

(a) If a non-maskable interrupt request is generated during non-maskable interrupt servicing program execution

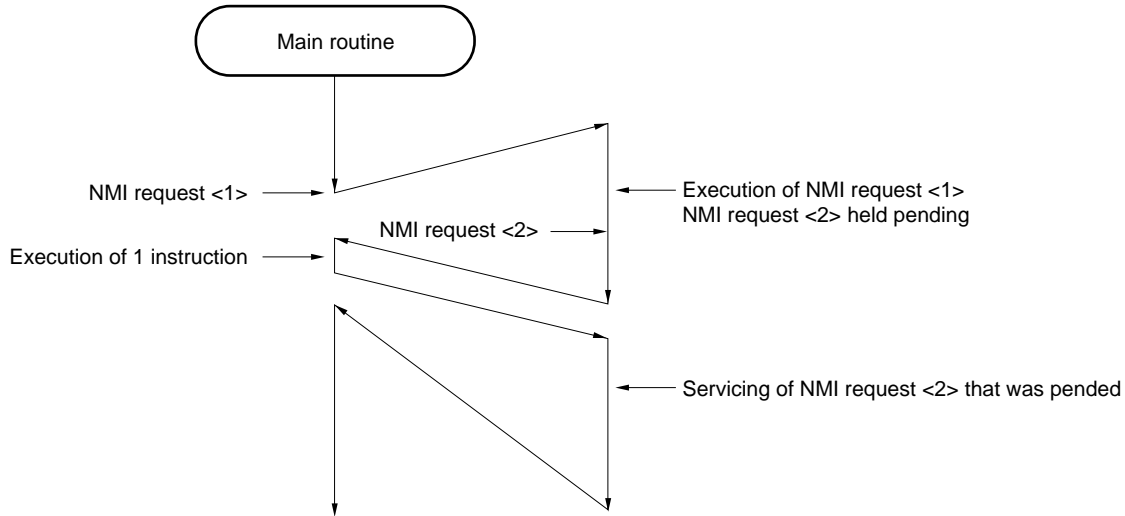

(b) If two non-maskable interrupt requests are generated during non-maskable interrupt servicing program execution

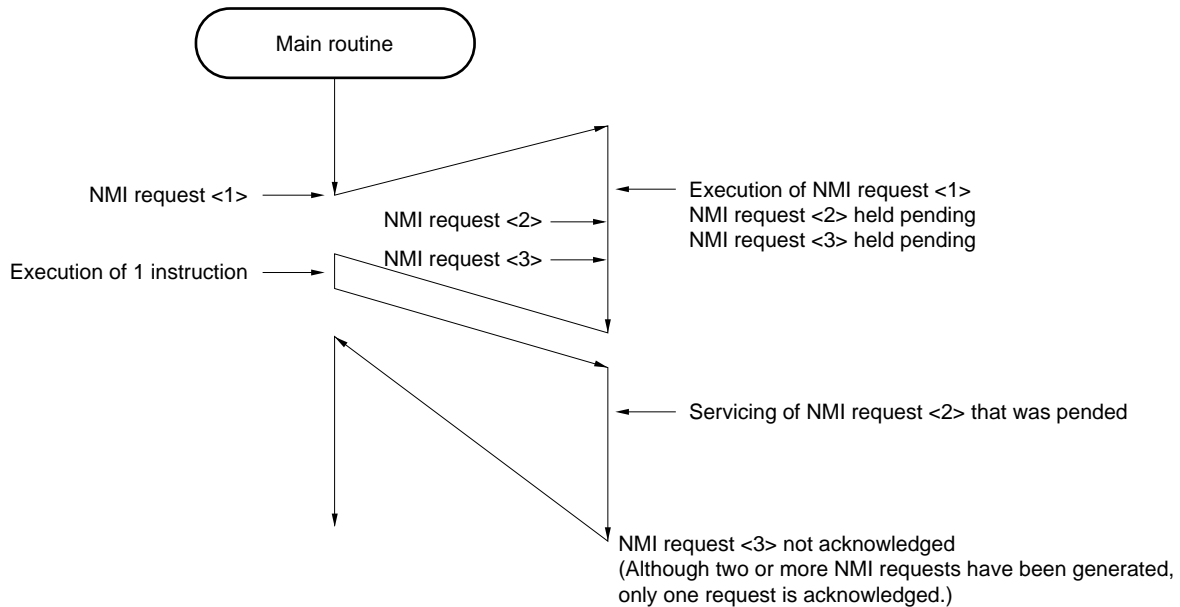

19.4.2 Maskable interrupt request acknowledge operation

A maskable interrupt request becomes acknowledgeable when an interrupt request flag is set to 1 and the mask (MK) flag corresponding to that interrupt is cleared to 0. A vectored interrupt request is acknowledged if in the interrupt enable state (when IE flag is set to 1). However, a low-priority interrupt request is not acknowledged during servicing of a higher priority interrupt request (when the ISP flag is reset to 0).

The times from generation of a maskable interrupt request until interrupt servicing is performed are listed in Table 19-3 below.

For the interrupt request acknowledge timing, see the Figures 19-12 and 19-13.

Table 19-3. Times from Generation of Maskable Interrupt Request until Servicing

	Minimum Time	Maximum Time ^{Note}
When $\times\times PR = 0$	7 clocks	32 clocks
When $\times\times PR = 1$	8 clocks	33 clocks

Note If an interrupt request is generated just before a divide instruction, the wait time becomes longer.

Remark 1 clock: $1/f_{CPU}$ (f_{CPU} : CPU clock)

If two or more maskable interrupt requests are generated simultaneously, the request with a higher priority level specified in the priority specify flag is acknowledged first. If two or more interrupts requests have the same priority level, the request with the highest default priority is acknowledged first.

An interrupt request that is held pending is acknowledged when it becomes acknowledgeable.

Figure 19-11 shows the interrupt request acknowledge algorithm.

If a maskable interrupt request is acknowledged, the contents are saved into the stacks in the order of program status word (PSW), then program counter (PC), the IE flag is reset (to 0), and the contents of the priority specify flag corresponding to the acknowledged interrupt are transferred to the ISP flag. Further, the vector table data determined for each interrupt request is loaded into PC and branched.

Return from an interrupt is possible with the RETI instruction.

Figure 19-11. Interrupt Request Acknowledge Processing Algorithm

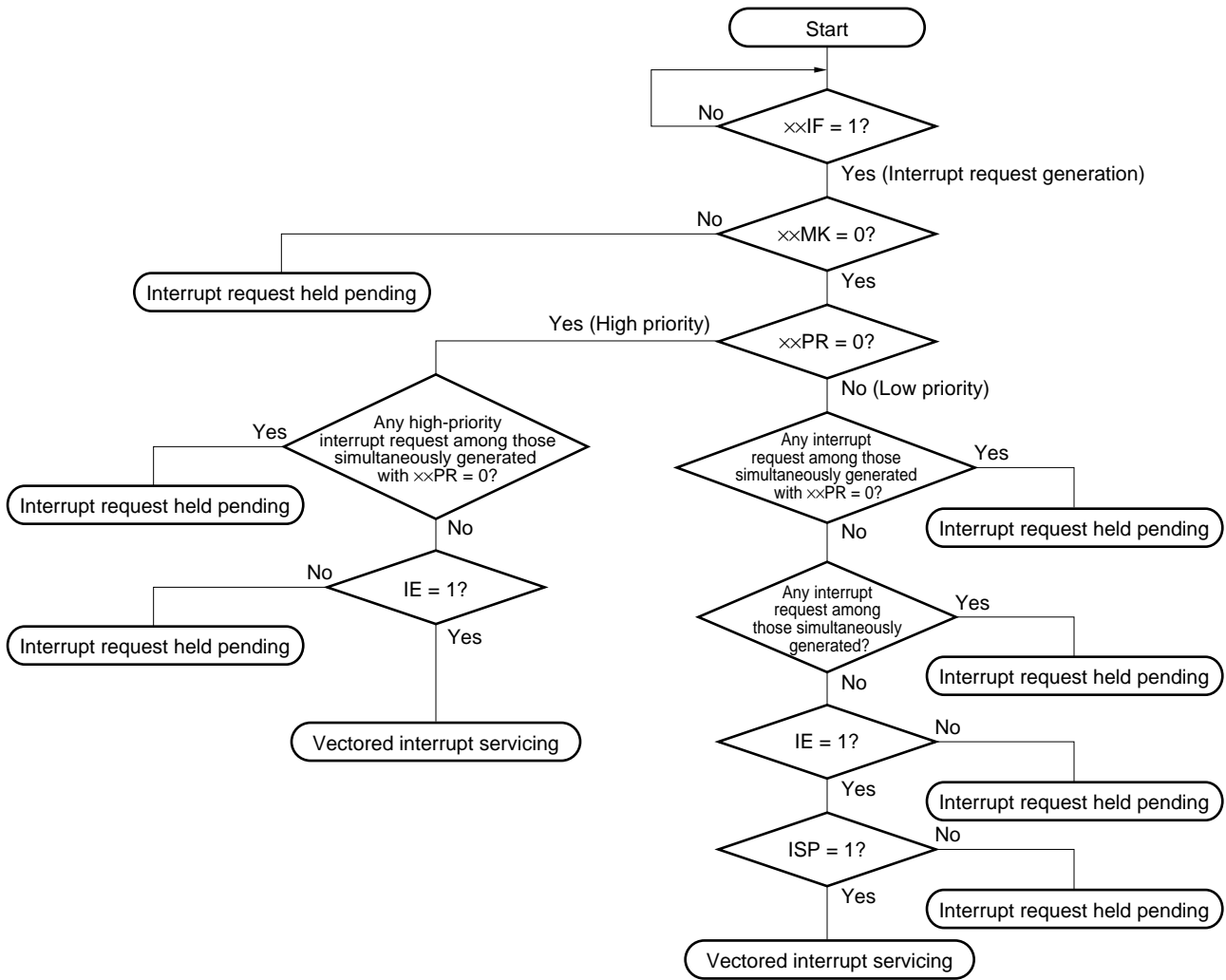

xxIF : Interrupt request flag

xxMK : Interrupt mask flag

xxPR : Priority specify flag

IE : Flag that controls acknowledge of maskable interrupt request (1 = Enable, 0 = Disable)

ISP : Flag that indicates the priority level of the interrupt currently being serviced (0 = High-priority interrupt servicing, 1 = No interrupt request acknowledged, or low-priority interrupt servicing)

Figure 19-12. Interrupt Request Acknowledge Timing (Minimum Time)

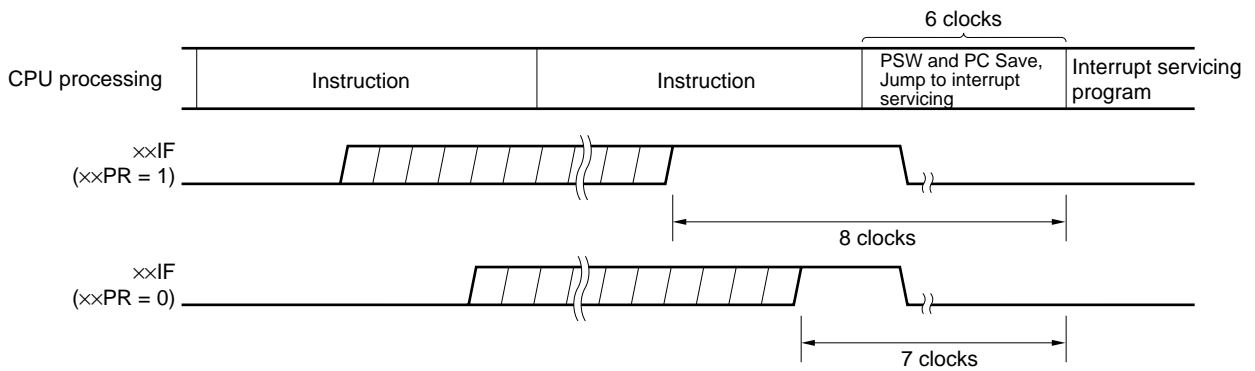

Remark 1 clock: $1/f_{CPU}$ (f_{CPU} : CPU clock)

Figure 19-13. Interrupt Request Acknowledge Timing (Maximum Time)

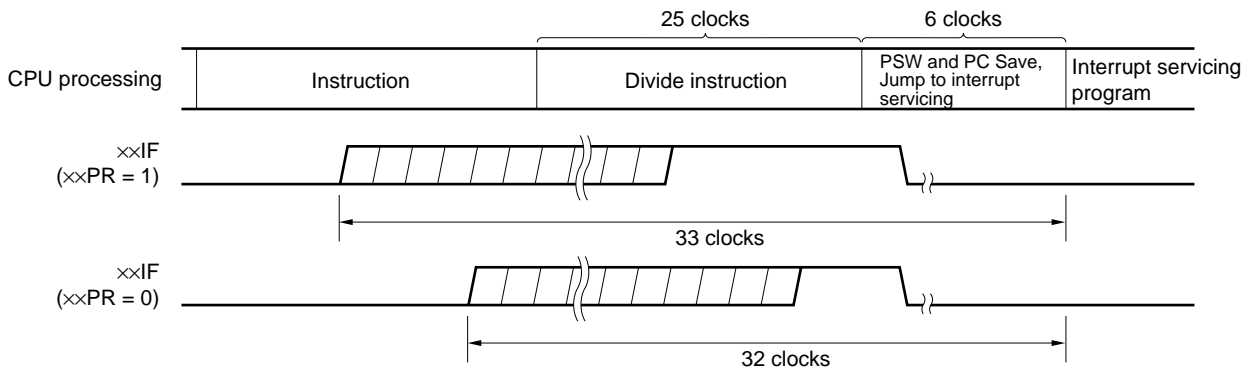

Remark 1 clock: $1/f_{CPU}$ (f_{CPU} : CPU clock)

19.4.3 Software interrupt request acknowledge operation

A software interrupt acknowledge is acknowledged by BRK instruction execution. Software interrupts cannot be disabled.

If a software interrupt request is acknowledged, the contents are saved into the stacks in the order of the program status word (PSW), then program counter (PC), the IE flag is reset (to 0), and the contents of the vector table (003EH, 003FH) are loaded into PC and branched.

Return from a software interrupt is possible with the RETB instruction.

Caution Do not use the RETI instruction for returning from the software interrupt.

19.4.4 Multiple interrupt servicing

Multiple interrupts occur when another interrupt request is acknowledged during execution of an interrupt.

Multiple interrupts do not occur unless the interrupt request acknowledge enable state is selected (IE = 1) (except non-maskable interrupts). Also, when an interrupt request is received, interrupt requests acknowledge becomes disabled (IE = 0). Therefore, to enable multiple interrupts, it is necessary to set (to 1) the IE flag with the EI instruction during interrupt servicing to enable interrupt acknowledge.

Moreover, even if interrupts are enabled, multiple interrupts may not be enabled, this being subject to interrupt priority control. Two types of priority control are available: default priority control and programmable priority control. Programmable priority control is used for multiple interrupts.

In the interrupt enable state, if an interrupt request with a priority equal to or higher than that of the interrupt currently being serviced is generated, it is acknowledged for multiple interrupt servicing. If an interrupt with a priority lower than that of the interrupt currently being serviced is generated during interrupt servicing, it is not acknowledged for multiple interrupt servicing. Interrupt requests that are not enabled because of the interrupt disable state or they have a lower priority are held pending. When servicing of the current interrupt ends, the pended interrupt request is acknowledged following execution of one main processing instruction execution.

Multiple interrupt servicing is not possible during non-maskable interrupt servicing.

Table 19-4 shows interrupt requests enabled for multiple interrupt servicing, and Figure 19-14 shows multiple interrupt examples.

Table 19-4. Interrupt Request Enabled for Multiple Interrupt during Interrupt Servicing

Multiple Interrupt Request Interrupt being Serviced		Non-Maskable Interrupt Request	Maskable Interrupt Request			
			PR = 0		PR = 1	
			IE = 1	IE = 0	IE = 1	IE = 0
Non-maskable interrupt		×	×	×	×	×
Maskable interrupt	ISP = 0	○	○	×	×	×
	ISP = 1	○	○	×	○	×
Software interrupt		○	○	×	○	×

- Remarks**
1. ○ : Multiple interrupt enable
 2. × : Multiple interrupt disable
 3. ISP and IE are flags contained in PSW.
 ISP = 0 : An interrupt with higher priority is being serviced.
 ISP = 1 : No interrupt request has been acknowledged, or an interrupt with a lower priority is being serviced.
 IE = 0 : Interrupt request acknowledge is disabled.
 IE = 1 : Interrupt request acknowledge is enabled.
 4. PR is a flag contained in PROL, PROH, and PR1L.
 PR = 0 : Higher priority level
 PR = 1 : Lower priority level

Figure 19-14. Multiple Interrupt Examples (1/2)

Example 1. Multiple interrupts occur twice

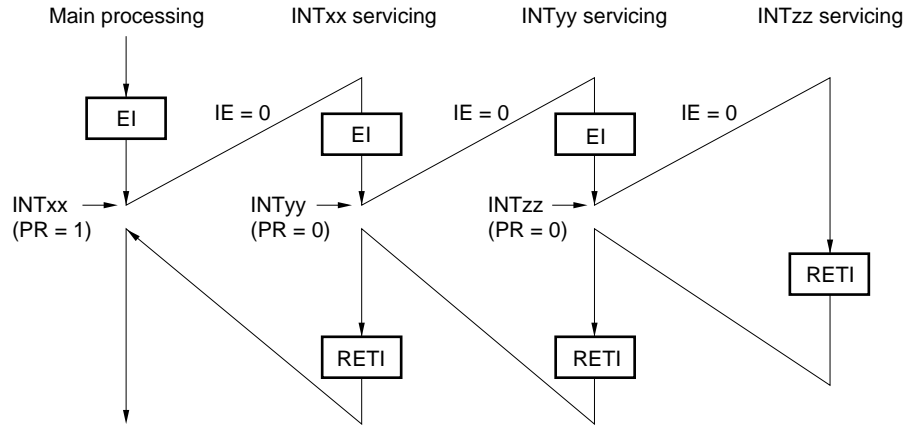

During servicing of interrupt INTxx, two interrupt requests, INTyy and INTzz, are acknowledged, and multiple interrupt servicing takes place. Before each interrupt request is acknowledged, the EI instruction must always be issued to enable interrupt request acknowledge.

Example 2. Multiple interrupt servicing does not occur due to priority control

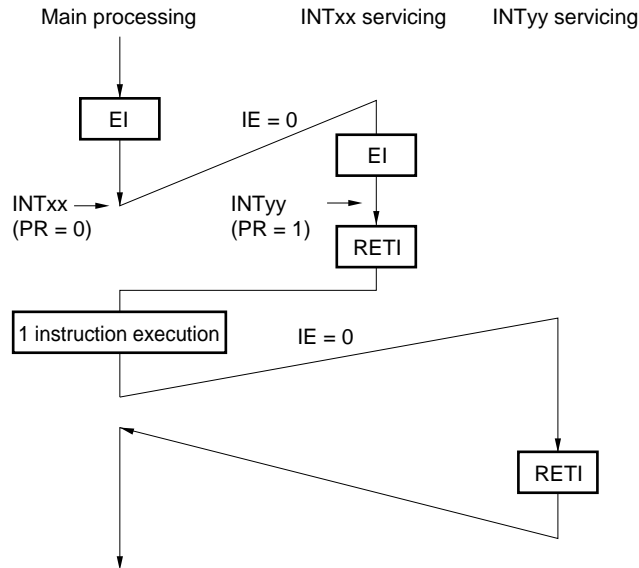

Interrupt request INTyy issued during servicing of interrupt INTxx is not acknowledged because its priority is lower than that of INTxx, and multiple interrupt servicing does not take place. The INTyy interrupt request is held pending, and is acknowledged following execution of one main processing instruction.

- PR = 0 : Higher priority level
- PR = 1 : Lower priority level
- IE = 0 : Interrupt request acknowledge disable

Figure 19-14. Multiple Interrupt Examples (2/2)

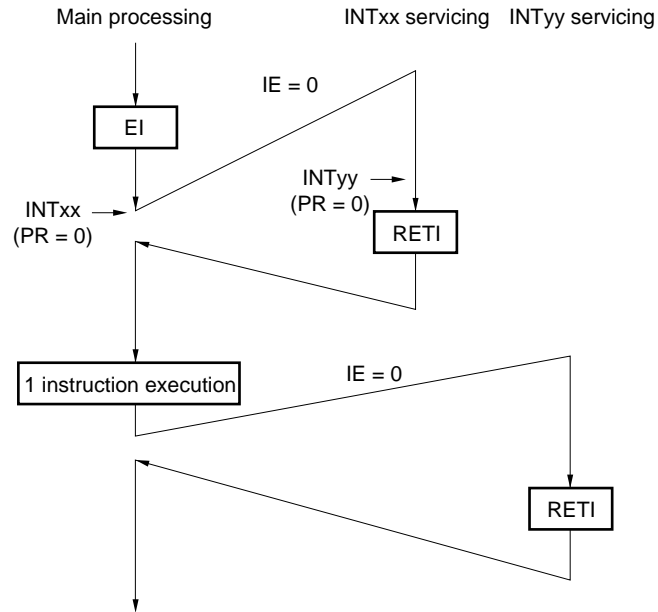
Example 3. Multiple interrupt servicing does not occur because interrupt is not enabled

Interrupt is not enabled during servicing of interrupt INTxx (EI instruction is not issued), therefore, interrupt request INTyy is not acknowledged and multiple interrupt servicing does not take place. The INTyy interrupt request is held pending, and is acknowledged following execution of one main processing instruction.

PR = 0 : Higher priority level

IE = 0 : Interrupt request acknowledge disable

19.4.5 Interrupt request hold

There are instructions where, even if an interrupt request is issued for them while another instruction is executed, request acknowledge is held pending until the end of execution of the next instruction. These instructions (interrupt request hold instructions) are listed below.

- MOV PSW, #byte
- MOV A, PSW
- MOV PSW, A
- MOV1 PSW.bit, CY
- MOV1 CY, PSW.bit
- AND1 CY, PSW.bit
- OR1 CY, PSW.bit
- XOR1 CY, PSW.bit
- SET1 PSW.bit
- CLR1 PSW.bit
- RETB
- RETI
- PUSH PSW
- POP PSW
- BT PSW.bit, \$addr16
- BF PSW.bit, \$addr16
- BTCLR PSW.bit, \$addr16
- EI
- DI
- Manipulate instructions for the IF0L, IF0H, IF1L, MK0L, MK0H, MK1L, PR0L, PR0H, PR1L, EGP, and EGN registers

Caution The BRK instruction is not one of the above-listed interrupt request hold instruction. However, the software interrupt activated by executing the BRK instruction causes the IE flag to be cleared. Therefore, even if a maskable interrupt request is generated during execution of the BRK instruction, the interrupt request is not acknowledged. However, a non-maskable interrupt request is acknowledged.

The timing with which interrupt requests are held pending is shown in Figure 19-15.

Figure 19-15. Interrupt Request Hold

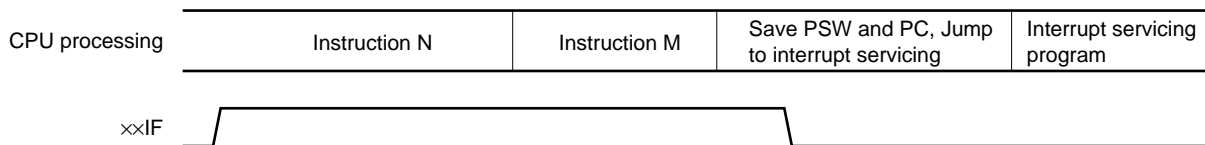

- Remarks**
1. Instruction N: Interrupt request hold instruction
 2. Instruction M: Instruction other than interrupt request hold instruction
 3. The $\times\times$ PR (priority level) values do not affect the operation of $\times\times$ IF (interrupt request).

[MEMO]

CHAPTER 20 STANDBY FUNCTION

20.1 Standby Function and Configuration

20.1.1 Standby function

The standby function is designed to decrease power consumption of the system. The following two modes are available.

(1) HALT mode

Halt instruction execution sets the HALT mode. The HALT mode is intended to stop the CPU operation clock. The system clock oscillator continues oscillating. In this mode, current consumption is not decreased as much as in the STOP mode. However, the HALT mode is effective to restart operation immediately upon interrupt request and to carry out intermittent operations such as watch operation.

(2) STOP mode

Stop instruction execution sets the STOP mode. In the STOP mode, the main system clock oscillator stops, stopping the whole system, thereby considerably reducing the CPU current consumption.

Data memory low-voltage hold (down to $V_{DD} = 2.0\text{ V}$) is possible. Thus, the STOP mode is effective to hold data memory contents with ultra-low current consumption.

Because this mode can be cleared upon interrupt request, it enables intermittent operations to be carried out. However, because a wait time is required to secure an oscillation stabilization time after the STOP mode is cleared, select the HALT mode if it is necessary to start processing immediately upon interrupt request.

In either of these two modes, all the contents of registers, flags and data memory just before the standby mode is set are held. The input/output port output latch and output buffer status are also held.

- Cautions**
1. When operation is transferred to the STOP mode, be sure to stop the peripheral hardware operation and execute the STOP instruction.
 2. The following sequence is recommended for power consumption reduction of the A/D converter when the standby function is used: First clear bit 7 (ADCS1) of the A/D converter mode register (ADM1) to 0 to stop the A/D conversion operation, and then execute the HALT or STOP instruction.

20.1.2 Standby function control register

The wait time after the STOP mode is cleared upon interrupt request is controlled with the oscillation stabilization time select register (OSTS).

OSTS is set with an 8-bit memory manipulation instruction.

$\overline{\text{RESET}}$ input sets OSTS to 04H.

Figure 20-1. Oscillation Stabilization Time Select Register (OSTS) Format

Address: FFFAH After Reset: 04H R/W

Symbol	7	6	5	4	3	2	1	0
OSTS	0	0	0	0	0	OSTS2	OSTS1	OSTS0

OSTS2	OSTS1	OSTS0	Selection of Oscillation Stabilization Time
0	0	0	$2^{12}/f_x$ (488 μs)
0	0	1	$2^{14}/f_x$ (1.95 ms)
0	1	0	$2^{15}/f_x$ (3.91 ms)
0	1	1	$2^{16}/f_x$ (7.81 ms)
1	0	0	$2^{17}/f_x$ (15.6 ms)
Other than above			Setting prohibited

Caution The wait time after the STOP mode is cleared does not include the time (see “a” in the illustration below) from STOP mode clear to clock oscillation start, regardless of clearance by $\overline{\text{RESET}}$ input or by interrupt request generation.

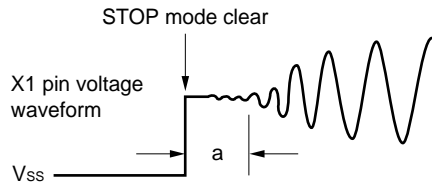

- Remarks**
1. f_x : Main system clock oscillation frequency
 2. Values in parentheses apply to operation with $f_x = 8.38$ MHz.

20.2 Standby Function Operations

20.2.1 HALT mode

(1) HALT mode setting and operating status

The HALT mode is set by executing the HALT instruction.

The operating status in the HALT mode is described below.

Table 20-1. HALT Mode Operating Status

Item	HALT Mode Setting	During HALT Instruction Execution Using Main System Clock
Clock generator		Main system clock can be oscillated. Clock supply to CPU stops.
CPU		Operation stops.
Port (Output latch)		Status before HALT mode setting is held.
16-bit timer		Operable
8-bit timer		
Watch timer		
Watchdog timer		
A/D converter		Operation stops.
Serial interface		Operable
LCD controller/driver		
External interrupt		
Sound generator		
Meter controller/driver		

★

(2) HALT mode clear

The HALT mode can be cleared with the following three types of sources.

(a) Clear upon unmasked interrupt request

An unmasked interrupt request is used to clear the HALT mode. If interrupt acknowledge is enabled, vectored interrupt service is carried out. If interrupt acknowledge is disabled, the next address instruction is executed.

Figure 20-2. HALT Mode Clear upon Interrupt Generation

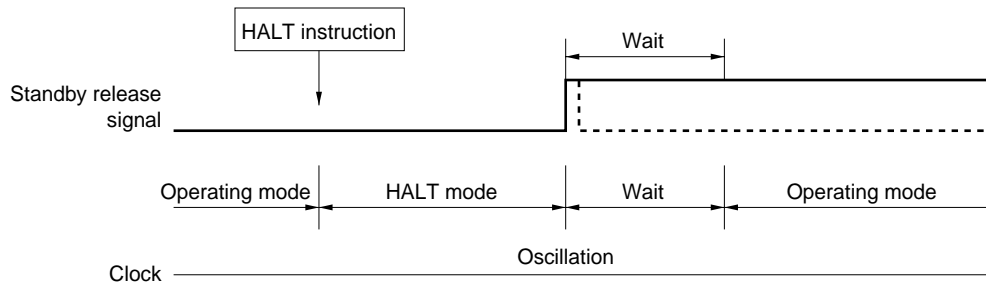

Remarks 1. The broken line indicates the case when the interrupt request which has cleared the standby mode is acknowledged.

2. Wait times are as follows:

- When vectored interrupt service is carried out : 8 to 9 clocks
- When vectored interrupt service is not carried out : 2 to 3 clocks

(b) Clear upon non-maskable interrupt request

The HALT mode is cleared and vectored interrupt service is carried out whether interrupt acknowledge is enabled or disabled.

(c) Clear upon $\overline{\text{RESET}}$ input

As in the case with normal reset operation, a program is executed after branch to the reset vector address.

Figure 20-3. HALT Mode Clear upon $\overline{\text{RESET}}$ Input

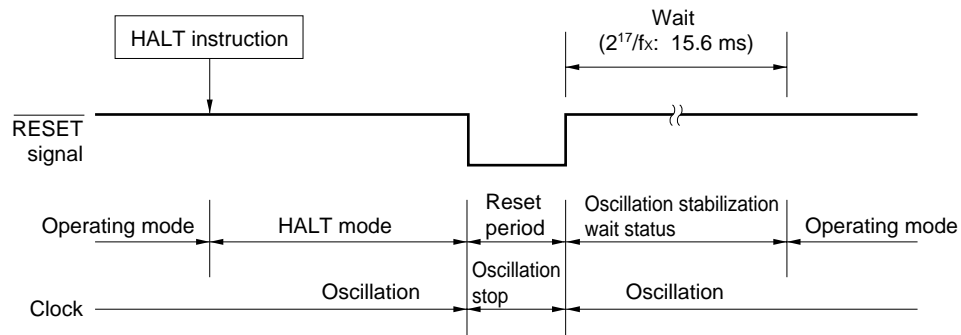

- Remarks**
1. f_x : Main system clock oscillation frequency
 2. Values in parentheses apply to operation with $f_x = 8.38$ MHz.

Table 20-2. Operation after HALT Mode Clear

Clear Source	MK $\times\times$	PR $\times\times$	IE	ISP	Operation
Maskable interrupt request	0	0	0	×	Next address instruction execution
	0	0	1	×	Interrupt service execution
	0	1	0	1	Next address instruction execution
	0	1	×	0	Interrupt service execution
	0	1	1	1	
	1	×	×	×	HALT mode hold
Non-maskable interrupt request	—	—	×	×	Interrupt service execution
$\overline{\text{RESET}}$ input	—	—	×	×	Reset processing

×: don't care

20.2.2 STOP mode

(1) STOP mode setting and operating status

The STOP mode is set by executing the STOP instruction.

- Cautions**
1. When the STOP mode is set, the X2 pin is internally connected to V_{DD} via a pull-up resistor to minimize the leakage current at the crystal oscillator. Thus, do not use the STOP mode in a system where an external clock is used for the main system clock.
 2. Because the interrupt request signal is used to clear the standby mode, if there is an interrupt source with the interrupt request flag set and the interrupt mask flag reset, the standby mode is immediately cleared if set. Thus, the STOP mode is reset to the HALT mode immediately after execution of the STOP instruction. After the wait set using the oscillation stabilization time select register (OSTS), the operating mode is set.

The operating status in the STOP mode is described below.

Table 20-3. STOP Mode Operating Status

STOP Mode Setting		During STOP Instruction Execution Using Main System Clock
Item		
Clock generator		Only main system clock oscillation is stopped.
CPU		Operation stops.
Port (Output latch)		Status before STOP mode setting is held.
16-bit timer		Operation stops.
8-bit timer		Operable only when TIO2 and TIO3 are selected as count clock.
Watch timer		Operation stops.
Watchdog timer		Operation stops.
A/D converter		Operation stops.
Serial interface	Other than UART	Operable only when externally supplied input clock is specified as the serial clock.
	UART	Operation stops.
LCD controller/driver		Operation stops.
External interrupt		Operable
Sound generator		Operation stops.
Meter controller/driver		Operation stops.

(2) STOP mode clear

The STOP mode can be cleared with the following two types of sources.

(a) Clear upon unmasked interrupt request

An unmasked interrupt request is used to clear the STOP mode. If interrupt acknowledge is enabled after the lapse of oscillation stabilization time, vectored interrupt service is carried out. If interrupt acknowledge is disabled, the next address instruction is executed.

Figure 20-4. STOP Mode Clear upon Interrupt Generation

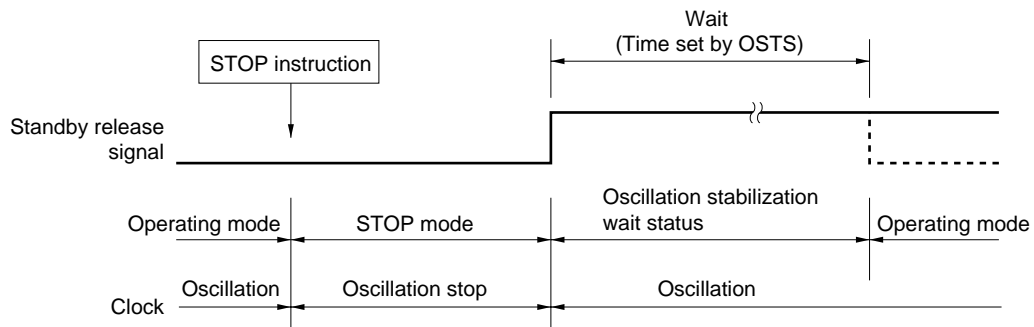

Remark The broken line indicates the case when the interrupt request which has cleared the standby mode is acknowledged.

(b) Clear upon $\overline{\text{RESET}}$ input

The STOP mode is cleared and after the lapse of oscillation stabilization time, reset operation is carried out.

Figure 20-5. STOP Mode Clear upon $\overline{\text{RESET}}$ Input

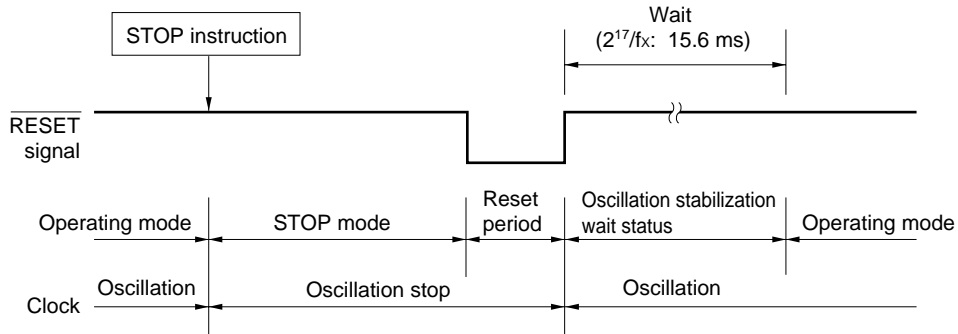

- Remarks**
1. f_x: Main system clock oscillation frequency
 2. Values in parentheses apply to operation with f_x = 8.38 MHz.

Table 20-4. Operation after STOP Mode Clear

Clear Source	MK _{xx}	PR _{xx}	IE	ISP	Operation
Maskable interrupt request	0	0	0	×	Next address instruction execution
	0	0	1	×	Interrupt service execution
	0	1	0	1	Next address instruction execution
	0	1	×	0	
	0	1	1	1	Interrupt service execution
	1	×	×	×	STOP mode hold
$\overline{\text{RESET}}$ input	—	—	×	×	Reset processing

×: don't care

CHAPTER 21 RESET FUNCTION

21.1 Reset Function

The following two operations are available to generate the reset signal.

- (1) External reset input with $\overline{\text{RESET}}$ pin
- (2) Internal reset by watchdog timer overrun time detection

External reset and internal reset have no functional differences. In both cases, program execution starts at the address at 0000H and 0001H by $\overline{\text{RESET}}$ input.

When a low level is input to the $\overline{\text{RESET}}$ pin or the watchdog timer overflows, a reset is applied and each hardware is set to the status shown in Table 21-1. Each pin has high impedance during reset input or during oscillation stabilization time just after reset clear.

When a high level is input to the $\overline{\text{RESET}}$ pin, the reset is cleared and program execution starts after the lapse of oscillation stabilization time ($2^{17}/f_x$). The reset applied by watchdog timer overflow is automatically cleared after a reset and program execution starts after the lapse of oscillation stabilization time ($2^{17}/f_x$) (see Figures 21-2 to 21-4).

- Cautions**
1. For an external reset, input a low level for 10 μs or more to the $\overline{\text{RESET}}$ pin.
 2. During reset input, main system clock oscillation remains stopped but subsystem clock oscillation continues.
 3. When the STOP mode is cleared by reset, the STOP mode contents are held during reset input. However, the port pin becomes high-impedance.

Figure 21-1. Reset Function Block Diagram

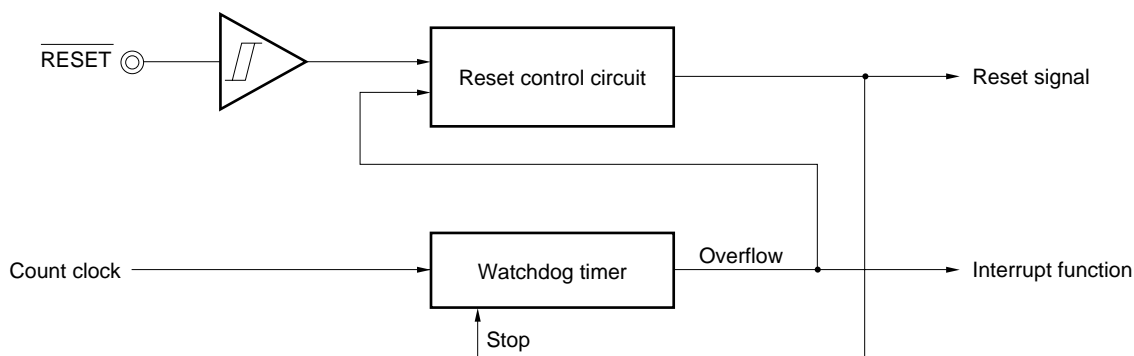

Figure 21-2. Timing of Reset by $\overline{\text{RESET}}$ Input

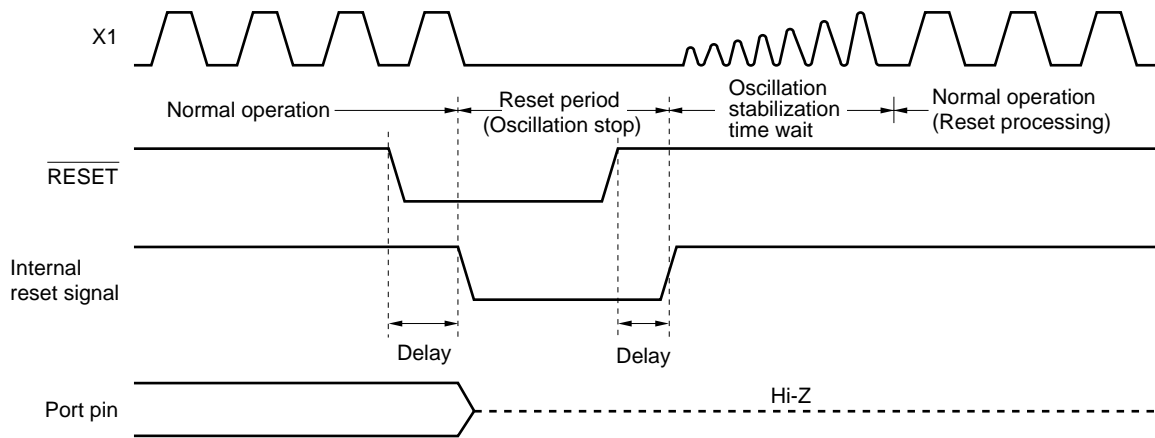

Figure 21-3. Timing of Reset due to Watchdog Timer Overflow

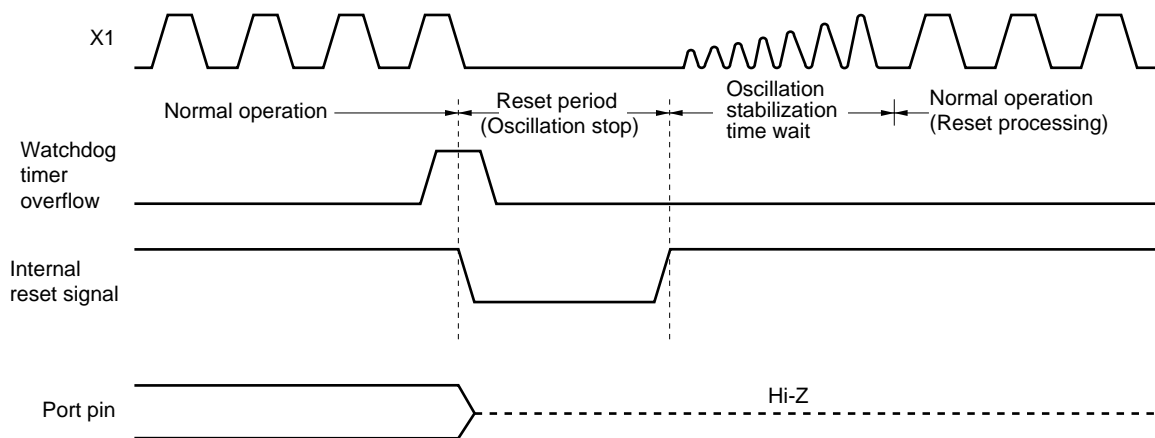

Figure 21-4. Timing of Reset in STOP Mode by $\overline{\text{RESET}}$ Input

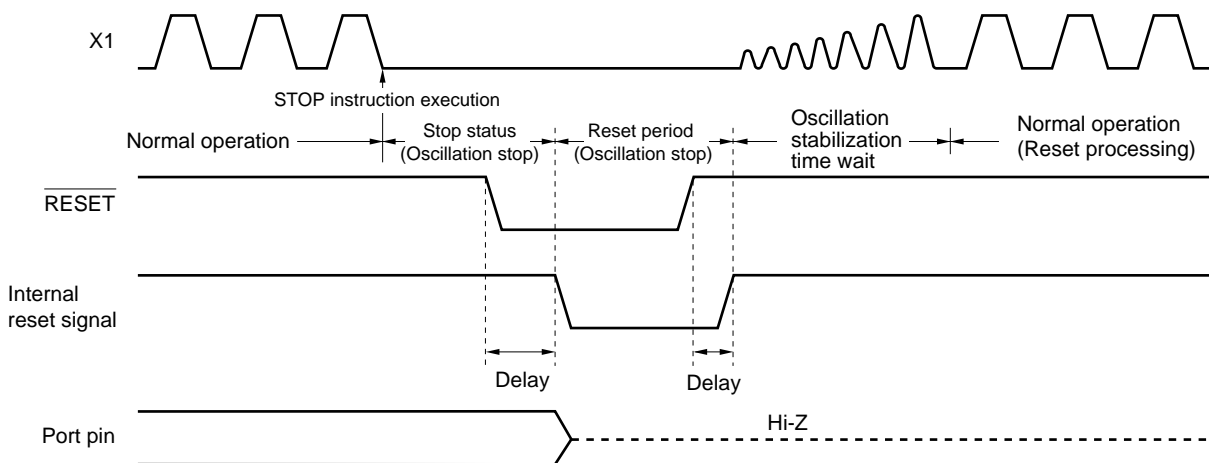

Table 21-1. Hardware Status after Reset (1/2)

Hardware		Status After Reset
Program counter (PC) Note 1		Contents of reset vector table (0000H, 0001H) are set.
Stack pointer (SP)		Undefined
Program status word (PSW)		02H
RAM	Data memory	Undefined Note 2
	General register	Undefined Note 2
Port (Output latch)		00H
Port mode registers (PM0 to PM6, PM8, PM9)		FFH
Pull-up resistor option register (PU0)		00H
Processor clock control register (PCC)		04H
Memory size switching register (IMS)		CFH
Oscillation stabilization time select register (OSTS)		04H
Oscillator mode register (OSCM) Note 3		00H
16-bit timer TM0	Timer register (TM0)	00H
	Capture registers (CR00 to CR02)	00H
	Prescaler mode register (PRM0)	00H
	Mode control register (TMC0)	00H
	Capture pulse control register (CRC0)	00H

★

- Notes**
1. During reset input or oscillation stabilization time wait, only the PC contents among the hardware status become undefined. All other hardware statuses remain unchanged after reset.
 2. The post-reset status is held in the standby mode.
 3. For μ PD780973(A) only.

Table 21-1. Hardware Status after Reset (2/2)

	Hardware	Status After Reset
8-bit timer TM1 to TM3	Timer counters (TM1 to TM3)	00H
	Compare registers (CR1 to CR3)	00H
	Clock select registers (TCL1 to TCL3)	00H
	Mode control registers (TMC1 to TMC3)	04H
Watch timer	Mode control register (WTM)	00H
Watchdog timer	Clock select register (WDCS)	00H
	Mode register (WDTM)	00H
A/D converter	Conversion result register (ADCR1)	00H
	Mode register (ADM1)	00H
	Analog input channel specification register (ADS1)	00H
	Power-fail compare mode register (PFM)	00H
	Power-fail compare threshold value register (PFT)	00H
Serial interface UART	Asynchronous serial interface mode register (ASIM)	00H
	Asynchronous serial interface status register (ASIS)	00H
	Baud rate generator control register (BRGC)	00H
	Transmit shift register (TXS)	FFH
	Receive buffer register (RXB)	
Serial interface SIO3	Shift register (SIO)	00H
	Mode register (CSIM)	00H
LCD controller/driver	Display mode register (LCDM)	00H
	Display control register (LCDC)	00H
EEPROM	Write control register (EEWC)	00H
Sound generator	Control register (SGCR)	00H
	Buzzer control register (SGBR)	00H
	Amplitude register (SGAM)	00H
Meter controller/driver	Compare registers (MCMP10, MCMP11, MCMP20, MCMP21, MCMP30, MCMP31, MCMP40, MCMP41)	00H
	Timer mode control register (MCNTC)	00H
	Port mode control register (PMC)	00H
	Compare control registers (MCMPC1 to MCMPC3)	00H
Interrupt	Request flag registers (IF0L, IF0H, IF1L)	00H
	Mask flag registers (MK0L, MK0H, MK1L)	FFH
	Priority specify flag registers (PR0L, PR0H, PR1L)	FFH
	External interrupt rising edge enable register (EGP)	00H
	External interrupt falling edge enable register (EGN)	00H

CHAPTER 22 μ PD78F0974

The μ PD78F0974 replace the internal ROM of the μ PD780973(A) with flash memory to which a program can be written, deleted and overwritten while mounted on a board. Table 22-1 lists the differences between the μ PD78F0974 and the μ PD780973(A).

Table 22-1. Differences between μ PD78F0974 and μ PD780973(A)

Item	μ PD78F0974	μ PD780973(A)
ROM type	Flash memory	Mask ROM
Internal ROM capacity	32 Kbytes	24 Kbytes
Internal high-speed RAM capacity	1024 bytes	768 bytes
Change of internal ROM and internal high-speed RAM capacity using memory size switching register	Possible Note	Not provided
IC pin	None	Available
V _{PP} pin	Available	None
Electrical specifications	See data sheet of each product.	
Quality grade	Standard	Special

★ **Note** Although the initial value is CFH, set the following values.

IMS Setting Value	Flash Memory	Internal High-speed RAM	Remarks
06H	24 Kbytes	768 bytes	When using the same memory map as that of μ PD780973(A)
C8H	32 Kbytes	1024 bytes	When using the maximum value

Caution There are differences in noise immunity and noise radiation between the flash memory and mask ROM versions. When pre-producing an application set with the flash memory version and then mass-producing it with the mask ROM version, be sure to conduct sufficient evaluations for the commercial samples (not engineering samples) of the mask ROM version.

22.1 Memory Size Switching Register

The μ PD78F0974 allow users to select the internal memory capacity using the memory size switching register (IMS) so that the same memory map as that of the μ PD780973(A) with a different size of internal memory capacity can be achieved.

IMS is set by using an 8-bit memory manipulation instruction.

$\overline{\text{RESET}}$ input sets IMS to CFH.

Figure 22-1. Memory Size Switching Register (IMS) Format

Address: FFF0H After Reset: CFH R/W

Symbol	7	6	5	4	3	2	1	0
IMS	RAM2	RAM1	RAM0	0	ROM3	ROM2	ROM1	ROM0

RAM2	RAM1	RAM0	Internal High-Speed RAM Capacity Selection
0	0	0	768 bytes
1	1	0	1024 bytes
Other than above			Setting prohibited

ROM3	ROM2	ROM1	ROM0	Internal ROM Capacity Selection
0	1	1	0	24 Kbytes
1	0	0	0	32 Kbytes
Other than above				Setting prohibited

The IMS settings to obtain the same memory map as the μ PD780973(A) are shown in Table 22-2.

Table 22-2. Memory Size Switching Register Settings

Product	IMS Setting
μ PD780973(A)	06H

Caution With the μ PD780973(A), IMS must be set to 06H.

22.2 Flash Memory Programming

On-board writing of flash memory (with device mounted on target system) is supported.

On-board writing is done after connecting a dedicated flash writer (Flashpro II) to the host machine and target system.

Moreover, writing to flash memory can also be performed using a flash memory writing adapter connected to Flashpro II.

Remark Flashpro II is a product of Naitou Densai Machidaseisakusho Co., Ltd.

22.2.1 Selection of transmission method

Writing to flash memory is performed using Flashpro II and serial communication. Select the transmission method for writing from Table 22-3. For the selection of the transmission method, a format like the one shown in Figure 22-2 is used. The transmission methods are selected with the V_{PP} pulse numbers shown in Table 22-3.

Table 22-3. Transmission Method List

Transmission Method	Number of Channels	Pin Used	Number of V_{PP} Pulses
3-wire serial I/O	1	SI/P52 SO/P51 SCK/P50	0
UART	1	RxD/P53 TxD/P54	8
Pseudo 3-wire serial I/O	2	P05 (serial clock input) P06 (serial data output) P07 (serial data input)	12
		P95/S7 (serial clock input) P96/S6 (serial data output) P97/S5 (serial data input)	13

- Cautions**
1. Be sure to select the number of V_{PP} pulses shown in Table 22-3 for the transmission method.
 2. If performing write operations to flash memory with the UART transmission method, set the main system clock oscillation frequency to 4.19 MHz or higher.

Figure 22-2. Transmission Method Selection Format

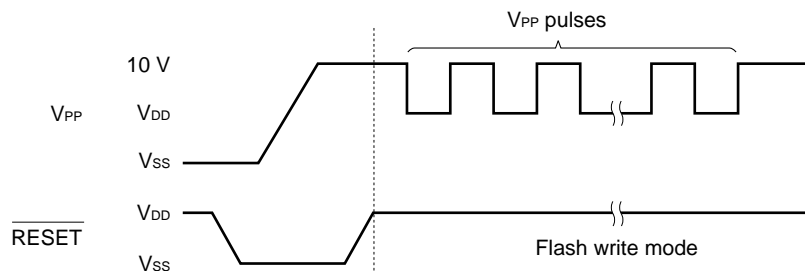

22.2.2 Flash memory programming function

Flash memory writing is performed through command and data transmit/receive operations using the selected transmission method. The main functions are listed in Table 22-4.

Table 22-4. Main Functions of Flash Memory Programming

Function	Description
Reset	Detects write stop and transmission synchronization.
Batch verify	Compares entire memory contents and input data.
Batch delete	Deletes the entire memory contents.
Batch blank check	Checks the deletion status of the entire memory.
High-speed write	Performs writing to flash memory according to write start address and number of write data (bytes).
Continuous write	Performs successive write operations using the data input with high-speed write operation.
Status	Checks the current operation mode and operation end.
Oscillation frequency setting	Inputs the resonator oscillation frequency information.
Delete time setting	Inputs the memory delete time.
Baud rate setting	Sets the transmission rate when the UART method is used.
Silicon signature read	Outputs the device name, memory capacity, and device block information.

22.2.3 Flashpro II connection

Connection of Flashpro II and the μ PD78F0974 differs depending on transmission method (3-wire serial I/O, UART, and pseudo 3-wire serial I/O). Each case of connection shows in Figures 22-3, 22-4, and 22-5.

Figure 22-3. Flashpro II Connection Using 3-Wire Serial I/O Method

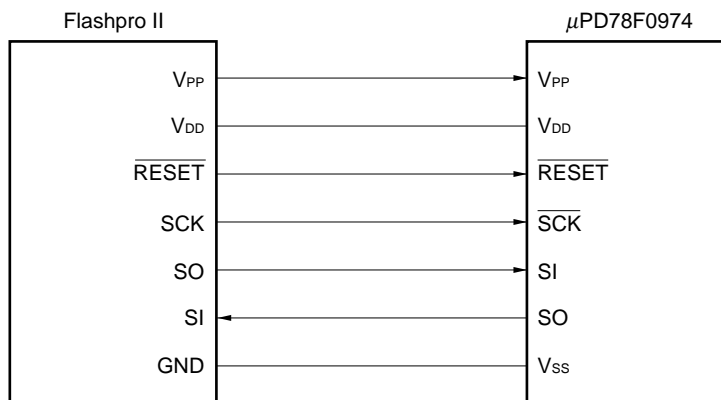

Figure 22-4. Flashpro II Connection Using UART Method

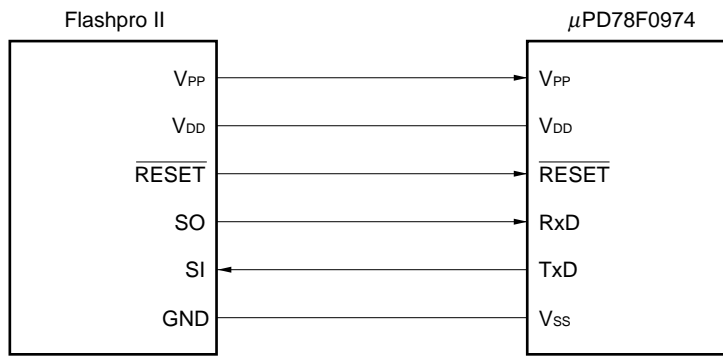
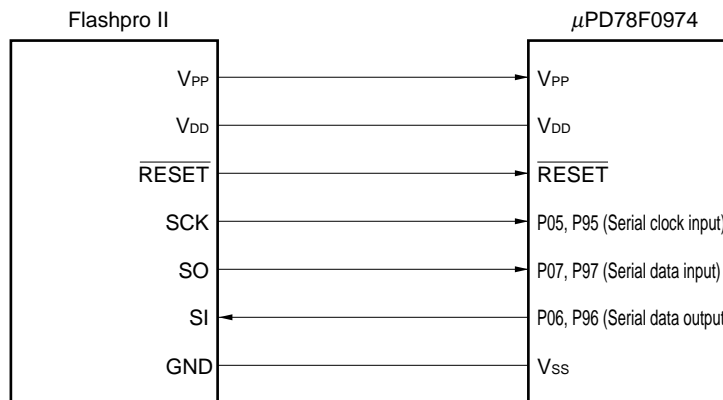

Figure 22-5. Flashpro II Connection Using Pseudo 3-Wire Serial I/O Method



[MEMO]

CHAPTER 23 INSTRUCTION SET

This chapter lists the instruction set of the μ PD780973 Subseries. For details of the operation and machine language (instruction code), refer to the separate document “**78K/0 Series User’s Manual—Instructions (U12326E)**.”

23.1 Legend for Operation List

23.1.1 Operand identifiers and description formats

Operands are described in “Operand” column of each instruction in accordance with the description format of the instruction operand identifier (refer to the assembler specifications for detail). When there are two or more description formats, select one of them. Alphabetic letters in capitals and symbols, #, !, \$ and [] are key words and must be described as they are. The meaning of the symbols are as follows.

- # : Immediate data
- ! : Absolute address
- \$: Relative address
- [] : Indirect address

In the case of immediate data, describe an appropriate numeric value or a label. When using a label, be sure to describe the #, !, \$, and [] symbols.

For operand register identifiers, r and rp, either function names (X, A, C, etc.) or absolute names (names in parentheses in the table below, R0, R1, R2, etc.) can be used for description.

Table 23-1. Operand Identifiers and Description Formats

Identifier	Description Format
r	X (R0), A (R1), C (R2), B (R3), E (R4), D (R5), L (R6), H (R7)
rp	AX (RP0), BC (RP1), DE (RP2), HL (RP3)
sfr	Special-function register symbol Note
sfrp	Special-function register symbol (16-bit manipulatable register even addresses only) Note
saddr	FE20H to FF1FH Immediate data or labels
saddrp	FE20H to FF1FH Immediate data or labels (even addresses only)
addr16	0000H to FFFFH Immediate data or labels (Only even addresses for 16-bit data transfer instructions)
addr11	0800H to 0FFFH Immediate data or labels
addr5	0040H to 007FH Immediate data or labels (even addresses only)
word	16-bit immediate data or label
byte	8-bit immediate data or label
bit	3-bit immediate data or label
RBn	RB0 to RB3

Note Addresses from FFD0H to FFDFH cannot be accessed with these operands.

Remark For special-function register symbols, refer to **Table 3-5 Special Function Register List**.

23.1.2 Description of “operation” column

A	: A register; 8-bit accumulator
X	: X register
B	: B register
C	: C register
D	: D register
E	: E register
H	: H register
L	: L register
AX	: AX register pair; 16-bit accumulator
BC	: BC register pair
DE	: DE register pair
HL	: HL register pair
PC	: Program counter
SP	: Stack pointer
PSW	: Program status word
CY	: Carry flag
AC	: Auxiliary carry flag
Z	: Zero flag
RBS	: Register bank select flag
IE	: Interrupt request enable flag
NMIS	: Non-maskable interrupt servicing flag
()	: Memory contents indicated by address or register contents in parentheses
x _H , x _L	: Higher 8 bits and lower 8 bits of 16-bit register
∧	: Logical product (AND)
∨	: Logical sum (OR)
⊕	: Exclusive logical sum (exclusive OR)
—	: Inverted data
addr16	: 16-bit immediate data or label
jdisp8	: Signed 8-bit data (displacement value)

23.1.3 Description of “flag operation” column

(Blank)	: Not affected
0	: Cleared to 0
1	: Set to 1
×	: Set/cleared according to the result
R	: Previously saved value is restored

23.2 Operation List

Instruction Group	Mnemonic	Operands	Byte	Clock		Operation	Flag				
				Note 1	Note 2		Z	AC	CY		
8-bit data transfer	MOV	r, #byte	2	4	–	r ← byte					
		saddr, #byte	3	6	7	(saddr) ← byte					
		sfr, #byte	3	–	7	sfr ← byte					
		A, r	Note 3	1	2	–	A ← r				
		r, A	Note 3	1	2	–	r ← A				
		A, saddr		2	4	5	A ← (saddr)				
		saddr, A		2	4	5	(saddr) ← A				
		A, sfr		2	–	5	A ← sfr				
		sfr, A		2	–	5	sfr ← A				
		A, !addr16		3	8	9	A ← (addr16)				
		!addr16, A		3	8	9	(addr16) ← A				
		PSW, #byte		3	–	7	PSW ← byte	x	x	x	
		A, PSW		2	–	5	A ← PSW				
		PSW, A		2	–	5	PSW ← A	x	x	x	
		A, [DE]		1	4	5	A ← (DE)				
		[DE], A		1	4	5	(DE) ← A				
		A, [HL]		1	4	5	A ← (HL)				
		[HL], A		1	4	5	(HL) ← A				
		A, [HL + byte]		2	8	9	A ← (HL + byte)				
		[HL + byte], A		2	8	9	(HL + byte) ← A				
		A, [HL + B]		1	6	7	A ← (HL + B)				
		[HL + B], A		1	6	7	(HL + B) ← A				
		A, [HL + C]		1	6	7	A ← (HL + C)				
		[HL + C], A		1	6	7	(HL + C) ← A				
		XCH	A, r	Note 3	1	2	–	A ↔ r			
			A, saddr		2	4	6	A ↔ (saddr)			
			A, sfr		2	–	6	A ↔ sfr			
			A, !addr16		3	8	10	A ↔ (addr16)			
	A, [DE]			1	4	6	A ↔ (DE)				
	A, [HL]			1	4	6	A ↔ (HL)				
A, [HL + byte]			2	8	10	A ↔ (HL + byte)					
A, [HL + B]			2	8	10	A ↔ (HL + B)					
A, [HL + C]			2	8	10	A ↔ (HL + C)					

- Notes**
1. When the internal high-speed RAM area is accessed or instruction with no data access
 2. When an area except the internal high-speed RAM area is accessed.
 3. Except “r = A”

Remark One instruction clock cycle is one cycle of the CPU clock (f_{CPU}) selected by the processor clock control register (PCC).

Instruction Group	Mnemonic	Operands	Byte	Clock		Operation	Flag		
				Note 1	Note 2		Z	AC	CY
16-bit data transfer	MOVW	rp, #word	3	6	–	rp ← word			
		saddrp, #word	4	8	10	(saddrp) ← word			
		sfrp, #word	4	–	10	sfrp ← word			
		AX, saddrp	2	6	8	AX ← (saddrp)			
		saddrp, AX	2	6	8	(saddrp) ← AX			
		AX, sfrp	2	–	8	AX ← sfrp			
		sfrp, AX	2	–	8	sfrp ← AX			
		AX, rp Note 3	1	4	–	AX ← rp			
		rp, AX Note 3	1	4	–	rp ← AX			
		AX, !addr16	3	10	12	AX ← (addr16)			
	!addr16, AX	3	10	12	(addr16) ← AX				
XCHW	AX, rp Note 3	1	4	–	AX ↔ rp				
8-bit operation	ADD	A, #byte	2	4	–	A, CY ← A + byte	×	×	×
		saddr, #byte	3	6	8	(saddr), CY ← (saddr) + byte	×	×	×
		A, r Note 4	2	4	–	A, CY ← A + r	×	×	×
		r, A	2	4	–	r, CY ← r + A	×	×	×
		A, saddr	2	4	5	A, CY ← A + (saddr)	×	×	×
		A, !addr16	3	8	9	A, CY ← A + (addr16)	×	×	×
		A, [HL]	1	4	5	A, CY ← A + (HL)	×	×	×
		A, [HL + byte]	2	8	9	A, CY ← A + (HL + byte)	×	×	×
		A, [HL + B]	2	8	9	A, CY ← A + (HL + B)	×	×	×
		A, [HL + C]	2	8	9	A, CY ← A + (HL + C)	×	×	×
	ADDC	A, #byte	2	4	–	A, CY ← A + byte + CY	×	×	×
		saddr, #byte	3	6	8	(saddr), CY ← (saddr) + byte + CY	×	×	×
		A, r Note 4	2	4	–	A, CY ← A + r + CY	×	×	×
		r, A	2	4	–	r, CY ← r + A + CY	×	×	×
		A, saddr	2	4	5	A, CY ← A + (saddr) + CY	×	×	×
		A, !addr16	3	8	9	A, CY ← A + (addr16) + CY	×	×	×
		A, [HL]	1	4	5	A, CY ← A + (HL) + CY	×	×	×
		A, [HL + byte]	2	8	9	A, CY ← A + (HL + byte) + CY	×	×	×
		A, [HL + B]	2	8	9	A, CY ← A + (HL + B) + CY	×	×	×
A, [HL + C]	2	8	9	A, CY ← A + (HL + C) + CY	×	×	×		

- Notes**
1. When the internal high-speed RAM area is accessed or instruction with no data access
 2. When an area except the internal high-speed RAM area is accessed
 3. Only when rp = BC, DE or HL
 4. Except “r = A”

Remark One instruction clock cycle is one cycle of the CPU clock (f_{cpu}) selected by the processor clock control register (PCC).

Instruction Group	Mnemonic	Operands	Byte	Clock		Operation	Flag		
				Note 1	Note 2		Z	AC	CY
8-bit operation	SUB	A, #byte	2	4	–	A, CY ← A – byte	×	×	×
		saddr, #byte	3	6	8	(saddr), CY ← (saddr) – byte	×	×	×
		A, r Note 3	2	4	–	A, CY ← A – r	×	×	×
		r, A	2	4	–	r, CY ← r – A	×	×	×
		A, saddr	2	4	5	A, CY ← A – (saddr)	×	×	×
		A, !addr16	3	8	9	A, CY ← A – (addr16)	×	×	×
		A, [HL]	1	4	5	A, CY ← A – (HL)	×	×	×
		A, [HL + byte]	2	8	9	A, CY ← A – (HL + byte)	×	×	×
		A, [HL + B]	2	8	9	A, CY ← A – (HL + B)	×	×	×
		A, [HL + C]	2	8	9	A, CY ← A – (HL + C)	×	×	×
	SUBC	A, #byte	2	4	–	A, CY ← A – byte – CY	×	×	×
		saddr, #byte	3	6	8	(saddr), CY ← (saddr) – byte – CY	×	×	×
		A, r Note 3	2	4	–	A, CY ← A – r – CY	×	×	×
		r, A	2	4	–	r, CY ← r – A – CY	×	×	×
		A, saddr	2	4	5	A, CY ← A – (saddr) – CY	×	×	×
		A, !addr16	3	8	9	A, CY ← A – (addr16) – CY	×	×	×
		A, [HL]	1	4	5	A, CY ← A – (HL) – CY	×	×	×
		A, [HL + byte]	2	8	9	A, CY ← A – (HL + byte) – CY	×	×	×
		A, [HL + B]	2	8	9	A, CY ← A – (HL + B) – CY	×	×	×
		A, [HL + C]	2	8	9	A, CY ← A – (HL + C) – CY	×	×	×
	AND	A, #byte	2	4	–	A ← A ∧ byte	×		
		saddr, #byte	3	6	8	(saddr) ← (saddr) ∧ byte	×		
		A, r Note 3	2	4	–	A ← A ∧ r	×		
		r, A	2	4	–	r ← r ∧ A	×		
		A, saddr	2	4	5	A ← A ∧ (saddr)	×		
		A, !addr16	3	8	9	A ← A ∧ (addr16)	×		
		A, [HL]	1	4	5	A ← A ∧ (HL)	×		
		A, [HL + byte]	2	8	9	A ← A ∧ (HL + byte)	×		
		A, [HL + B]	2	8	9	A ← A ∧ (HL + B)	×		
		A, [HL + C]	2	8	9	A ← A ∧ (HL + C)	×		

- Notes**
1. When the internal high-speed RAM area is accessed or instruction with no data access
 2. When an area except the internal high-speed RAM area is accessed
 3. Except “r = A”

Remark One instruction clock cycle is one cycle of the CPU clock (f_{cpu}) selected by the processor clock control register (PCC).

Instruction Group	Mnemonic	Operands	Byte	Clock		Operation	Flag		
				Note 1	Note 2		Z	AC	CY
8-bit operation	OR	A, #byte	2	4	–	$A \leftarrow A \vee \text{byte}$		x	
		saddr, #byte	3	6	8	$(\text{saddr}) \leftarrow (\text{saddr}) \vee \text{byte}$		x	
		A, r Note 3	2	4	–	$A \leftarrow A \vee r$		x	
		r, A	2	4	–	$r \leftarrow r \vee A$		x	
		A, saddr	2	4	5	$A \leftarrow A \vee (\text{saddr})$		x	
		A, !addr16	3	8	9	$A \leftarrow A \vee (\text{addr16})$		x	
		A, [HL]	1	4	5	$A \leftarrow A \vee (\text{HL})$		x	
		A, [HL + byte]	2	8	9	$A \leftarrow A \vee (\text{HL} + \text{byte})$		x	
		A, [HL + B]	2	8	9	$A \leftarrow A \vee (\text{HL} + B)$		x	
		A, [HL + C]	2	8	9	$A \leftarrow A \vee (\text{HL} + C)$		x	
	XOR	A, #byte	2	4	–	$A \leftarrow A \nabla \text{byte}$		x	
		saddr, #byte	3	6	8	$(\text{saddr}) \leftarrow (\text{saddr}) \nabla \text{byte}$		x	
		A, r Note 3	2	4	–	$A \leftarrow A \nabla r$		x	
		r, A	2	4	–	$r \leftarrow r \nabla A$		x	
		A, saddr	2	4	5	$A \leftarrow A \nabla (\text{saddr})$		x	
		A, !addr16	3	8	9	$A \leftarrow A \nabla (\text{addr16})$		x	
		A, [HL]	1	4	5	$A \leftarrow A \nabla (\text{HL})$		x	
		A, [HL + byte]	2	8	9	$A \leftarrow A \nabla (\text{HL} + \text{byte})$		x	
		A, [HL + B]	2	8	9	$A \leftarrow A \nabla (\text{HL} + B)$		x	
		A, [HL + C]	2	8	9	$A \leftarrow A \nabla (\text{HL} + C)$		x	
	CMP	A, #byte	2	4	–	$A - \text{byte}$	x	x	x
		saddr, #byte	3	6	8	$(\text{saddr}) - \text{byte}$	x	x	x
		A, r Note 3	2	4	–	$A - r$	x	x	x
		r, A	2	4	–	$r - A$	x	x	x
		A, saddr	2	4	5	$A - (\text{saddr})$	x	x	x
		A, !addr16	3	8	9	$A - (\text{addr16})$	x	x	x
		A, [HL]	1	4	5	$A - (\text{HL})$	x	x	x
A, [HL + byte]		2	8	9	$A - (\text{HL} + \text{byte})$	x	x	x	
A, [HL + B]		2	8	9	$A - (\text{HL} + B)$	x	x	x	
A, [HL + C]	2	8	9	$A - (\text{HL} + C)$	x	x	x		

- Notes**
1. When the internal high-speed RAM area is accessed or instruction with no data access
 2. When an area except the internal high-speed RAM area is accessed
 3. Except “r = A”

Remark One instruction clock cycle is one cycle of the CPU clock (f_{CPU}) selected by the processor clock control register (PCC).

Instruction Group	Mnemonic	Operands	Byte	Clock		Operation	Flag		
				Note 1	Note 2		Z	A	CY
16-bit operation	ADDW	AX, #word	3	6	–	AX, CY ← AX + word	×	×	×
	SUBW	AX, #word	3	6	–	AX, CY ← AX – word	×	×	×
	CMPW	AX, #word	3	6	–	AX – word	×	×	×
Multiply/divide	MULU	X	2	16	–	AX ← A × X			
	DIVUW	C	2	25	–	AX (Quotient), C (Remainder) ← AX ÷ C			
Increment/decrement	INC	r	1	2	–	r ← r + 1	×	×	
		saddr	2	4	6	(saddr) ← (saddr) + 1	×	×	
	DEC	r	1	2	–	r ← r – 1	×	×	
		saddr	2	4	6	(saddr) ← (saddr) – 1	×	×	
	INCW	rp	1	4	–	rp ← rp + 1			
DECW	rp	1	4	–	rp ← rp – 1				
Rotate	ROR	A, 1	1	2	–	(CY, A ₇ ← A ₀ , A _{m-1} ← A _m) × 1 time			×
	ROL	A, 1	1	2	–	(CY, A ₀ ← A ₇ , A _{m+1} ← A _m) × 1 time			×
	RORC	A, 1	1	2	–	(CY ← A ₀ , A ₇ ← CY, A _{m-1} ← A _m) × 1 time			×
	ROLC	A, 1	1	2	–	(CY ← A ₇ , A ₀ ← CY, A _{m+1} ← A _m) × 1 time			×
	ROR4	[HL]	2	10	12	A ₃₋₀ ← (HL) ₃₋₀ , (HL) ₇₋₄ ← A ₃₋₀ , (HL) ₃₋₀ ← (HL) ₇₋₄			
	ROL4	[HL]	2	10	12	A ₃₋₀ ← (HL) ₇₋₄ , (HL) ₃₋₀ ← A ₃₋₀ , (HL) ₇₋₄ ← (HL) ₃₋₀			
BCD adjust	ADJBA		2	4	–	Decimal Adjust Accumulator after Addition	×	×	×
	ADJBS		2	4	–	Decimal Adjust Accumulator after Subtract	×	×	×
Bit manipulate	MOV1	CY, saddr.bit	3	6	7	CY ← (saddr.bit)			×
		CY, sfr.bit	3	–	7	CY ← sfr.bit			×
		CY, A.bit	2	4	–	CY ← A.bit			×
		CY, PSW.bit	3	–	7	CY ← PSW.bit			×
		CY, [HL].bit	2	6	7	CY ← (HL).bit			×
		saddr.bit, CY	3	6	8	(saddr.bit) ← CY			
		sfr.bit, CY	3	–	8	sfr.bit ← CY			
		A.bit, CY	2	4	–	A.bit ← CY			
		PSW.bit, CY	3	–	8	PSW.bit ← CY	×	×	
[HL].bit, CY	2	6	8	(HL).bit ← CY					

- Notes**
1. When the internal high-speed RAM area is accessed or instruction with no data access
 2. When an area except the internal high-speed RAM area is accessed

Remark One instruction clock cycle is one cycle of the CPU clock (f_{CPU}) selected by the processor clock control register (PCC).

Instruction Group	Mnemonic	Operands	Byte	Clock		Operation	Flag		
				Note 1	Note 2		Z	AC	CY
Bit manipulate	AND1	CY, saddr.bit	3	6	7	$CY \leftarrow CY \wedge (\text{saddr.bit})$			×
		CY, sfr.bit	3	–	7	$CY \leftarrow CY \wedge \text{sfr.bit}$			×
		CY, A.bit	2	4	–	$CY \leftarrow CY \wedge A.\text{bit}$			×
		CY, PSW.bit	3	–	7	$CY \leftarrow CY \wedge \text{PSW.bit}$			×
		CY, [HL].bit	2	6	7	$CY \leftarrow CY \wedge (\text{HL}).\text{bit}$			×
	OR1	CY, saddr.bit	3	6	7	$CY \leftarrow CY \vee (\text{saddr.bit})$			×
		CY, sfr.bit	3	–	7	$CY \leftarrow CY \vee \text{sfr.bit}$			×
		CY, A.bit	2	4	–	$CY \leftarrow CY \vee A.\text{bit}$			×
		CY, PSW.bit	3	–	7	$CY \leftarrow CY \vee \text{PSW.bit}$			×
		CY, [HL].bit	2	6	7	$CY \leftarrow CY \vee (\text{HL}).\text{bit}$			×
	XOR1	CY, saddr.bit	3	6	7	$CY \leftarrow CY \oplus (\text{saddr.bit})$			×
		CY, sfr.bit	3	–	7	$CY \leftarrow CY \oplus \text{sfr.bit}$			×
		CY, A.bit	2	4	–	$CY \leftarrow CY \oplus A.\text{bit}$			×
		CY, PSW.bit	3	–	7	$CY \leftarrow CY \oplus \text{PSW.bit}$			×
		CY, [HL].bit	2	6	7	$CY \leftarrow CY \oplus (\text{HL}).\text{bit}$			×
	SET1	saddr.bit	2	4	6	$(\text{saddr.bit}) \leftarrow 1$			
		sfr.bit	3	–	8	$\text{sfr.bit} \leftarrow 1$			
		A.bit	2	4	–	$A.\text{bit} \leftarrow 1$			
		PSW.bit	2	–	6	$\text{PSW.bit} \leftarrow 1$	×	×	×
		[HL].bit	2	6	8	$(\text{HL}).\text{bit} \leftarrow 1$			
	CLR1	saddr.bit	2	4	6	$(\text{saddr.bit}) \leftarrow 0$			
		sfr.bit	3	–	8	$\text{sfr.bit} \leftarrow 0$			
		A.bit	2	4	–	$A.\text{bit} \leftarrow 0$			
		PSW.bit	2	–	6	$\text{PSW.bit} \leftarrow 0$	×	×	×
		[HL].bit	2	6	8	$(\text{HL}).\text{bit} \leftarrow 0$			
	SET1	CY	1	2	–	$CY \leftarrow 1$			1
	CLR1	CY	1	2	–	$CY \leftarrow 0$			0
	NOT1	CY	1	2	–	$CY \leftarrow \overline{CY}$			×

- Notes**
1. When the internal high-speed RAM area is accessed or instruction with no data access
 2. When an area except the internal high-speed RAM area is accessed

Remark One instruction clock cycle is one cycle of the CPU clock (f_{CPU}) selected by the processor clock control register (PCC).

Instruction Group	Mnemonic	Operands	Byte	Clock		Operation	Flag		
				Note 1	Note 2		Z	AC	CY
Call/return	CALL	!addr16	3	7	–	$(SP - 1) \leftarrow (PC + 3)_H, (SP - 2) \leftarrow (PC + 3)_L,$ $PC \leftarrow \text{addr16}, SP \leftarrow SP - 2$			
	CALLF	!addr11	2	5	–	$(SP - 1) \leftarrow (PC + 2)_H, (SP - 2) \leftarrow (PC + 2)_L,$ $PC_{15-11} \leftarrow 00001, PC_{10-0} \leftarrow \text{addr11},$ $SP \leftarrow SP - 2$			
	CALLT	[addr5]	1	6	–	$(SP - 1) \leftarrow (PC + 1)_H, (SP - 2) \leftarrow (PC + 1)_L,$ $PC_H \leftarrow (00000000, \text{addr5} + 1),$ $PC_L \leftarrow (00000000, \text{addr5}),$ $SP \leftarrow SP - 2$			
	BRK		1	6	–	$(SP - 1) \leftarrow PSW, (SP - 2) \leftarrow (PC + 1)_H,$ $(SP - 3) \leftarrow (PC + 1)_L, PC_H \leftarrow (003FH),$ $PC_L \leftarrow (003EH), SP \leftarrow SP - 3, IE \leftarrow 0$			
	RET		1	6	–	$PC_H \leftarrow (SP + 1), PC_L \leftarrow (SP),$ $SP \leftarrow SP + 2$			
	RETI		1	6	–	$PC_H \leftarrow (SP + 1), PC_L \leftarrow (SP),$ $PSW \leftarrow (SP + 2), SP \leftarrow SP + 3,$ $NMIS \leftarrow 0$	R	R	R
	RETB		1	6	–	$PC_H \leftarrow (SP + 1), PC_L \leftarrow (SP),$ $PSW \leftarrow (SP + 2), SP \leftarrow SP + 3$	R	R	R
Stack manipulate	PUSH	PSW	1	2	–	$(SP - 1) \leftarrow PSW, SP \leftarrow SP - 1$			
		rp	1	4	–	$(SP - 1) \leftarrow rp_H, (SP - 2) \leftarrow rp_L,$ $SP \leftarrow SP - 2$			
	POP	PSW	1	2	–	$PSW \leftarrow (SP), SP \leftarrow SP + 1$	R	R	R
		rp	1	4	–	$rp_H \leftarrow (SP + 1), rp_L \leftarrow (SP),$ $SP \leftarrow SP + 2$			
	MOVW	SP, #word	4	–	10	$SP \leftarrow \text{word}$			
		SP, AX	2	–	8	$SP \leftarrow AX$			
AX, SP		2	–	8	$AX \leftarrow SP$				
Unconditional branch	BR	!addr16	3	6	–	$PC \leftarrow \text{addr16}$			
		\$addr16	2	6	–	$PC \leftarrow PC + 2 + \text{jdisp8}$			
		AX	2	8	–	$PC_H \leftarrow A, PC_L \leftarrow X$			
Conditional branch	BC	\$addr16	2	6	–	$PC \leftarrow PC + 2 + \text{jdisp8}$ if CY = 1			
	BNC	\$addr16	2	6	–	$PC \leftarrow PC + 2 + \text{jdisp8}$ if CY = 0			
	BZ	\$addr16	2	6	–	$PC \leftarrow PC + 2 + \text{jdisp8}$ if Z = 1			
	BNZ	\$addr16	2	6	–	$PC \leftarrow PC + 2 + \text{jdisp8}$ if Z = 0			

- Notes**
1. When the internal high-speed RAM area is accessed or instruction with no data access
 2. When an area except the internal high-speed RAM area is accessed

Remark One instruction clock cycle is one cycle of the CPU clock (f_{CPU}) selected by the processor clock control register (PCC).

Instruction Group	Mnemonic	Operands	Byte	Clock		Operation	Flag		
				Note 1	Note 2		Z	AC	CY
Conditional branch	BT	saddr.bit, \$addr16	3	8	9	PC ← PC + 3 + jdisp8 if (saddr.bit) = 1			
		sfr.bit, \$addr16	4	–	11	PC ← PC + 4 + jdisp8 if sfr.bit = 1			
		A.bit, \$addr16	3	8	–	PC ← PC + 3 + jdisp8 if A.bit = 1			
		PSW.bit, \$addr16	3	–	9	PC ← PC + 3 + jdisp8 if PSW.bit = 1			
		[HL].bit, \$addr16	3	10	11	PC ← PC + 3 + jdisp8 if (HL).bit = 1			
	BF	saddr.bit, \$addr16	4	10	11	PC ← PC + 4 + jdisp8 if (saddr.bit) = 0			
		sfr.bit, \$addr16	4	–	11	PC ← PC + 4 + jdisp8 if sfr.bit = 0			
		A.bit, \$addr16	3	8	–	PC ← PC + 3 + jdisp8 if A.bit = 0			
		PSW.bit, \$addr16	4	–	11	PC ← PC + 4 + jdisp8 if PSW.bit = 0			
		[HL].bit, \$addr16	3	10	11	PC ← PC + 3 + jdisp8 if (HL).bit = 0			
	BTCLR	saddr.bit, \$addr16	4	10	12	PC ← PC + 4 + jdisp8 if (saddr.bit) = 1 then reset (saddr.bit)			
		sfr.bit, \$addr16	4	–	12	PC ← PC + 4 + jdisp8 if sfr.bit = 1 then reset sfr.bit			
		A.bit, \$addr16	3	8	–	PC ← PC + 3 + jdisp8 if A.bit = 1 then reset A.bit			
		PSW.bit, \$addr16	4	–	12	PC ← PC + 4 + jdisp8 if PSW.bit = 1 then reset PSW.bit	×	×	×
		[HL].bit, \$addr16	3	10	12	PC ← PC + 3 + jdisp8 if (HL).bit = 1 then reset (HL).bit			
DBNZ	B, \$addr16	2	6	–	B ← B – 1, then PC ← PC + 2 + jdisp8 if B ≠ 0				
	C, \$addr16	2	6	–	C ← C – 1, then PC ← PC + 2 + jdisp8 if C ≠ 0				
	saddr, \$addr16	3	8	10	(saddr) ← (saddr) – 1, then PC ← PC + 3 + jdisp8 if (saddr) ≠ 0				
CPU control	SEL	RBn	2	4	–	RBS1, 0 ← n			
	NOP		1	2	–	No Operation			
	EI		2	–	6	IE ← 1 (Enable Interrupt)			
	DI		2	–	6	IE ← 0 (Disable Interrupt)			
	HALT		2	6	–	Set HALT Mode			
	STOP		2	6	–	Set STOP Mode			

- Notes**
1. When the internal high-speed RAM area is accessed or instruction with no data access
 2. When an area except the internal high-speed RAM area is accessed

Remark One instruction clock cycle is one cycle of the CPU clock (f_{CPU}) selected by the processor clock control register (PCC).

23.3 Instructions Listed by Addressing Type

(1) 8-bit instructions

MOV, XCH, ADD, ADC, SUB, SBC, AND, OR, XOR, CMP, MULU, DIVUW, INC, DEC, ROR, ROL, RORC, ROLC, ROR4, ROL4, PUSH, POP, DBNZ

Second Operand First Operand	#byte	A	r ^{Note}	sfr	saddr	laddr16	PSW	[DE]	[HL]	[HL + byte] [HL + B] [HL + C]	\$addr16	1	None
A	ADD ADDC SUB SUBC AND OR XOR CMP		MOV XCH ADD ADDC SUB SUBC AND OR XOR CMP	MOV XCH	MOV XCH ADD ADDC SUB SUBC AND OR XOR CMP	MOV XCH ADD ADDC SUB SUBC AND OR XOR CMP	MOV	MOV XCH	MOV XCH ADD ADDC SUB SUBC AND OR XOR CMP	MOV XCH ADD ADDC SUB SUBC AND OR XOR CMP		ROR ROL RORC ROLC	
r	MOV	MOV ADD ADDC SUB SUBC AND OR XOR CMP											INC DEC
B, C											DBNZ		
sfr	MOV	MOV											
saddr	MOV ADD ADDC SUB SUBC AND OR XOR CMP	MOV									DBNZ		INC DEC
laddr16		MOV											
PSW	MOV	MOV											PUSH POP
[DE]		MOV											
[HL]		MOV											ROR4 ROL4
[HL + byte] [HL + B] [HL + C]		MOV											
X													MULU
C													DIVUW

Note Except r = A

(2) 16-bit instructions

MOVW, XCHW, ADDW, SUBW, CMPW, PUSH, POP, INCW, DECW

Second Operand 1st Operand	#word	AX	rp ^{Note}	sfrp	saddrp	!addr16	SP	None
AX	ADDW SUBW CMPW		MOVW XCHW	MOVW	MOVW	MOVW	MOVW	
rp	MOVW	MOVW ^{Note}						INCW DECW PUSH POP
sfrp	MOVW	MOVW						
saddrp	MOVW	MOVW						
!addr16		MOVW						
SP	MOVW	MOVW						

Note Only when rp = BC, DE, HL

(3) Bit manipulation instructions

MOV1, AND1, OR1, XOR1, SET1, CLR1, NOT1, BT, BF, BTCLR

Second Operand First Operand	A.bit	sfr.bit	saddr.bit	PSW.bit	[HL].bit	CY	\$addr16	None
A.bit						MOV1	BT BF BTCLR	SET1 CLR1
sfr.bit						MOV1	BT BF BTCLR	SET1 CLR1
saddr.bit						MOV1	BT BF BTCLR	SET1 CLR1
PSW.bit						MOV1	BT BF BTCLR	SET1 CLR1
[HL].bit						MOV1	BT BF BTCLR	SET1 CLR1
CY	MOV1 AND1 OR1 XOR1	MOV1 AND1 OR1 XOR1	MOV1 AND1 OR1 XOR1	MOV1 AND1 OR1 XOR1	MOV1 AND1 OR1 XOR1			SET1 CLR1 NOT1

(4) Call/branch instructions

CALL, CALLF, CALLT, BR, BC, BNC, BZ, BNZ, BT, BF, BTCLR, DBNZ

Second Operand First Operand	AX	!addr16	!addr11	[addr5]	\$addr16
Basic instruction	BR	CALL BR	CALLF	CALLT	BR BC BNC BZ BNZ
Compound instruction					BT BF BTCLR DBNZ

(5) Other instructions

ADJBA, ADJBS, BRK, RET, RETI, RETB, SEL, NOP, EI, DI, HALT, STOP

[MEMO]

★

APPENDIX A DEVELOPMENT TOOLS

The following development tools are available for the development of systems that employ the μ PD780973 Subseries.

Figure A-1 shows the development tool configuration.

Figure A-1. Development Tool Configuration (1/2)

(1) When using in-circuit emulator IE-78K0-NS

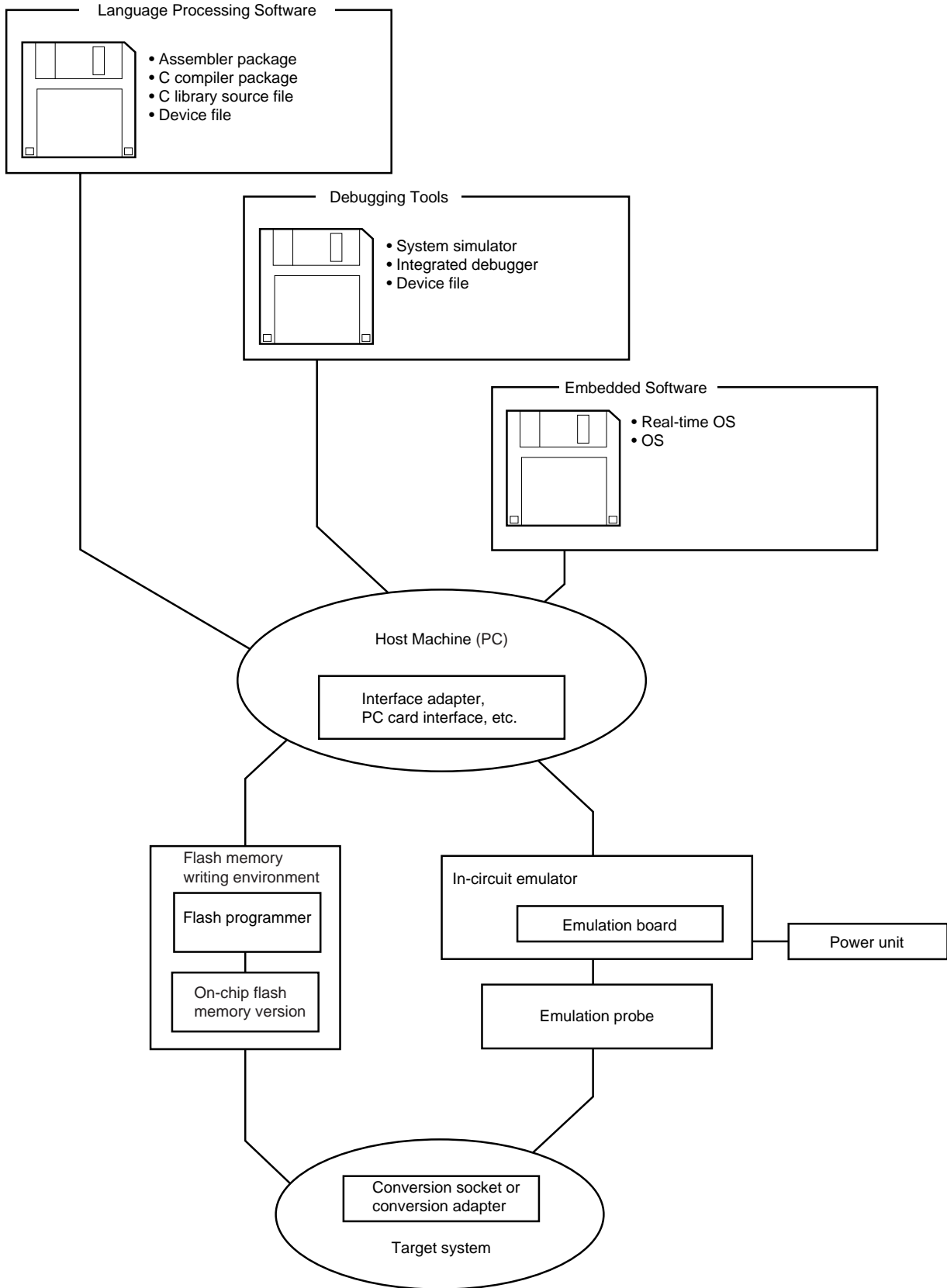
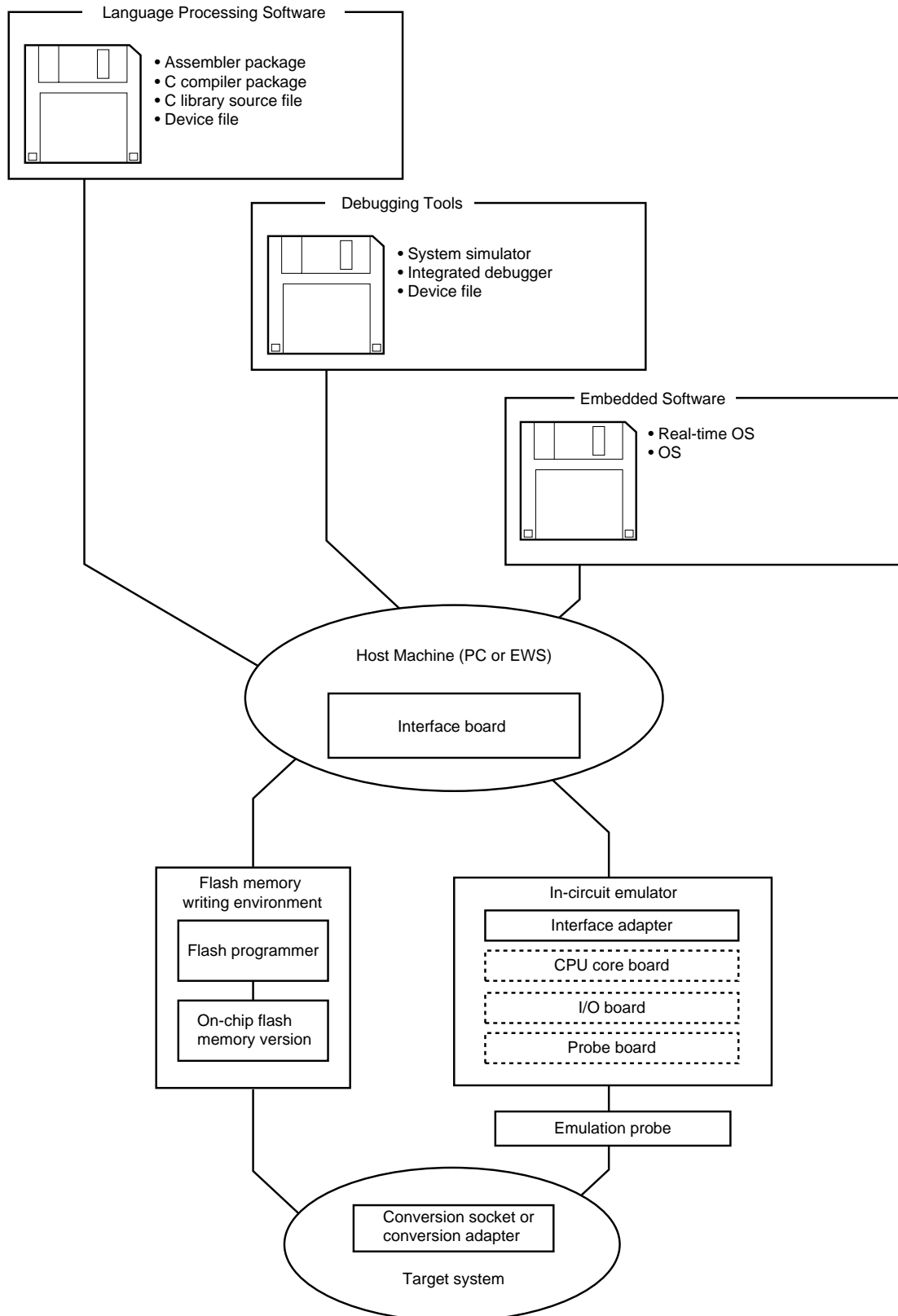

Figure A-1. Development Tool Configuration (2/2)

(2) When using in-circuit emulator IE-78001-R-A



Remark The tool enclosed in a broken line depends on the development environment. Refer to **A.3.1 Hardware**.

A.1 Language Processing Software

<p>RA78K/0 Assembler Package</p>	<p>This assembler converts programs written in mnemonics into an object code executable with a microcontroller. Further, this assembler is provided with functions capable of automatically creating symbol tables and branch instruction optimization. This assembler is used in combination with an optional device file (DF780974). <Caution when using in PC environment> This assembler package is a DOS-based application, however using Project Manager, which is included in the assembler package, enables use of this assembler in a Windows environment.</p>
<p>Part Number: μSxxxxRA78K0</p>	
<p>CC78K/0 C Compiler Package</p>	<p>This compiler converts programs written in C language into an object code executable with a microcontroller. This compiler is used in combination with an optional assembler package (RA78K/0) and device file (DF780974). <Caution when using in PC environment> This C compiler package is a DOS-based application, however using Project Manager, which is included in the assembler package, enables use of this compiler in a Windows environment.</p>
<p>Part Number: μSxxxxCC78K0</p>	
<p>DF780974 Notes 1, 2 Device File</p>	<p>This file contains information peculiar to the device. This file is used in combination with each optional tools RA78K/0, CC78K/0, SM78K0, ID78K0-NS, and ID78K0. Supported OS and host machine depend on each tool.</p>
<p>Part Number: μSxxxxDF780974</p>	
<p>CC78K/0-L C Library Source File</p>	<p>This is a source of functions configuring the object library included in the C compiler package. It is required for matching the object library included in the C compiler package with to the customer's specifications. Operation environment does not depend on OS because the source file is used.</p>
<p>Part Number: μSxxxxCC78K0-L</p>	

- Notes** 1. The DF780974 is used in common with the RA78K/0, CC78K/0, SM78K0, ID78K0-NS, and ID78K0.
2. Under development

Remark xxxx in the part number differs depending on the host machine and OS used.

μ SxxxxRA78K0
 μ SxxxxCC78K0
 μ SxxxxDF780974
 μ SxxxxCC78K0-L

xxxx	Host Machine	OS	Supply Medium
AA13	PC-9800 Series	Windows Japanese version ^{Notes 1, 2}	3.5-inch 2HD FD
AB13	IBM PC/AT™ and compatibles	Windows Japanese version ^{Notes 1, 2}	3.5-inch 2HC FD
BB13		Windows English version ^{Notes 1, 2}	
3P16	HP9000 Series 700™	HP-UX™ (Rel. 9.05)	DAT (DDS)
3K13	SPARCstation™	SunOS™ (Rel. 4.1.4)	3.5-inch 2HC FD
3K15			1/4-inch CGMT
3R13	NEWS™ (RISC)	NEWS-OS™ (Rel. 6.1)	3.5-inch 2HC FD

Notes 1. DOS is also supported.
 2. WindowsNT™ is not supported.

A.2 Flash Memory Writing Tools

Flashpro II (FL-PR2) Flash Writer	Dedicated flash writer for microcontrollers with on-chip flash memory.
--------------------------------------	--

Remark Flashpro II is a product of Naitou Densei Machidaseisakusho Co., Ltd.
 Naitou Densei Machidaseisakusho Co., Ltd. (TEL +81-44-822-3813)

A.3 Debugging Tools

A.3.1 Hardware (1/2)

(1) When using in-circuit emulator IE-78K0-NS

IE-78K0-NS Note In-circuit Emulator	This in-circuit emulator is used to debug hardware and software when developing application systems using the 78K/0 Series. It supports the integrated debugger (ID78K0-NS). This emulator is used in combination with a power unit, an emulation probe, and an interface adapter for connection to a host machine.
IE-70000-MC-PS-B Power Unit	This is an adapter for power supply from a receptacle of 100-V to 240-V AC.
IE-70000-98-IF-C Note Interface Adapter	This adapter is required when using the PC-9800 Series computer (except notebook type) as the IE-78K0-NS host machine.
IE-70000-CD-IF Note PC Card Interface	These PC card and interface cable are required when using a PC-9800 Series notebook as the IE-78K0-NS host machine.
IE-70000-PC-IF-C Note Interface Adapter	This adapter is required when using an IBM PC/AT or compatible as the IE-78K0-NS host machine.
IE-780974-NS-EM1 Note Emulation Board	This board is used to emulate the peripheral hardware that is peculiar to the device. This board is used in combination with an in-circuit emulator.
EP-80GF-NS Emulation Probe	This probe is used to connect an in-circuit emulator and target system. It is for 80-pin plastic QFPs (GF-3B9 type).
TGF-080RAP Conversion Adapter (Refer to Figure A-2)	This conversion adapter is used to connect a target system board designed to allow mounting of an 80-pin plastic QFP (GF-3B9 type) and the EP80GF-NS.

Note Under development

- Remarks 1.** TGF-080RAP is a product of TOKYO ELETECH Corporation.
 For inquiry: DAIMARU KOUGYOU Corporation
 Phone: +81-3-3820-7112 Tokyo Electronic Components Division
 +81-6-244-6672 Osaka Electronic Components Division
- 2.** The TGF-080RAP is sold in single units.

A.3.1 Hardware (2/2)

(2) When using in-circuit emulator IE-78001-R-A

IE-78001-R-A ^{Note} In-circuit Emulator	This in-circuit emulator is used to debug hardware and software when developing application systems using the 78K/0 Series. It supports the integrated debugger (ID78K0). This emulator is used in combination with an emulation probe and an interface adapter for connection to a host machine.
IE-70000-98-IF-B or IE-70000-98-IF-C ^{Note} Interface Adapter	This adapter is required when using the PC-9800 Series computer (except notebook type) as the IE-78001-R-A host machine.
IE-70000-PC-IF-B or IE-70000-PC-IF-C ^{Note} Interface Adapter	This adapter is required when using an IBM PC/AT or compatible as the IE-78001-R-A host machine.
IE-78000-R-SV3 Interface Adapter	This is an adapter and cable when an EWS is used as the host machine for the IE-78001-R-A and is connected to the board in the IE-78001-R-A. 10Base-5 is supported as Ethernet™. For the other methods, a commercially available conversion adapter is necessary.
IE-78K0-SL-EM ^{Note} CPU Core Board	This board is used to emulate a 78K/0 Series CPU. This board is used in combination with an in-circuit emulator and probe board.
IE-780974-SL-EM1 Probe Board	This board is used to perform mask option settings and pin connection changes.
EP-80GF-SL Emulation Probe	This probe is used to connect an in-circuit emulator and target system. It is for 80-pin plastic QFPs (GF-3B9 type). An 80-pin conversion socket (TGF-080RAP) is included to facilitate target system development.
	TGF-080RAP Conversion Adapter (See Figure A-2)

Note Under development

- Remarks 1.** TGF-080RAP is a product of TOKYO ELETECH Corporation.
For inquiry: DAIMARU KOUGYOU Corporation
Phone: +81-3-3820-7112 Tokyo Electronic Components Division
+81-6-244-6672 Osaka Electronic Components Division
- 2.** The TGF-080RAP is sold in single units.

A.3.2 Software (1/2)

SM78K0 System Simulator	This system simulator is used to perform debugging at C source level or assembler level while simulating the operation of the target system on a host machine. The SM78K0 operates on Windows. Use of the SM78K0 allows the execution of application logical testing and performance testing on an independent basis from hardware development without having to use an in-circuit emulator, thereby providing higher development efficiency and software quality. The SM78K0 is used in combination with the optional device file (DF780974). Part Number: μ SxxxxSM78K0
----------------------------	---

Remark xxxx in the part number differs depending on the host machine and OS used.

μ SxxxxSM78K0

xxxx	Host Machine	OS	Supply Medium
AA13	PC-9800 Series	Windows Japanese version Note	3.5-inch 2HD FD
AB13	IBM PC/AT and compatibles	Windows Japanese version Note	3.5-inch 2HC FD
BB13		Windows English version Note	

Note WindowsNT is not supported.

A.3.2 Software (2/2)

ID78K0-NS Note Integrated Debugger (Supports in-circuit emulator IE-78K0-NS)	This is a control program used to debug the 78K/0 Series. The graphical user interfaces employed are Windows for personal computers and OSF/ Motif™ for EWSs, offering the standard appearance and operability typical of these interfaces. Further, debugging functions supporting C language are reinforced, and the trace result can be displayed in C language level by using a window integrating function that associates the source program, disassemble display, and memory display with the trace result. In addition, it can enhance the debugging efficiency of a program using a real-time OS by incorporating function expansion modules such as a task debugger and system performance analyzer. This debugger is used in combination with an optional device file (DF780974). Part Number: μ SxxxxID78K0-NS, μ SxxxxID78K0
ID78K0 Integrated Debugger (Supports in-circuit emulator IE-78001-R-A)	

Note Under development

Remark xxxx in the part number differs depending on the host machine and OS used.

μ SxxxxID78K0-NS

xxxx	Host Machine	OS	Supply Medium
AA13	PC-9800 Series	Windows Japanese version Note	3.5-inch 2HD FD
AB13	IBM PC/AT and compatibles	Windows Japanese version Note	3.5-inch 2HC FD
BB13		Windows English version Note	

Note WindowsNT is not supported.

μ SxxxxID78K0

xxxx	Host Machine	OS	Supply Medium
AA13	PC-9800 Series	Windows Japanese version Note	3.5-inch 2HD FD
AB13	IBM PC/AT and compatibles	Windows Japanese version Note	3.5-inch 2HC FD
BB13		Windows English version Note	
3P16	HP9000 Series 700	HP-UX (Rel. 9.05)	DAT (DDS)
3K13	SPARCstation	SunOS (Rel. 4.1.4)	3.5-inch 2HC FD
3K15			1/4-inch CGMT
3R13	NEWS (RISC)	NEWS-OS (Rel. 6.1)	3.5-inch 2HC FD

Note WindowsNT is not supported.

A.4 Upgrading Former In-circuit Emulator for 78K/0 Series to IE-78001-R-A

If you have a former in-circuit emulator for the 78K/0 Series (IE-78000-R or IE-78000-R-A), your in-circuit emulator can be upgraded to be equivalent to the IE-78001-R-A in-circuit emulator by simply replacing the break board with the IE-78001-R-BK (under development).

Table A-1. Upgrading Former In-circuit Emulator for 78K/0 Series to IE-78001-R-A

In-circuit Emulator	Cabinet Upgrading ^{Note}	Board to be Purchased
IE-78000-R	Required	IE-78001-R-BK
IE-78000-R-A	Not required	

Note To upgrade your cabinet, bring it to NEC.

Dimensions of Conversion Adapter (TGF-080RAP)

Figure A-2. Dimensions of TGF-080RAP (Reference)

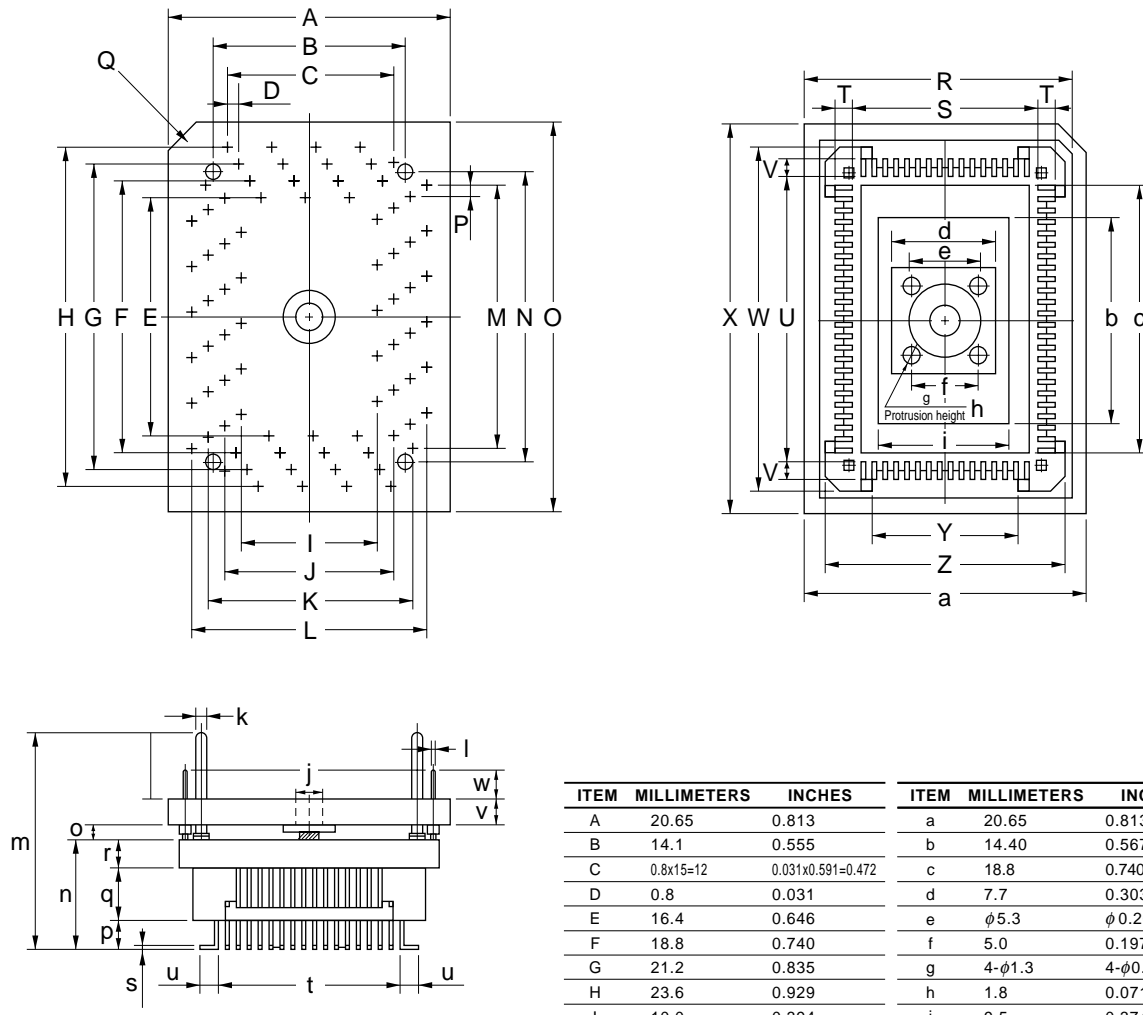

ITEM	MILLIMETERS	INCHES	ITEM	MILLIMETERS	INCHES
A	20.65	0.813	a	20.65	0.813
B	14.1	0.555	b	14.40	0.567
C	0.8x15=12	0.031x0.591=0.472	c	18.8	0.740
D	0.8	0.031	d	7.7	0.303
E	16.4	0.646	e	φ5.3	φ0.209
F	18.8	0.740	f	5.0	0.197
G	21.2	0.835	g	4-φ1.3	4-φ0.051
H	23.6	0.929	h	1.8	0.071
I	10.0	0.394	i	9.5	0.374
J	12.4	0.488	j	φ3.55	φ0.140
K	14.8	0.583	k	φ0.9	φ0.035
L	17.2	0.677	l	φ0.3	φ0.012
M	0.8x23=18.4	0.031x0.906=0.724	m	(16.95)	(0.667)
N	20.5	0.807	n	7.35	0.289
O	27.05	1.065	o	1.2	0.047
P	0.8	0.031	p	1.85	0.073
Q	C 2.0	C 0.079	q	3.5	0.138
R	18.65	0.734	r	2.0	0.079
S	13.35	0.526	s	0.25	0.010
T	1.325	0.052	t	13.6	0.535
U	19.75	0.778	u	1.2	0.047
V	1.125	0.044	v	2.4	0.094
W	23.55	0.927	w	2.7	0.106
X	27.05	1.065			
Y	10.6	0.417			
Z	17.1	0.673			

TGF-080RAP-G0

Note: Product of TOKYO ELETECH CORPORATION.

[MEMO]

APPENDIX B EMBEDDED SOFTWARE

For efficient development and maintenance of the μ PD780973 Subseries, the following embedded software products are available.

Real-Time OS (1/2)

RX78K/0 Real-time OS	RX78K/0 is a real-time OS conforming with the μ ITRON specifications. Tool (configurator) for generating nucleus of RX78K/0 and plural information tables is supplied. Used in combination with an optional assembler package (RA78K/0) and device file (DF780974). <Caution when using in PC environment> Real-time OS is a DOS-based application. Use DOS prompt in Windows. <hr/> Part number: μ SxxxxRX78013- $\Delta\Delta\Delta\Delta$
-------------------------	--

Caution When purchasing the RX78K/0, fill in the purchase application form in advance and sign the User Agreement.

Remark xxxx and $\Delta\Delta\Delta\Delta$ in the part number differ depending on the host machine and OS used.

μ SxxxxRX78013- $\Delta\Delta\Delta\Delta$

$\Delta\Delta\Delta\Delta$	Product Outline	Upper Limit of Mass-Production Quantity
001	Evaluation object	Do not use for mass-produced products.
100K	Object for mass-produced product	0.1 million units
001M		1 million units
010M		10 million units
S01	Source program	Source program for mass-produced object

xxxx	Host Machine	OS	Supply Medium
AA13	PC-9800 Series	Windows Japanese version Notes 1, 2	3.5-inch 2HD FD
AB13	IBM PC/AT and compatibles	Windows Japanese version Notes 1, 2	3.5-inch 2HC FD
BB13		Windows English version Notes 1, 2	
3P16	HP9000 Series 700	HP-UX (Rel. 9.05)	DAT (DDS)
3K13	SPARCstation	SunOS (Rel. 4.1.4)	3.5-inch 2HC FD
3K15			1/4-inch CGMT
3R13	NEWS (RISC)	NEWS-OS (Rel. 6.1)	3.5-inch 2HC FD

- Notes**
1. DOS is also supported.
 2. WindowsNT is not supported.

Real-Time OS (2/2)

MX78K0 OS	<p>μITRON specification subset OS. Nucleus of MX78K0 is supplied. This OS performs task management, event management, and time management. It controls the task execution sequence for task management and selects the task to be executed next. <Caution when using in PC environment> MX78K0 is a DOS-based application. Use DOS prompt in Windows.</p>
	Part number: μSxxxxMX78K0-ΔΔΔ

Remark xxxx and ΔΔΔ in the part number differ depending on the host machine and OS used.

μSxxxxMX78K0-ΔΔΔ

ΔΔΔ	Product Outline	Note
001	Evaluation object	Use for trial product.
xx	Object for mass-produced product	Use for mass-produced product.
S01	Source program	Can be purchased only when object for mass-produced product is purchased.

xxxx	Host Machine	OS	Supply Medium
AA13	PC-9800 Series	Windows Japanese version Notes 1, 2	3.5-inch 2HD FD
AB13	IBM PC/AT and compatibles	Windows Japanese version Notes 1, 2	3.5-inch 2HC FD
BB13		Windows English version Notes 1, 2	
3P16	HP9000 Series 700	HP-UX (Rel. 9.05)	DAT (DDS)
3K13	SPARCstation	SunOS (Rel. 4.1.4)	3.5-inch 2HC FD
3K15			1/4-inch CGMT
3R13	NEWS (RISC)	NEWS-OS (Rel. 6.1)	3.5-inch 2HC FD

- Notes**
1. DOS is also supported.
 2. WindowsNT is not supported.

APPENDIX C REGISTER INDEX

C.1 Register Index (In Alphabetical Order with Respect to Register Name)

[A]

A/D conversion result register (ADCR1) ... 150
A/D converter mode register (ADM1) ... 152
Analog input channel specification register (ADS1) ... 153
Asynchronous serial interface mode register (ASIM) ... 167, 171, 172
Asynchronous serial interface status register (ASIS) ... 169, 173

[B]

Baud rate generator control register (BRGC) ... 169, 174

[C]

Capture pulse control register (CRC0) ... 104
Capture register 00 (CR00) ... 102
Capture register 01 (CR01) ... 102
Capture register 02 (CR02) ... 102
Clock output selection register (CKS) ... 146
Compare control register 1 (MCMPC1) ... 217
Compare control register 2 (MCMPC2) ... 217
Compare control register 3 (MCMPC3) ... 217
Compare control register 4 (MCMPC4) ... 217
Compare register 10 (MCMP10) ... 215
Compare register 11 (MCMP11) ... 215
Compare register 20 (MCMP20) ... 215
Compare register 21 (MCMP21) ... 215
Compare register 30 (MCMP30) ... 215
Compare register 31 (MCMP31) ... 215
Compare register 40 (MCMP40) ... 215
Compare register 41 (MCMP41) ... 215

[D]

D/A converter mode register (DAM1) ... 163

[E]

EEPROM write control register (EEWC) ... 69
8-bit compare register 1 (CR1) ... 112
8-bit compare register 2 (CR2) ... 121
8-bit compare register 3 (CR3) ... 121
8-bit counter 1 (TM1) ... 112
8-bit counter 2 (TM2) ... 121
8-bit counter 3 (TM3) ... 121
8-bit timer mode control register 1 (TMC1) ... 114
8-bit timer mode control register 2 (TMC2) ... 123
8-bit timer mode control register 3 (TMC3) ... 123

External interrupt falling edge enable register (EGN) ... 231
 External interrupt rising edge enable register (EGP) ... 231

[I]

Interrupt mask flag register 0H (MK0H) ... 229
 Interrupt mask flag register 0L (MK0L) ... 229
 Interrupt mask flag register 1L (MK1L) ... 229
 Interrupt request flag register 0H (IF0H) ... 228
 Interrupt request flag register 0L (IF0L) ... 228
 Interrupt request flag register 1L (IF1L) ... 228

[L]

LCD display control register (LCDC) ... 193
 LCD display mode register (LCDM) ... 192
 LCD timer control register (LCDTM) ... 203

[M]

Memory size switching register (IMS) ... 258

[O]

Oscillation stabilization time select register (OSTS) ... 246
 Oscillator mode register (OSCM) ... 91

[P]

Port 0 (P0) ... 75
 Port 1 (P1) ... 76
 Port 2 (P2) ... 77
 Port 3 (P3) ... 78
 Port 4 (P4) ... 79
 Port 5 (P5) ... 80
 Port 6 (P6) ... 81
 Port 8 (P8) ... 82
 Port 9 (P9) ... 83
 Port mode control register (PMC) ... 217
 Port mode register 0 (PM0) ... 84
 Port mode register 2 (PM2) ... 84
 Port mode register 3 (PM3) ... 84
 Port mode register 4 (PM4) ... 84
 Port mode register 5 (PM5) ... 84
 Port mode register 6 (PM6) ... 84, 147
 Port mode register 8 (PM8) ... 84
 Port mode register 9 (PM9) ... 84
 Power-fail compare mode register (PFM) ... 154
 Power-fail compare threshold value register (PFT) ... 154
 Prescaler mode register (PRM0) ... 105, 232
 Priority specify flag register 0H (PR0H) ... 230
 Priority specify flag register 0L (PR0L) ... 230
 Priority specify flag register 1L (PR1L) ... 230
 Processor clock control register (PCC) ... 90
 Pull-up resistor option register (PU0) ... 87

[R]

Receive buffer register (RXB) ... 166

[S]

Serial I/O shift register (SIO) ... 184

Serial operation mode register (CSIM) ... 185, 186

16-bit timer mode control register (TMC0) ... 103

16-bit timer register (TM0) ... 102

Sound generator amplitude register (SGAM) ... 210

Sound generator buzzer control register (SGBR) ... 209

Sound generator control register (SGCR) ... 207

[T]

Timer clock select register 1 (TCL1) ... 113

Timer clock select register 2 (TCL2) ... 122

Timer clock select register 3 (TCL3) ... 122

Timer mode control register (MCNTC) ... 216

Transmit shift register (TXS) ... 166

[W]

Watch timer mode control register (WTM) ... 135

Watchdog timer clock select register (WDCS) ... 141

Watchdog timer mode register (WDTM) ... 142

C.2 Register Index (In Alphabetical Order with Respect to Register Symbol)**[A]**

- ADCR1 : A/D conversion result register ... 150
- ADM1 : A/D converter mode register ... 152
- ADS1 : Analog input channel specification register ... 153
- ASIM : Asynchronous serial interface mode register ... 167, 171, 172
- ASIS : Asynchronous serial interface status register ... 169, 173

[B]

- BRGC : Baud rate generator control register ... 169, 174

[C]

- CKS : Clock output selection register ... 146
- CR00 : Capture register 00 ... 102
- CR01 : Capture register 01 ... 102
- CR02 : Capture register 02 ... 102
- CR1 : 8-bit compare register 1 ... 112
- CR2 : 8-bit compare register 2 ... 121
- CR3 : 8-bit compare register 3 ... 121
- CRC0 : Capture pulse control register ... 104
- CSIM : Serial operation mode register ... 185, 186

[D]

- DAM1 : D/A converter mode register ... 163

[E]

- EEWC : EEPROM write control register ... 69
- EGN : External interrupt falling edge enable register ... 231
- EGP : External interrupt rising edge enable register ... 231

[I]

- IF0H : Interrupt request flag register 0H ... 228
- IF0L : Interrupt request flag register 0L ... 228
- IF1L : Interrupt request flag register 1L ... 228
- IMS : Memory size switching register ... 258

[L]

- LCDC : LCD display control register ... 193
- LCDM : LCD display mode register ... 192
- LCDTM : LCD timer control register ... 203

[M]

- MCMP10 : Compare register 10 ... 215
- MCMP11 : Compare register 11 ... 215
- MCMP20 : Compare register 20 ... 215
- MCMP21 : Compare register 21 ... 215
- MCMP30 : Compare register 30 ... 215
- MCMP31 : Compare register 31 ... 215

MCMP40 : Compare register 40 ... 215
 MCMP41 : Compare register 41 ... 215
 MCMPC1 : Compare control register 1 ... 217
 MCMPC2 : Compare control register 2 ... 217
 MCMPC3 : Compare control register 3 ... 217
 MCMPC4 : Compare control register 4 ... 217
 MCNTC : Timer mode control register ... 216
 MK0H : Interrupt mask flag register 0H ... 229
 MK0L : Interrupt mask flag register 0L ... 229
 MK1L : Interrupt mask flag register 1L ... 229

[O]

OSCM : Oscillator mode register ... 91
 OSTC : Oscillation stabilization time select register ... 246

[P]

P0 : Port 0 ... 75
 P1 : Port 1 ... 76
 P2 : Port 2 ... 77
 P3 : Port 3 ... 78
 P4 : Port 4 ... 79
 P5 : Port 5 ... 80
 P6 : Port 6 ... 81
 P8 : Port 8 ... 82
 P9 : Port 9 ... 83
 PCC : Processor clock control register ... 90
 PFM : Power-fail compare mode register ... 154
 PFT : Power-fail compare threshold value register ... 154
 PM0 : Port mode register 0 ... 84
 PM2 : Port mode register 2 ... 84
 PM3 : Port mode register 3 ... 84
 PM4 : Port mode register 4 ... 84
 PM5 : Port mode register 5 ... 84
 PM6 : Port mode register 6 ... 84, 147
 PM8 : Port mode register 8 ... 84
 PM9 : Port mode register 9 ... 84
 PMC : Port mode control register ... 217
 PROH : Priority specify flag register 0H ... 230
 PROL : Priority specify flag register 0L ... 230
 PR1L : Priority specify flag register 1L ... 230
 PRM0 : Prescaler mode register ... 105, 232
 PU0 : Pull-up resistor option register ... 87

[R]

RXB : Receive buffer register ... 166

[S]

SGAM : Sound generator amplitude register ... 210
 SGBR : Sound generator buzzer control register ... 209

SGCR : Sound generator control register ... 207
SIO : Serial I/O shift register ... 184

[T]

TCL1 : Timer clock select register 1 ... 113
TCL2 : Timer clock select register 2 ... 122
TCL3 : Timer clock select register 3 ... 122
TM0 : 16-bit timer register ... 102
TM1 : 8-bit counter 1 ... 112
TM2 : 8-bit counter 2 ... 121
TM3 : 8-bit counter 3 ... 121
TMC0 : 16-bit timer mode control register ... 103
TMC1 : 8-bit timer mode control register 1 ... 114
TMC2 : 8-bit timer mode control register 2 ... 123
TMC3 : 8-bit timer mode control register 3 ... 123
TXS : Transmit shift register ... 166

[W]

WDCS : Watchdog timer clock select register ... 141
WDTM : Watchdog timer mode register ... 142
WTM : Watch timer mode control register ... 135

APPENDIX D REVISION HISTORY

The revision history of this edition is listed below. "Chapter" indicates the chapter of the previous edition where the revision was made.

(1/2)

Edition	Revisions	Chapter
Second	Table 2-1. Pin Input/Output Circuit Types Correction of ports 8 and 9 input/output circuit types	CHAPTER 2 PIN FUNCTION
	Figure 2-1. I/O Circuits of Pins Change of type 17-A to type 17-G	
	Addition of oscillator mode register to Table 3-5. Special Function Register List	CHAPTER 3 CPU ARCHITECTURE
	4.1 EEPROM Functions Change of the number of rewrite frequency per 1 byte as follows: 10,000 times → 100,000 times	CHAPTER 4 EEPROM
	5.2.3 Port 2 <ul style="list-style-type: none"> • Correction of description • Correction of Figure 5-4. P20 to P27 Block Diagram 	CHAPTER 5 PORT FUNCTIONS
	5.2.4 Port 3 <ul style="list-style-type: none"> • Correction of description • Correction of Figure 5-5. P30 to P37 Block Diagram 	
	5.2.8 Port 8 <ul style="list-style-type: none"> • Correction of description • Addition of Figure 5-9. P81 Block Diagram • Correction of Figure 5-10. P82 to P87 Block Diagram 	
	5.2.9 Port 9 <ul style="list-style-type: none"> • Correction of description • Correction of Figure 5-11. P90 to P97 Block Diagram 	
	Table 5-3. Port Mode Register and Output Latch Settings when Using Alternate Functions <ul style="list-style-type: none"> • Change of P_{xx} setting values of P20 to P27 and P30 to P37 from 0 to x • Change of Note 2 	
	Addition of Note in Figure 5-13. Port Mode Register (PM2, PM3) Format	
	<ul style="list-style-type: none"> • Addition of oscillator mode register to Table 6-1. Clock Generator Configuration • Change of Figure 6-1. Clock Generator Block Diagram • Addition of (2) Oscillator mode register (OSCM) to 6.3 Clock Generator Control Register • Addition of explanation of oscillator mode register to 6.5 Operation of Clock Generator 	CHAPTER 6 CLOCK GENERATOR
	13.6 Cautions on Emulation Change of in-circuit emulator of (1) D/A converter mode register (DAM1) as follows: IE-78001-R-A → IE78K0-NS Addition of (2) A/D converter of IE-780974-NS-EM1	CHAPTER 13 A/D CONVERTER
	16.9 Cautions on Emulation Change of in-circuit emulator of (1) LCD timer control register (LCDTM) as follows: IE-78001-R-A → IE78K0-NS	CHAPTER 16 LCD CONTROLLER/DRIVER

Edition	Revisions	Chapter
Second	17.1 Sound Generator Function Correction of description on (1) Basic cycle output signal (with/without amplitude)	CHAPTER 17 SOUND GENERATOR
	18.2 Meter Controller/Driver Configuration Addition of Cautions to (1) Free running up counter (MCNT)	CHAPTER 18 METER CONTROLLER/DRIVER
	Table 20-1. HALT Mode Operating Status Correction of HALT mode operating status of A/D converter Operable → Operation stops	CHAPTER 20 STANDBY FUNCTION
	Addition of oscillator mode register to Table 21-1. Hardware Status after Reset	CHAPTER 21 RESET FUNCTION
	Change of Note in Table 22-1. Differences between μPD78F0974 and μPD780973(A)	CHAPTER 22 μPD78F0974
	<ul style="list-style-type: none"> • Support of in-circuit emulator IE-78K0-NS • Change in supported OS • Addition of A.4 Upgrading Former In-circuit Emulator for 78K/0 Series to IE-78001-R-A • Deletion of OS for IBM PC from previous edition • Deletion of Development Environment when Using IE-78000-R-A from previous edition 	APPENDIX A DEVELOPMENT TOOLS
	<ul style="list-style-type: none"> • Change in supported OS • Deletion of Fuzzy Inference Development Support System from previous edition 	APPENDIX B EMBEDDED SOFTWARE

Facsimile Message

Although NEC has taken all possible steps to ensure that the documentation supplied to our customers is complete, bug free and up-to-date, we readily accept that errors may occur. Despite all the care and precautions we've taken, you may encounter problems in the documentation. Please complete this form whenever you'd like to report errors or suggest improvements to us.

From:

Name

Company

Tel.

FAX

Address

Thank you for your kind support.

North America

NEC Electronics Inc.
Corporate Communications Dept.
Fax: 1-800-729-9288
1-408-588-6130

Hong Kong, Philippines, Oceania

NEC Electronics Hong Kong Ltd.
Fax: +852-2886-9022/9044

Asian Nations except Philippines

NEC Electronics Singapore Pte. Ltd.
Fax: +65-250-3583

Europe

NEC Electronics (Europe) GmbH
Technical Documentation Dept.
Fax: +49-211-6503-274

Korea

NEC Electronics Hong Kong Ltd.
Seoul Branch
Fax: 02-528-4411

Japan

NEC Semiconductor Technical Hotline
Fax: 044-548-7900

South America

NEC do Brasil S.A.
Fax: +55-11-6465-6829

Taiwan

NEC Electronics Taiwan Ltd.
Fax: 02-719-5951

I would like to report the following error/make the following suggestion:

Document title: _____

Document number: _____ Page number: _____

If possible, please fax the referenced page or drawing.

Document Rating	Excellent	Good	Acceptable	Poor
Clarity	<input type="checkbox"/>	<input type="checkbox"/>	<input type="checkbox"/>	<input type="checkbox"/>
Technical Accuracy	<input type="checkbox"/>	<input type="checkbox"/>	<input type="checkbox"/>	<input type="checkbox"/>
Organization	<input type="checkbox"/>	<input type="checkbox"/>	<input type="checkbox"/>	<input type="checkbox"/>